

FEATURES

Single-/dual-supply operation: 1.6 V to 36 V, ± 0.8 V to ± 18 V
True single-supply operation; input and output voltage
Input/output ranges include ground
Low supply current (per amplifier), 20 μ A maximum
High output drive, 5 mA minimum
Low input offset voltage, 200 μ V typical
High open-loop gain, 400 V/mV minimum
Outstanding PSRR, 5.6 μ V/V maximum
Industry standard 8-lead dual pinout

GENERAL DESCRIPTION

The OP290 is a high performance micropower dual op amp that operates from a single supply of 1.6 V to 36 V or from dual supplies of ± 0.8 V to ± 18 V. Input voltage range includes the negative rail allowing the OP290 to accommodate input signals down to ground in single-supply operation. The OP290 output swing also includes ground when operating from a single supply, enabling zero-in, zero-out operation.

The OP290 draws less than 20 μ A of quiescent supply current per amplifier, while being able to deliver over 5 mA of output current to a load. Input offset voltage is below 200 μ V, eliminating the need for external nulling. Gain exceeds 700,000 and

common-mode rejection is better than 100 dB. The power supply rejection ratio of under 5.6 μ V/V minimizes offset voltage changes experienced in battery-powered systems. The low offset voltage and high gain offered by the OP290 bring precision performance to micropower applications. The minimal performance and current requirements of the OP290 suit it for battery- and solar-powered applications, such as portable instruments, remote sensors, and satellites. For a single op amp, see the [OP90](#); for a quad, see the [OP490](#).

PIN CONNECTIONS

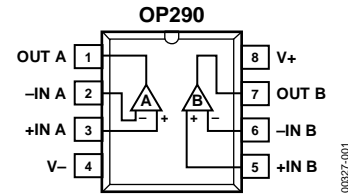

Figure 1. PDIP (P-Suffix)

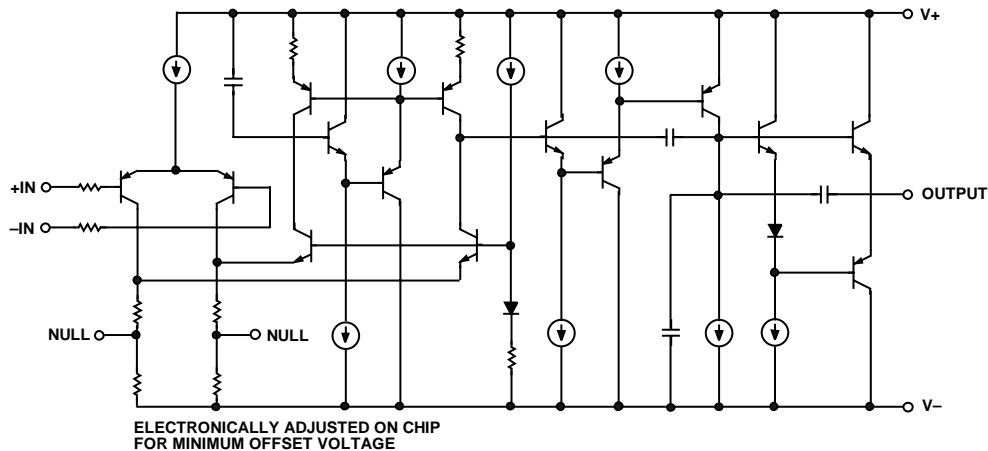

Figure 2. Simplified Schematic (One of Two Amplifiers Is Shown)

Rev. C

Information furnished by Analog Devices is believed to be accurate and reliable. However, no responsibility is assumed by Analog Devices for its use, nor for any infringements of patents or other rights of third parties that may result from its use. Specifications subject to change without notice. No license is granted by implication or otherwise under any patent or patent rights of Analog Devices. Trademarks and registered trademarks are the property of their respective owners.

OP290* Product Page Quick Links

Last Content Update: 11/01/2016

[Comparable Parts](#)

View a parametric search of comparable parts

[Documentation](#)

Application Notes

- AN-349: Keys to Longer Life for CMOS
- AN-649: Using the Analog Devices Active Filter Design Tool

Data Sheet

- OP290: Dual Precision, Low Power, Micropower Dual Operational Amplifier Data Sheet
- OP290: Military Data Sheet

[Tools and Simulations](#)

- OP290 SPICE Macro-Model

[Design Resources](#)

- OP290 Material Declaration
- PCN-PDN Information
- Quality And Reliability
- Symbols and Footprints

[Discussions](#)

View all OP290 EngineerZone Discussions

[Sample and Buy](#)

Visit the product page to see pricing options

[Technical Support](#)

Submit a technical question or find your regional support number

TABLE OF CONTENTS

Features 1
 Pin Connections 1
 General Description 1
 Revision History 2
 Specifications..... 3
 Electrical Characteristics 3
 Absolute Maximum Ratings..... 5
 ESD Caution..... 5
 Typical Performance Characteristics 6
 Theory of Operation 9

Battery-Powered Applications9
 Input Voltage Protection9
 Single-Supply Output Voltage Range.....9
 Applications Information 10
 Temperature to 4 mA to 20 mA Transmitter..... 10
 Variable Slew Rate Filter 11
 Low Overhead Voltage Reference 11
 Outline Dimensions 12
 Ordering Guide 12

REVISION HISTORY

4/09—Rev. B to Rev. C

Updated Format Universal
 Changes to Features Section and Figure 2..... 1
 Changes to Input Voltage Range, $V_s = \pm 5$ V Parameter,
 Table 1 3
 Changes to Figure 7 and Figure 8..... 6
 Deleted Figure 2; Renumbered Sequentially..... 7
 Changes to Figure 9..... 7
 Changed Applications Information Heading to Theory of
 Operation..... 9
 Changes to Figure 19..... 9
 Changed Applications Heading to Applications Information.. 10
 Changes to Temperature to 4 mA to 20 mA Transmitter Section,
 Figure 20, and Table 5 10
 Changes to Figure 21 and Figure 22..... 11
 Updated Outline Dimensions 12
 Changes to Ordering Guide 12

12/03—Rev. A to Rev. B

Deleted OP290E and OP290F..... Universal
 Replaced Pin Connections with PDIP..... 1
 Deleted Electrical Characteristics 3
 Changes to Absolute Maximum Ratings..... 4
 Changes to Ordering Guide 4
 Changes to TPC 6..... 5
 Change to Single Supply Output Voltage Range 7
 Changes to Figure 5..... 8
 Changes to Figure 6..... 9
 Change to Low Overhead Voltage Reference 9
 Updated Outline Dimensions 10

1/02—Rev. 0 to Rev. A

Edits to Ordering Information 1
 Edits to Pin Connections..... 1
 Edits to Absolute Maximum Ratings..... 2
 Edits to Package Type 2
 Edits to Wafer Test Limits 5
 Edits to Dice Characteristics..... 5

SPECIFICATIONS

ELECTRICAL CHARACTERISTICS

$V_s = \pm 1.5 \text{ V}$ to $\pm 15 \text{ V}$, $T_A = 25^\circ\text{C}$, unless otherwise noted.

Table 1.

Parameter	Symbol	Conditions	OP290G			Unit
			Min	Typ	Max	
INPUT OFFSET VOLTAGE	V_{OS}			125	500	μV
INPUT OFFSET CURRENT	I_{OS}	$V_{CM} = 0 \text{ V}$		0.1	5	nA
INPUT BIAS CURRENT	I_B	$V_{CM} = 0 \text{ V}$		4.0	25	nA
LARGE-SIGNAL VOLTAGE GAIN	A_{VO}	$V_s = \pm 15 \text{ V}, V_o = \pm 10 \text{ V}$		400	600	V/mV
		$R_L = 100 \text{ k}\Omega$		200	400	V/mV
		$R_L = 10 \text{ k}\Omega$		100	200	V/mV
		$R_L = 2 \text{ k}\Omega$		100	250	V/mV
		$V_+ = 5 \text{ V}, V_- = 0 \text{ V}, 1 \text{ V} < V_o < 4 \text{ V}$		70	140	V/mV
INPUT VOLTAGE RANGE ¹	IVR	$V_+ = 5 \text{ V}, V_- = 0 \text{ V}$	0/4			V
		$V_s = \pm 5 \text{ V}$	-5/+3.5			V
OUTPUT VOLTAGE SWING	V_o V_{OH}, V_{OL}	$V_s = \pm 5 \text{ V}$	± 13.5	± 14.2		V
		$R_L = 10 \text{ k}\Omega$	± 10.5	± 11.5		V
		$R_L = 2 \text{ k}\Omega$	4.0	4.2		V
		$V_+ = 5 \text{ V}, V_- = 0 \text{ V}$	10	50		μV
COMMON-MODE REJECTION	CMR	$V_+ = 5 \text{ V}, V_- = 0 \text{ V}, 0 \text{ V} < V_{CM} < 4 \text{ V}$	80	100		dB
		$V_s = \pm 15 \text{ V}, -15 \text{ V} < V_{CM} < +13.5 \text{ V}$	90	120		dB
POWER SUPPLY REJECTION RATIO	PSRR		3.2	10		$\mu\text{V}/\text{V}$
SUPPLY CURRENT (ALL AMPLIFIERS)	I_{SY}	$V_s = \pm 1.5 \text{ V}$		19	30	μA
		$V_s = \pm 15 \text{ V}$		25	40	μA
CAPACITIVE LOAD STABILITY		$A_v = +1$, no oscillations		650		pF
INPUT NOISE VOLTAGE ¹	e_n p-p	$f_o = 0.1 \text{ Hz to } 10 \text{ Hz}, V_s = \pm 15 \text{ V}$		3		$\mu\text{V p-p}$
INPUT RESISTANCE DIFFERENTIAL MODE	R_{IN}	$V_s = \pm 15 \text{ V}$		30		M Ω
INPUT RESISTANCE COMMON MODE	R_{INCM}	$V_s = \pm 15 \text{ V}$		20		G Ω
SLEW RATE	SR	$A_v = +1, V_s = \pm 15 \text{ V}$	5	12		V/ms
GAIN BANDWIDTH PRODUCT	GBWP	$V_s = \pm 15 \text{ V}$		20		kHz
CHANNEL SEPARATION ²	CS	$f_o = 10 \text{ Hz}, V_o = 20 \text{ V p-p}, V_s = \pm 15 \text{ V}$	120	150		dB

¹ Guaranteed by CMR test.

² Guaranteed but not 100% tested.

OP290

$V_S = \pm 1.5 \text{ V}$ to $\pm 15 \text{ V}$, $-40^\circ\text{C} \leq T_A \leq +85^\circ\text{C}$, unless otherwise noted.

Table 2.

Parameter	Symbol	Conditions	OP290G			Unit	
			Min	Typ	Max		
INPUT OFFSET VOLTAGE	V_{OS}			200	750	μV	
AVERAGE INPUT OFFSET VOLTAGE DRIFT	TCV_{OS}	$V_S = \pm 15 \text{ V}$		1.2		$\mu\text{V}/^\circ\text{C}$	
INPUT OFFSET CURRENT	I_{OS}	$V_{CM} = 0 \text{ V}$		0.1	7	nA	
INPUT BIAS CURRENT	I_B	$V_{CM} = 0 \text{ V}$		4.2	25	nA	
LARGE-SIGNAL VOLTAGE GAIN	A_{VO}	$V_S = \pm 5 \text{ V}, V_O = \pm 0 \text{ V}$	300	600		V/mV	
		$R_L = 100 \text{ k}\Omega$	150	250		V/mV	
		$R_L = 10 \text{ k}\Omega$	75	125		V/mV	
		$R_L = 2 \text{ k}\Omega$					
		$V_+ = 5 \text{ V}, V_- = 0 \text{ V}, 1 \text{ V} < V_O < 4 \text{ V}$	80	160		V/mV	
		$R_L = 10 \text{ k}\Omega$	40	90		V/mV	
INPUT VOLTAGE RANGE ¹	IVR	$V_+ = 5 \text{ V}, V_- = 0 \text{ V}$	0/3.5			V	
		$V_S = +15 \text{ V}$	-15/+13.5			V	
OUTPUT VOLTAGE SWING	V_O	$V_S = \pm 15 \text{ V}$	± 13	± 14		V	
		$R_L = 10 \text{ k}\Omega$	± 10	± 11		V	
	$R_L = 2 \text{ k}\Omega$	3.9	4.1		V		
	V_{OH}	$V_+ = 5 \text{ V}, V_- = 0 \text{ V}, R_L = 2 \text{ k}\Omega$				V	
	V_{OL}	$V_+ = 5 \text{ V}, V_- = 0 \text{ V}, R_L = 10 \text{ k}\Omega$		10	100	μV	
COMMON-MODE REJECTION	CMR	$V_+ = 5 \text{ V}, V_- = 0 \text{ V}, 0 \text{ V} < V_{CM} < 3.5 \text{ V}$	80	100		dB	
		$V_S = \pm 15 \text{ V}, -15 \text{ V} < V_{CM} < 13.5 \text{ V}$	90	110		dB	
POWER SUPPLY REJECTION RATIO	PSRR			5.6	15	$\mu\text{V}/\text{V}$	
SUPPLY CURRENT (ALL AMPLIFIERS)	I_{SY}	$V_S = \pm 1.5 \text{ V}$		24	50	μA	
		$V_S = \pm 15 \text{ V}$		31	60	μA	

¹ Guaranteed by CMR test.

ABSOLUTE MAXIMUM RATINGS

Table 3.

Parameter ¹	Rating
Supply Voltage	±18 V
Differential Input Voltage	[(V-) - 20 V] to [(V+) + 20 V]
Common-Mode Input Voltage	[(V-) - 20 V] to [(V+) + 20 V]
Output Short-Circuit Duration	Indefinite
Storage Temperature Range	-65°C to +150°C
Operating Temperature Range	-40°C to +85°C
Junction Temperature Range (T _J)	-65°C to +150°C
Lead Temperature (Soldering, 60 sec)	300°C

¹ Absolute maximum ratings applies to packaged part.

Stresses above those listed under Absolute Maximum Ratings may cause permanent damage to the device. This is a stress rating only; functional operation of the device at these or any other conditions above those indicated in the operational section of this specification is not implied. Exposure to absolute maximum rating conditions for extended periods may affect device reliability.

Table 4.

Package Type	θ_{JA} ¹	θ_{JC}	Unit
8-Lead Plastic DIP (P)	96	37	°C/W

¹ θ_{JA} is specified for worst-case mounting conditions, that is, θ_{JA} is specified for device in socket for PDIP package.

ESD CAUTION



ESD (electrostatic discharge) sensitive device. Charged devices and circuit boards can discharge without detection. Although this product features patented or proprietary protection circuitry, damage may occur on devices subjected to high energy ESD. Therefore, proper ESD precautions should be taken to avoid performance degradation or loss of functionality.

TYPICAL PERFORMANCE CHARACTERISTICS

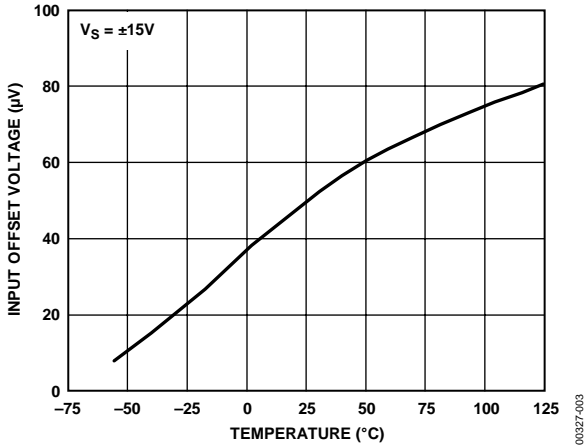

Figure 3. Input Offset Voltage vs. Temperature

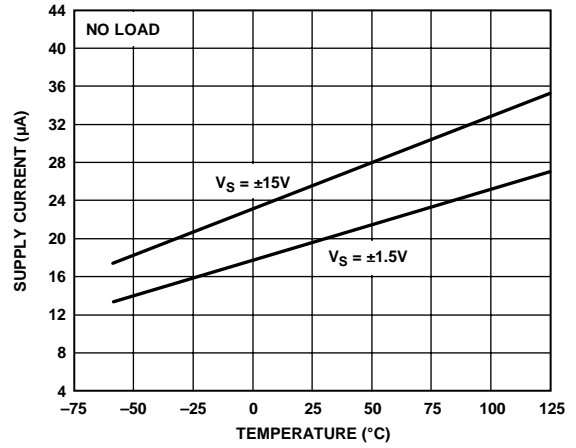

Figure 6. Supply Current vs. Temperature

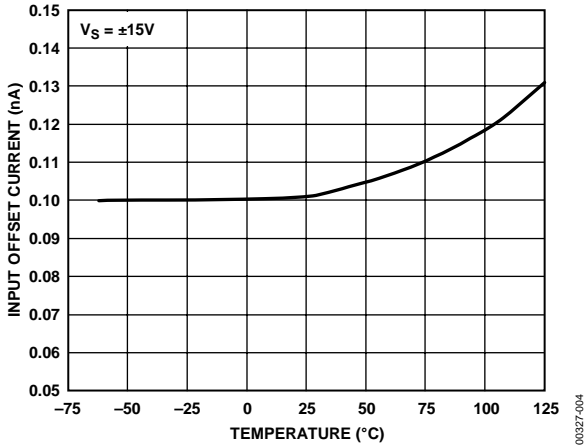

Figure 4. Input Offset Current vs. Temperature

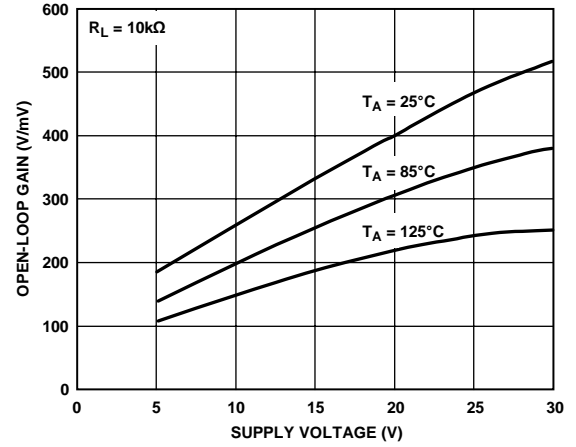

Figure 7. Open-Loop Gain vs. Supply Voltage

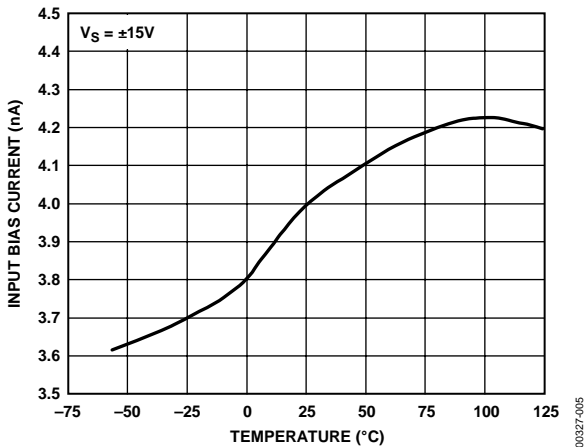

Figure 5. Input Bias Current vs. Temperature

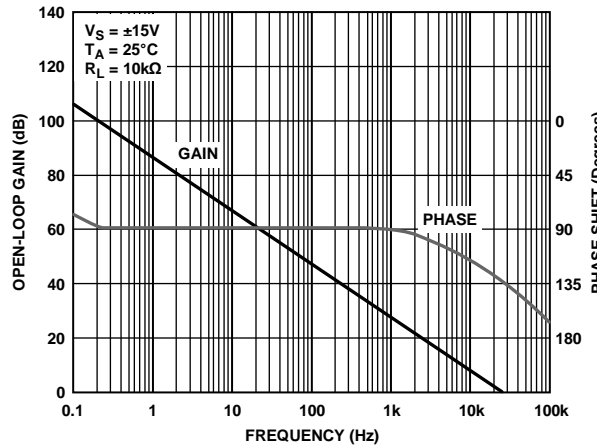

Figure 8. Open-Loop Gain and Phase Shift vs. Frequency

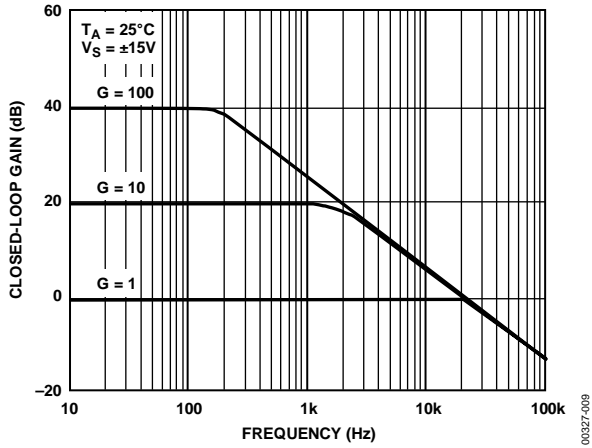

Figure 9. Closed-Loop Gain vs. Frequency

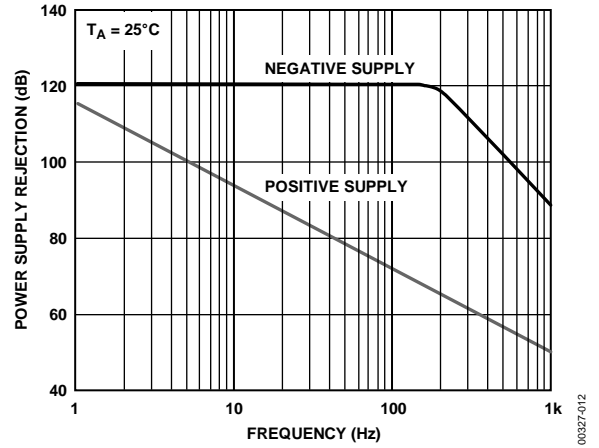

Figure 12. Power Supply Rejection vs. Frequency

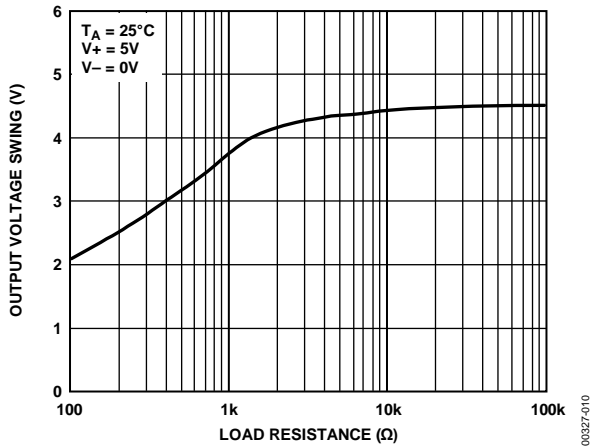

Figure 10. Output Voltage Swing vs. Load Resistance

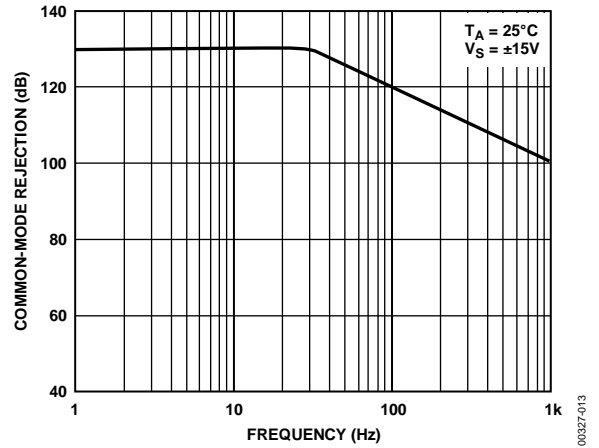

Figure 13. Common-Mode Rejection vs. Frequency

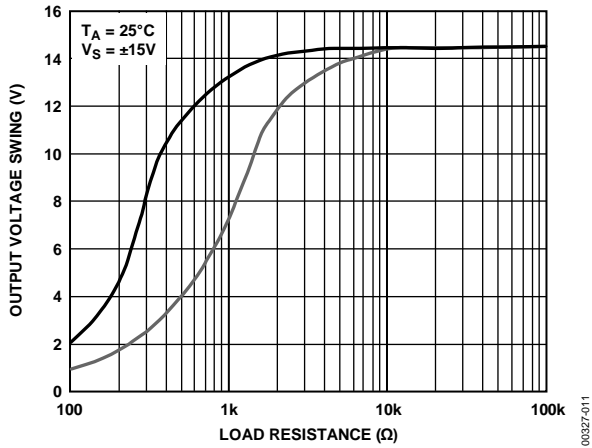

Figure 11. Output Voltage Swing vs. Load Resistance

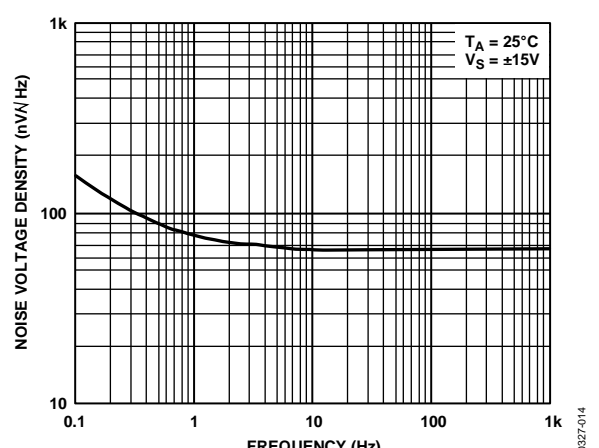

Figure 14. Noise Voltage Density vs. Frequency

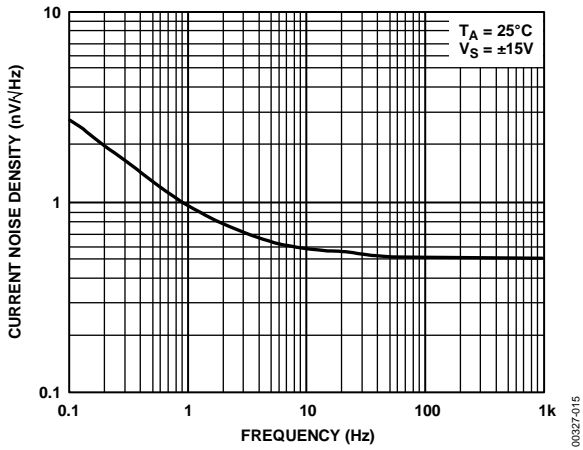

Figure 15. Current Noise Density vs. Frequency

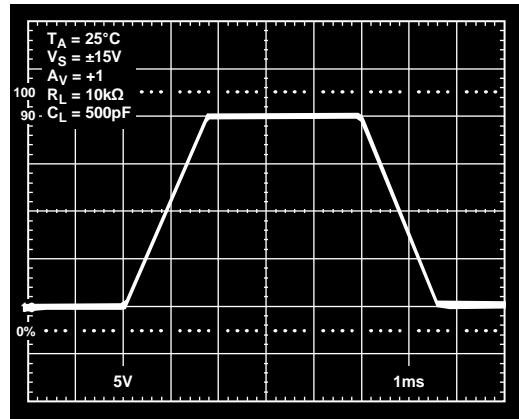

Figure 17. Large-Signal Transient Response

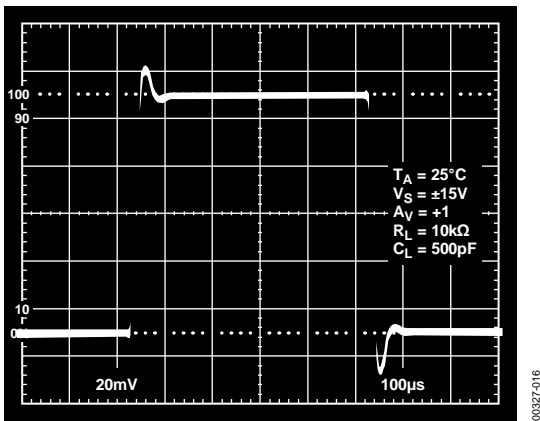

Figure 16. Small-Signal Transient Response

THEORY OF OPERATION

BATTERY-POWERED APPLICATIONS

The OP290 can be operated on a minimum supply voltage of 1.6 V, or with dual supplies of ± 0.8 V, and draws only 19 μ A of supply current. In many battery-powered circuits, the OP290 can be continuously operated for thousands of hours before requiring battery replacement, reducing equipment downtime and operating cost.

High performance portable equipment and instruments frequently use lithium cells because of their long shelf-life, light weight, and high energy density relative to older primary cells. Most lithium cells have a nominal output voltage of 3 V and are noted for a flat discharge characteristic. The low supply voltage requirement of the OP290, combined with the flat discharge characteristic of the lithium cell, indicates that the OP290 can be operated over the entire useful life of the cell. Figure 18 shows the typical discharge characteristic of a 1 Ah lithium cell powering an OP290, with each amplifier, in turn, driving full output swing into a 100 k Ω load.

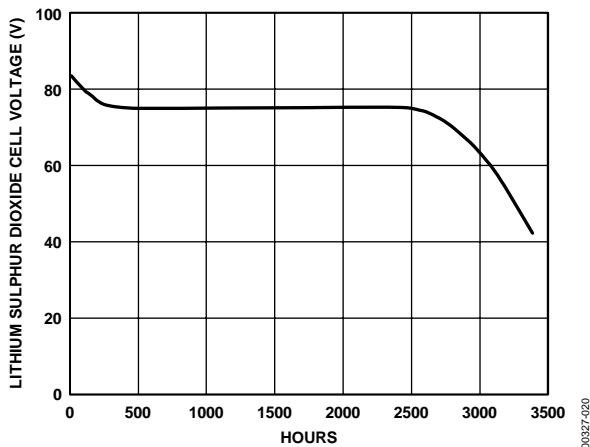

Figure 18. Lithium Sulphur Dioxide Cell Discharge Characteristic with OP290 and 100 k Ω Load

INPUT VOLTAGE PROTECTION

The OP290 uses a PNP input stage with protection resistors in series with the inverting and noninverting inputs. The high breakdown of the PNP transistors coupled with the protection resistors provide a large amount of input protection, allowing the inputs to be taken 20 V beyond either supply without damaging the amplifier.

SINGLE-SUPPLY OUTPUT VOLTAGE RANGE

In single-supply operation, the OP290 input and output ranges include ground. This allows true zero-in, zero-out operation. The output stage provides an active pull-down to around 0.8 V above ground. Below this level, a load resistance of up to 1 M Ω to ground is required to pull the output down to zero.

In the region from ground to 0.8 V, the OP290 has voltage gain equal to the specification in Table 1. Output current source capability is maintained over the entire voltage range including ground.

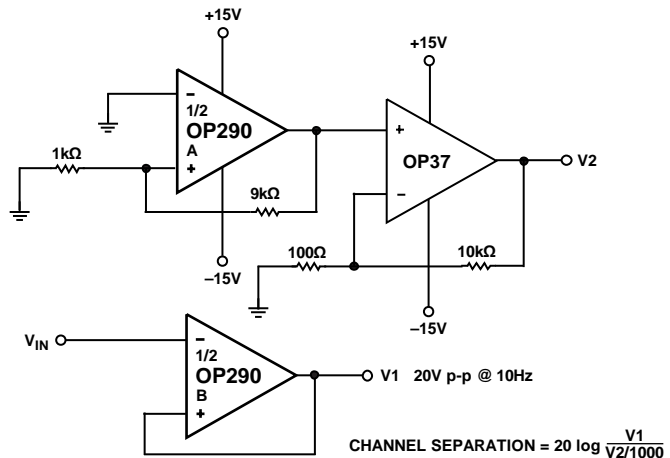

Figure 19. Channel Separation Test Circuit

APPLICATIONS INFORMATION

TEMPERATURE TO 4 mA TO 20 mA TRANSMITTER

A simple temperature to 4 mA to 20 mA transmitter is shown in Figure 20. After calibration, the transmitter is accurate to $\pm 0.5^\circ\text{C}$ over the -50°C to $+150^\circ\text{C}$ temperature range. The transmitter operates from 8 V to 40 V with supply rejection better than 3 ppm/V. One half of the OP290 is used to buffer the V_{TEMP} pin while the other half regulates the output current to satisfy the current summation at its noninverting input.

$$I_{OUT} = \frac{V_{TEMP}(R6 + R7)}{R2 \times R10} - V_{SET} \left(\frac{R2 \times R6 \times R7}{R2 \times R10} \right) \quad (1)$$

The change in output current with temperature is the derivative of the following transfer function:

$$\frac{\Delta I_{OUT}}{\Delta T} = \frac{\Delta V_{TEMP}}{\Delta T} \frac{(R6 + R7)}{R2 \times R10} \quad (2)$$

From Equation 1 and Equation 2, it can be seen that if the span trim is adjusted before the zero trim, the two trims are not interactive, which greatly simplifies the calibration procedure.

Calibration of the transmitter is simple. First, the slope of the output current vs. temperature is calibrated by adjusting the span trim, R7. A couple of iterations may be required to ensure that the slope is correct.

Once the span trim has been completed, the zero trim can be made. Remember that adjusting the offset trim does not affect the gain. The offset trim can be set at any known temperature by adjusting R5 until the output current equals

$$I_{OUT} = \left(\frac{\Delta I_{FS}}{\Delta T_{OPERATING}} \right) (T_A - T_{MIN}) + 4 \text{ mA}$$

Table 5 shows the values of R6 that are required for various temperature ranges.

Table 5.

Temperature Range	R6 (k Ω)
0°C to +70°C	10
-40°C to +85°C	6.2
-50°C to +150°C	3

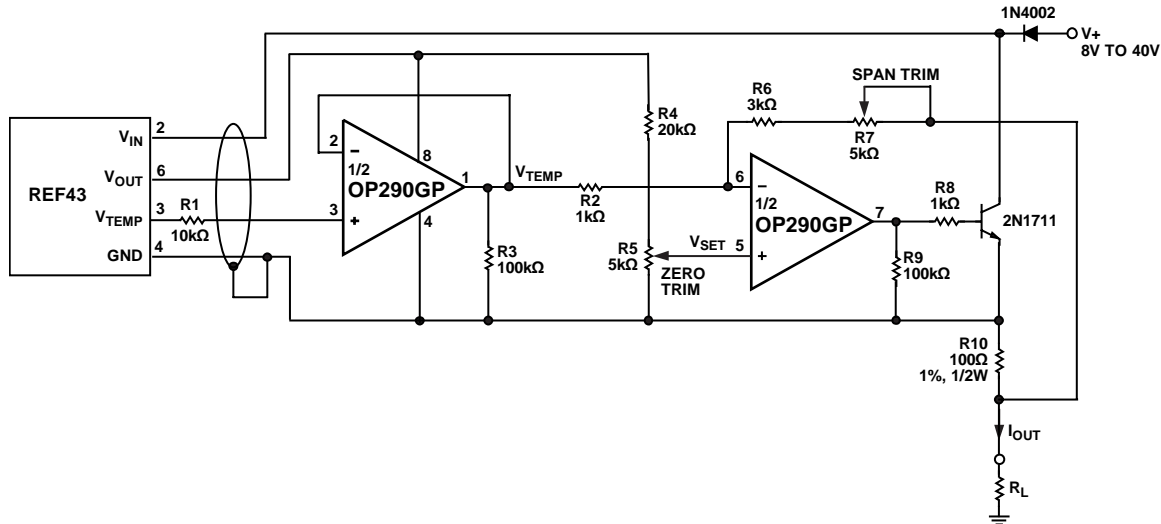

Figure 20. Temperature to 4 mA to 20 mA Transmitter

00327-021

VARIABLE SLEW RATE FILTER

The circuit shown in Figure 21 can be used to remove pulse noise from an input signal without limiting the response rate to a genuine signal. The nonlinear filter has use in applications where the input signal of interest is known to have physical limitations. An example of this is a transducer output where a change of temperature or pressure cannot exceed a certain rate due to physical limitations of the environment. The filter consists of a comparator that drives an integrator. The comparator compares the input voltage to the output voltage and forces the integrator output to equal the input voltage. A1 acts as a comparator with its output high or low. Diode D1 and Diode D2 clamp the voltage across R3, forcing a constant current to flow in or out of C2. R3, C2, and A2 form an integrator with the output of A2 slewing at a maximum rate of

$$\text{Maximum slew rate} = \frac{V_D}{R3 \times C2} \approx \frac{0.6 \text{ V}}{R3 \times C2}$$

For an input voltage slewing at a rate under this maximum slew rate, the output simply follows the input with A1 operating in its linear region.

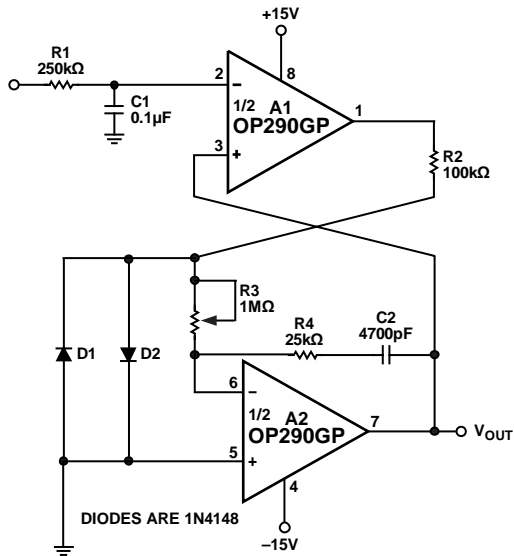

Figure 21. Variable Slew Rate Filter

00327-022

LOW OVERHEAD VOLTAGE REFERENCE

Figure 22 shows a voltage reference that requires only 0.1 V of overhead voltage. As shown, the reference provides a stable 4.5 V output with a 4.6 V to 36 V supply. Output voltage drift is only 12 ppm/°C. Line regulation of the reference is under 5 μV/V with load regulation better than 10 μV/mA with up to 50 mA of output current.

The REF43 provides a stable 2.5 V that is multiplied by the OP290. The PNP output transistor enables the output voltage to approach the supply voltage.

Resistor R1 and Resistor R2 determine the output voltage.

$$V_{OUT} = 2.5 \text{ V} \left(1 + \frac{R2}{R1} \right)$$

The 200 Ω variable resistor is used to trim the output voltage. For the lowest temperature drift, parallel resistors can be used in place of the variable resistor and taken out of the circuit as required to adjust the output voltage.

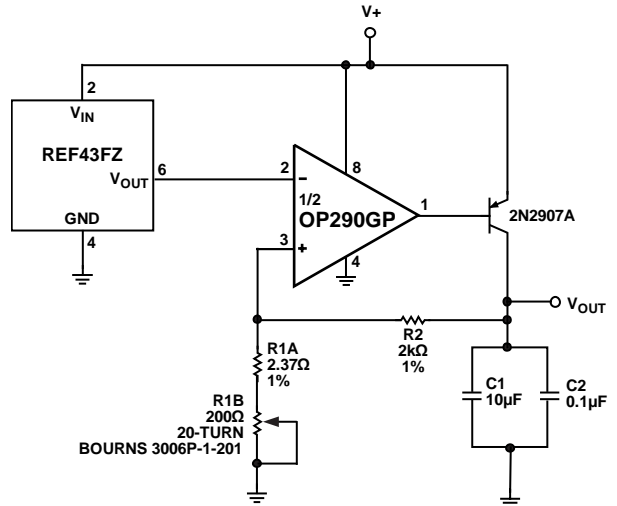
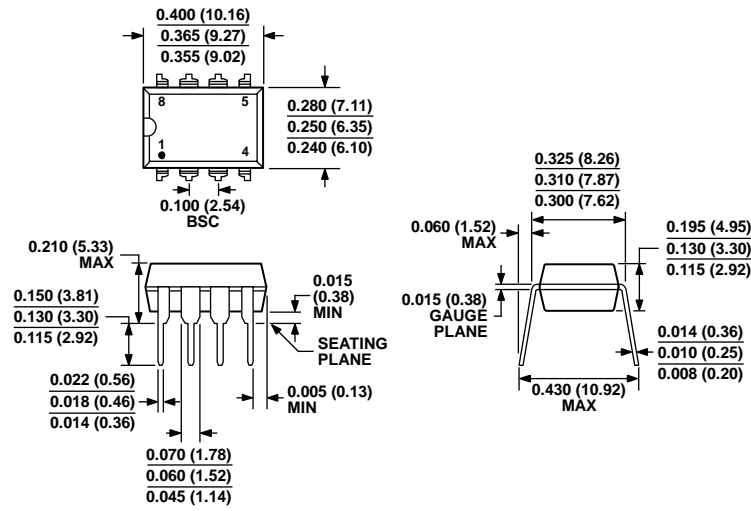

Figure 22. Low Overhead Voltage Reference

00327-023

OUTLINE DIMENSIONS



COMPLIANT TO JEDEC STANDARDS MS-001
 CONTROLLING DIMENSIONS ARE IN INCHES; MILLIMETER DIMENSIONS
 (IN PARENTHESES) ARE ROUNDED-OFF INCH EQUIVALENTS FOR
 REFERENCE ONLY AND ARE NOT APPROPRIATE FOR USE IN DESIGN.
 CORNER LEADS MAY BE CONFIGURED AS WHOLE OR HALF LEADS.

Figure 23. 8-Lead Plastic Dual In-Line Package [PDIP]
 [P-Suffix]
 (N-8)

Dimensions shown in inches and (millimeters)

070606-A

ORDERING GUIDE

Model	T _A = 25°C V _{OS} Max (mV)	Temperature Range	Package Description	Package Option
OP290GP	500	-40°C to +85°C	8-Lead Plastic PDIP	P-Suffix (N-8)
OP290GPZ ¹	500	-40°C to +85°C	8-Lead Plastic PDIP	P-Suffix (N-8)

¹ Z = RoHS Compliant Part.