

Wrist Strap and Footwear Tester Installation, Operation and Maintenance



Figure 1. Wrist Strap and Footwear Tester.

Description

The SCS 740 Wrist Strap and Footwear Tester meets ANSI/ESD S20.20 per ESD TR53 Compliance Verification testing of personnel grounding devices. The SCS 740 Wrist Strap and Footwear Testers are electronic test instruments that are easy to operate and designed to be wall-mounted. An AC/DC transformer is supplied. The Wrist Strap and Footwear Tester switches off automatically after non-use for approximately 30 minutes.

The unit consists of two measurement circuits with an open circuit test voltage of 14V for wrist strap and shoe test applications. For wrist strap and footwear testing, a minimum threshold resistance of 750 kilohm is set internally. The desired maximum allowable resistance level can be selected separately for each measurement. If the resistance of the tested wrist strap or footwear is within the selected range, the green "o.k."- LED will illuminate. The red ">" - LED alerts the operator that the resistance of the tested device is under 750 kilohm. The red ">"- LED indicates that the selected maximum resistance is exceeded.

The Wrist Strap and Footwear Tester can be connected to external devices such as computers (for data recording), electrical door opening systems, or other logic driven components.

The Wrist Strap and Footwear Tester is available in two models:

Item	Description
740	Wrist Strap and Footwear Tester, North America
740E	Wrist Strap and Footwear Tester, Europe

Features and Components

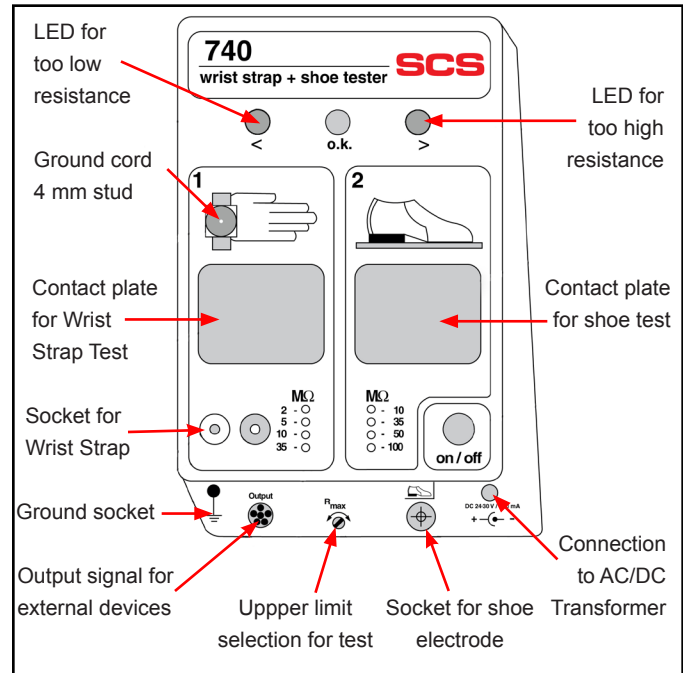

Figure 2. Wrist Strap and Footwear Tester features and components.

SCS offers the following accessories for the Wrist Strap and Footwear Tester:

Item	Description
741	Single Foot Plate, for 740 Tester
741D	Dual Foot Plate, for 740E Tester
741DC	Foot Plate Cable, for 741D Foot Plate
740P	Power Adapter, North America Plug
740E-X	Power Adapter, Europe Plug

Packaging

- 1 Wrist Strap and Footwear Tester
- 1 Wall Mounting Kit (Dual Lock Fastening System)
- 1 Power Adapter

Installation

Connecting the 741 and 741D Stainless Steel Foot Plates

1. Connect the enclosed cord with the snap fastener end to the stud of the electrode.
2. Connect the plug to the appropriate socket of the 740/740E Wrist Strap and Footwear Tester.
3. Switch the 740/740E unit on. Continue with Wrist Strap and Footwear operating instructions.

Operation

Connect the Power Adapter (24-30VDC, 150mA) to the Wrist Strap and Footwear Tester.

Note: If you notice a delay in the response time of the LED illumination please connect the ground cord supplied to the ground socket of the Wrist Strap and Footwear Tester. Ensure a proper earth ground connection.



Switch the unit on. All LEDs will flash for approximately 1 second to check their function. Select the desired upper maximum resistance level for both the wrist strap and shoe test by using a small screw driver.



The foot plate must be connected if footwear testing is required.

Wall Mounting

The enclosed Dual Lock Fastening Discs must be screwed to the wall using the attached template approximately 1.5 m (5 feet) above the floor. Drill three holes of 5 mm (0.2 in.) Diameter at marked locations. Make sure the area on the Wrist Strap and Footwear Tester 740 in which the Dual Lock Fastening Strips are placed is free of dust and dirt. Attach the Dual Lock Fastening Strips to the rear of the Wrist Strap and Footwear Tester to the bottom and top in parallel; see drawing for locations.

For securing on the wall, press the Wrist Strap and Footwear Tester firmly against the discs. For removal of the Wrist Strap and Footwear Tester, lift the top corners with both hands.

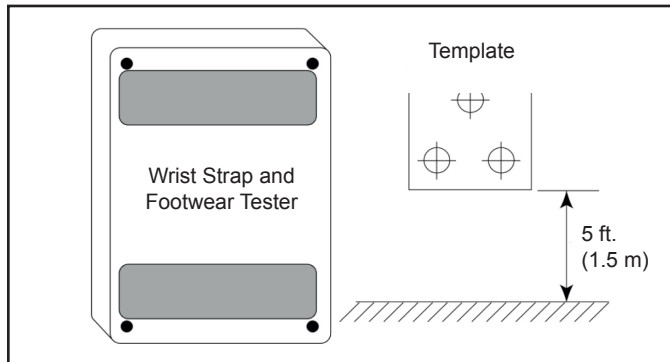

Figure 3. Using the Dual Lock Fastening Discs for mounting.

Wrist Strap Test

Put the wristband on with ground cord attached and insert the ground cord into the wrist strap plug-in jack. Depress the metal contact plate and hold it. One of the indicator-LEDs will illuminate.

An illuminated green LED indicates that the wrist strap performs within the resistance range of 750 kilohm to the upper selected value of 2, 5, 10 or 35 megohm. If a red "<"-LED is on, the current limiting resistor in the ground cord is bypassed and the cord has to be replaced. The red ">"-LED indicates that the selected resistance range is exceeded. Check to see if the high resistance is in the cord, the wristband or in the contact between wristband and the operator's skin. To check the resistance of the ground cord, leave the plug end of the ground cord attached to the tester and disconnect the snap end from the wristband. Connect ground cord snap to the stud in the hand symbol or press it onto the contact plate and depress the plate until one of the LEDs is illuminated.

If the green LED illuminates now, the ground cord can be used.

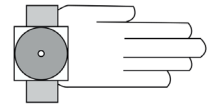

If the red ">"-LED is lit, replace the ground cord.

In some cases, high contact resistance between the skin and wristband will cause the tester to show a red ">"-LED condition. This resistance may be caused by dry skin or the presence of hair in the wrist area. The use of a skin lotion is recommended to solve this problem.

If a red ">"-LED condition still exists, replace the wristband. Or the presence of hair in the wrist area. The use of a skin lotion is recommended to solve this problem.

If a red ">"-LED condition still exists, replace the wristband.

Shoe Test

The Shoe Electrode must be connected to the Wrist Strap and Footwear Tester shoe jack.



Switch the Wrist Strap and Footwear Tester on. Stand on the applied shoe electrode. If you are using shoe straps with a 1 megohm resistor on both feet to be tested with the Shoe Electrode, you have to test the straps one after the other, to avoid a red "too low" - indication. Care must be taken not to put the non-tested foot on ESD - protective flooring to avoid a bypass to ground. Press the metal contact plate for shoe test until one of the indicator - LEDs lights up.

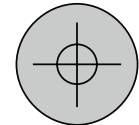

The green LED indicates that the resistance of the person through the footwear is in the range between 750 kilohm and the desired upper maximum level (10, 35, 50 or 100 megohm).

Data Output Connector

If you are going to use the data output connector, you must follow a test sequence. Test the wrist strap first and then the shoe. **If this sequence is not strictly kept, the output at the pins described in Figure 6 will be incorrect.**

The Wrist Strap and Footwear Tester will provide digital signals (high/low) while testing the personnel grounding devices. These digital signals can be used for data recording (Figure 4) and authorization control equipment such as electrical door opening systems (Figure 5). The output of the Wrist Strap and Footwear Tester will give you permanently + 5V at pin 3 and DC-return at pin 6. The remaining pins 1, 2, 4 and 5 (open collector) will be high (max. +30V / 20mA have to be provided externally) or low (DC-return) while pressing on the contact plates either for wrist strap or shoe tests. The chart in Figure 6 shows all of the possible test results and the corresponding output levels.

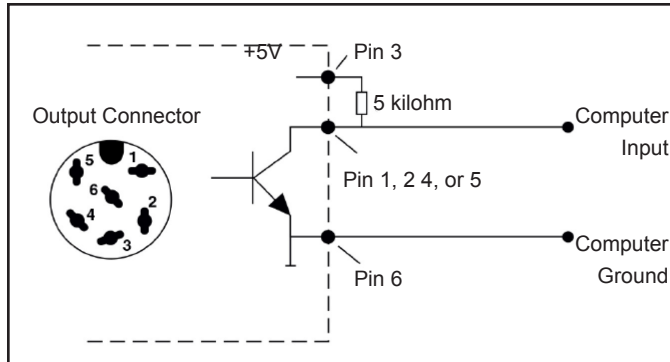

Figure 4. Output connection for use with a computer.

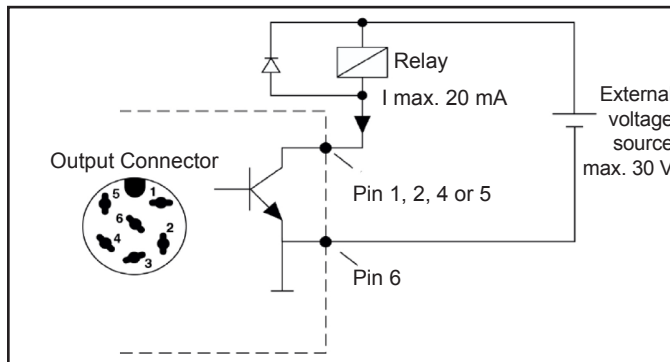

Figure 5. Output connection for use with a controlling device.

Data output connect pin status when using wrist strap/shoe

	Power up:	Test result 1:		Test result 2:		Test result 3:		Test result 4:	
		wrist wrap o.k.	shoe o.k.	wrist wrap not o.k.	shoe o.k.	wrist wrap o.k.	shoe not o.k.	wrist wrap not o.k.	shoe not o.k.
pin 1	hi	hi	hi	lo	hi	hi	lo	lo	lo
pin 2	hi	hi	hi	hi	lo	hi	lo	hi	lo
pin 3	hi	hi	hi	hi	hi	hi	hi	hi	hi
pin 4	hi	hi	lo	hi	hi	hi	hi	hi	hi
pin 5	hi	lo	lo	hi	lo	lo	hi	hi	hi

Figure 6. Data output chart

The sequence for testing must be wrist strap test first and then the shoe test.

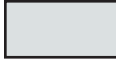
 Shaded pin indicators will read "hi" if the sequence is reversed or only the shoe tests are performed.



Data Output Connector
 pin 1, 2, 4, 5 - high or low
 pin 3 - + 5 V
 pin 6 - DC-return

Calibration

The Wrist Strap and Footwear Tester is calibrated to standards traceable to NIST. Frequency of recalibration should be based on the critical nature of those ESD sensitive items handled and the risk of failure for the ESD protective equipment and materials. In general, we recommend that calibration be performed annually.

The following procedure can be used to determine if the Wrist Strap and Footwear Tester operates within its specifications.

Note: The tester has no adjustable components.

Equipment Needed

Resistors: 750 kilohm - 120 megohm, tolerance $\pm 1\%$
2 leads: as required to connect the reference resistor

Calibration of wrist strap test circuit

Connect the reference resistor to the Wrist Strap and Footwear Tester. Switch the Wrist Strap and Footwear Tester unit on. Select the 2 megohm-range and use the reference resistors as indicated in the test table and press contact plate A.

The LEDs will indicate as shown below if the Wrist Strap and Footwear Tester performs within specifications. Repeat this procedure for 5, 10, 35, 50 and 100 megohm-ranges.

Reference Resistor	Resistance Range Settings	LED Indication
750 kilohm* 900 kilohm 1.8 megohm > 2.2 megohm	2 megohm - range	Red Green Green Red
4.5 megohm > 5.5 megohm	5 megohm - range	Green Red
9.0 megohm > 11.0 megohm	10 megohm - range	Green Red
31.5 megohm > 38.5 megohm	35 megohm - range	Green Red
40 megohm > 60 megohm	50 megohm - range	Green Red
80 megohm > 120 megohm	100 megohm - range	Green Red

*The 750 kilohm threshold is approximate for that range and could vary slightly. Actual threshold resistance are not listed.

Specifications

General

Dimensions of base unit	5.5" W x 2.14" H x 7.5" L (14 cm W x 5.5 cm H x 19 cm L)
Weight	438 g (15.5 oz.)
Accuracy	$\pm 10\%$ of 2, 5, 10, 35 and 50 megohm ranges $\pm 20\%$ of 100 megohm range
Voltage	14VDC (open circuit)

Power

External AC/DC Transformer	24 - 30 VDC/100 megohm range
Output	Open collector at pin 1, 2, 4, 5 (max. 30 V/20mA) DC - return at pin 6, +5V at pin 3

Wrist Strap and Footwear Tester Logbook

Name	Month / Year																															
	1	2	3	4	5	6	7	8	9	10	11	12	13	14	15	16	17	18	19	20	21	22	23	24	25	26	27	28	29	30	31	
	W	S	W	S	W	S	W	S	W	S	W	S	W	S	W	S	W	S	W	S	W	S	W	S	W	S	W	S	W	S	W	S
Test 1																																
Test 2																																
Test 1																																
Test 2																																
Test 1																																
Test 2																																
Test 1																																
Test 2																																
Test 1																																
Test 2																																
Test 1																																
Test 2																																
Test 1																																
Test 2																																
Test 1																																
Test 2																																
Test 1																																
Test 2																																
Test 1																																
Test 2																																
Test 1																																
Test 2																																
Test 1																																
Test 2																																
Test 1																																
Test 2																																
Test 1																																
Test 2																																

Example:

Not ok:

ok:

Name	Month / Year			
	1	2	3	4
Test 1	x	x	x	x
Test 2	x	x	x	x

Test parameters:

Wrist Strap (W) *Shoes (S)*

750 kilohm - 2 megohm 750 kilohm - 10 megohm

5 megohm 35 megohm

10 megohm 50 megohm

35 megohm 100 megohm

Unit calibrated on:

By:

Next calibration on:

Serial number:

Safety Information

Warning

To reduce the risks associated with environmental contamination:
When working with the automated equipment, always observe safety precautions as recommended by equipment manufacturer and your company's practices.

Caution

To reduce the risks associated with environmental contamination:
Dispose of the monitor in accordance with local, state, and federal regulations.

Notice

To reduce the risks associated with property damage:
Periodically check that the indicator is functioning properly.

Regulatory Information

To reduce the risks associated with environmental contamination from the device: At the end of service life, dispose of the unit in accordance with federal, state and local requirements.

WEEE Statement

The following information is only for EU-member States:
The mark shown to the right is in compliance with Waste Electrical and Electronic Equipment Directive 2002/96/EC (WEEE). The mark indicates the requirement NOT to dispose the equipment as unsorted municipal waste, but use the return and collection systems according to local law.

Made in Germany

Limited Warranty, Warranty Exclusions, Limit of Liability and RMA Request Instructions

See the SCS Warranty -
<http://staticcontrol.descoindustries.com/warranty.aspx>