

Spezifikation für Freigabe / specification for release

Kunde / customer :

Artikelnummer / part number :

7490220123



Bezeichnung : LAN-Übertrager WE-LAN

description : LAN-Transformer WE-LAN

DATUM / DATE : 2016-08-09

H PoE Eigenschaften :

Designed für Anwendungen bis 1400mA
 pro Mittelanzapfung
 Designed für 70W Anwendungen wenn zwei Kanäle bestromt
 Designed für 140W Anwendungen wenn vier Kanäle bestromt

H PoE Specifications :

Designed to support applications up to 1400mA
 per centre tap
 Designed for 70W applications when using two channels
 Designed for 140W applications when using four channels

I Schaltbild / Schematics :

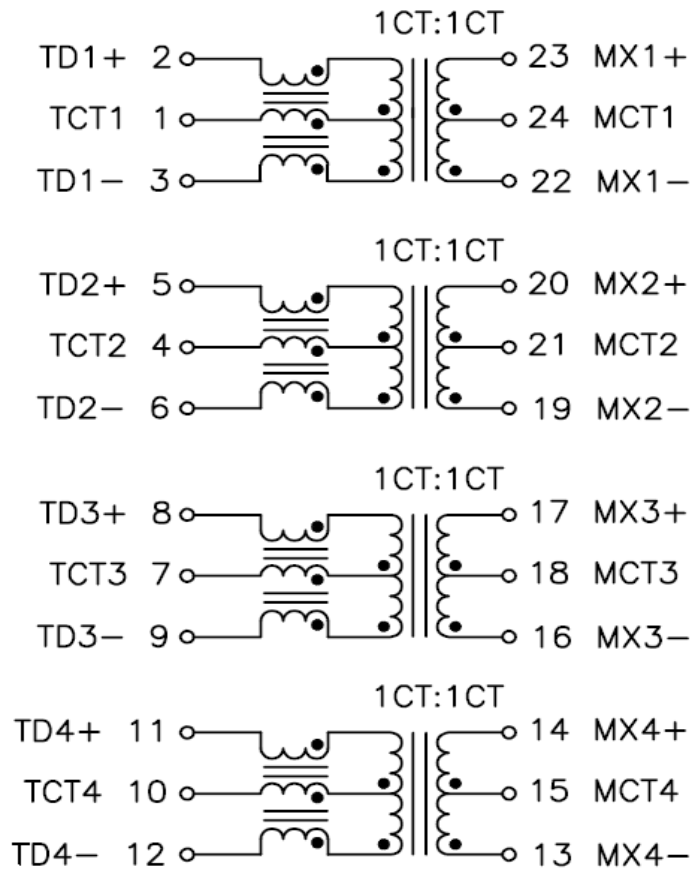

Datum / date	Unterschrift / signature	JaB	Version 03	2016-08-09
	Würth Elektronik	JaB	Version 02	2016-07-26
		JaB	Version 01	2016-04-12
		JLiu	Preliminary	2015-08-18
Geprüft / checked	Kontrolliert / approved	Name	Änderung / modification	Datum / date

Würth Elektronik eiSos GmbH & Co.KG

D-74638 Waldenburg · Max-Eyth-Straße 1 - 3 · Germany · Telefon (+49) (0) 7942 - 945 - 0 · Telefax (+49) (0) 7942 - 945 - 400
<http://www.we-online.com>

Spezifikation für Freigabe / specification for release

Kunde / customer :
 Artikelnummer / part number : **7490220123**
 Bezeichnung : **LAN-Übertrager WE-LAN**
 description : **LAN-Transformer WE-LAN**



DATUM / DATE : 2016-08-09

I Rollenspezifikation / tape and reel specification :

PACKAGING(Tape & Reel)

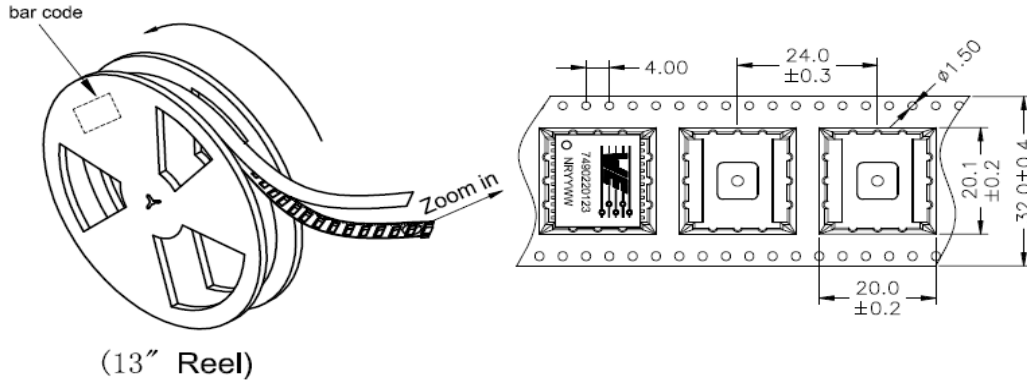

(13" Reel)

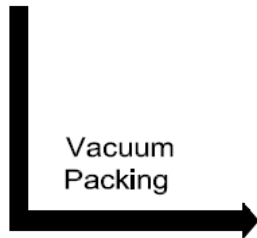

Outside Carton

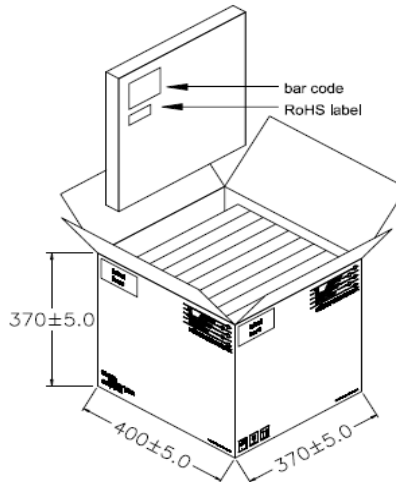

PACKING QUANTITY:

290 pcs Finished Goods / Reel

8 Reels (2320 pcs Finished Goods) / Carton

Freigabe erteilt / general release:	Kunde / customer			
Datum / date	Unterschrift / signature	JaB	Version 03	2016-08-09
	Würth Elektronik	JaB	Version 02	2016-07-26
		JaB	Version 01	2016-04-12
		JLiu	Preliminary	2015-08-18
Geprüft / checked	Kontrolliert / approved	Name	Änderung / modification	Datum / date

This electronic component has been designed and developed for usage in general electronic equipment. Before incorporating this component into any equipment where higher safety and reliability is especially required or if there is the possibility of direct damage or injury to human body, for example in the range of aerospace, aviation, nuclear control, submarine, transportation, (automotive control, train control, ship control), transportation signal, disaster prevention, medical, public information network etc, Würth Elektronik eiSos GmbH must be informed before the design-in stage. In addition, sufficient reliability evaluation checks for safety must be performed on every electronic component which is used in electrical circuits that require high safety and reliability functions or performance.

Würth Elektronik eiSos GmbH & Co.KG

D-74638 Waldenburg · Max-Eyth-Straße 1 - 3 · Germany · Telefon (+49) (0) 7942 - 945 - 0 · Telefax (+49) (0) 7942 - 945 - 400
<http://www.we-online.com>