

## Key Features

- Combined GSM & GPS Functionality
- Quad Band GSM/GPRS & 3G
- Screw/Through-Hole Mount Antenna
- GSM Gain 2.5dBi; GPS LNA Gain 25dB



## Additional Considerations

- Compatible worldwide with any cellular GSM application
- Perfect for covert applications
- Vandal resistant
- Dual mounting – adhesive and screw mount

## General Description

The Tango 15's are a Low profile, robust and vandal proof range of antennas suitable for outdoor equipment like vending machines, traffic light systems and also automotive and many other types of GPS tracking applications. The Tango 15 is 95mm in diameter and only 18mm high.

It is IP65 rated, comes with double sided sticky pad shaped to the antenna and forms a good seal between antenna and the equipment it is mounted to.

The Tango 15 is designed for covert applications where the user wishes to keep their antenna out of sight from unwanted eyes. Operating on GSM & 3G, the Tango 15 works well with various kinds of telemetry equipment, such as Siretta's Zeta and the Zoom terminal series. This antenna combines an active GPS antenna with an LNA (Low Noise Amplifier) so it can be used with GPS applications as well as cellular. Its bolt through base allows the antenna to be securely fixed to the roof of vehicles and its IP65 rating makes it more than suitable for the outdoors.

With an M12 bolt it can be used with a mounting hole of between 13-20mm. The Tango 15 is a solidly made antenna to last for years and is available with various lengths of cable and connector types.

Rev 1.0

## Key Specifications - Electrical

Temperature range:	-40 to +85°C
Impedance:	50ohm
VSWR:	<2.0:1
Average GSM Gain	2.5dBi
GPS (LNA) Gain	25dB
Voltage and supply current:	3 - 5V DC 25mA typical
Operating frequency: GSM/GPRS	890-960 /1710-1880MHz
3G	2100MHz
GPS	1575.42MHz
Polarisation:	GSM – Vertical / GPS – RHCP

## Key Specifications - Mechanical

Dimensions:	ø95 x18mm
Cable:	RG174 1m/3m
Connector:	SMA, TNC, FME BNC, N type as required

## Dimensions

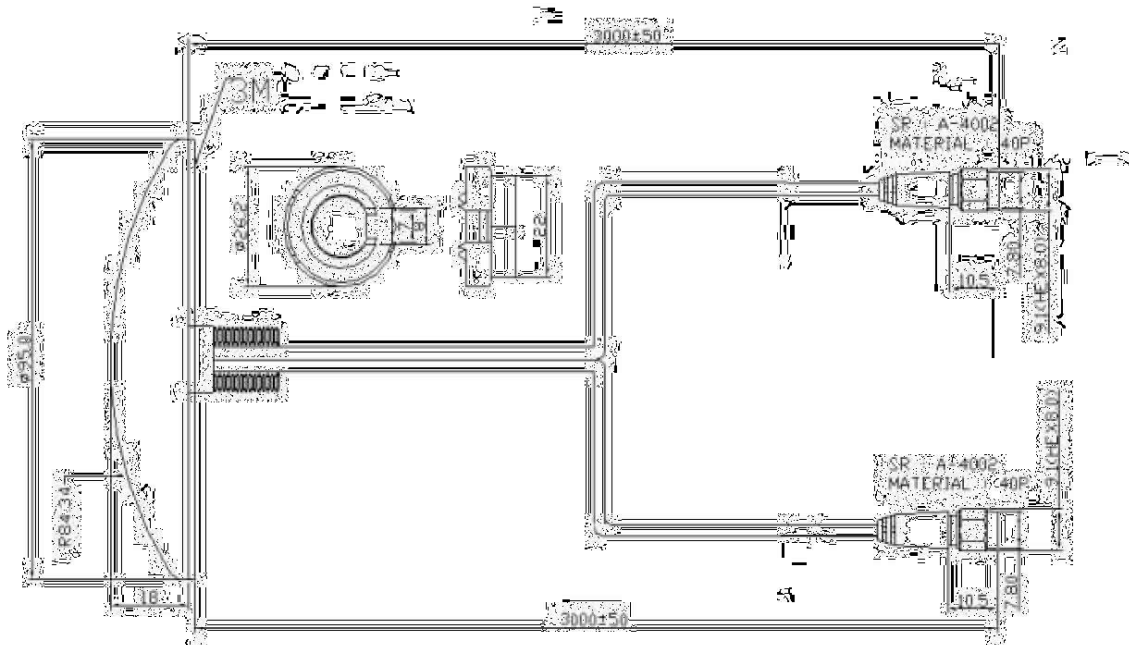

Rev 1.0

GSM Return Loss Graph

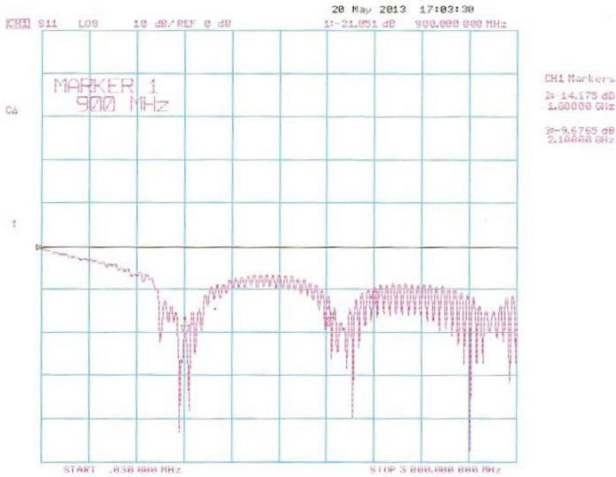

GSM VSWR Graph

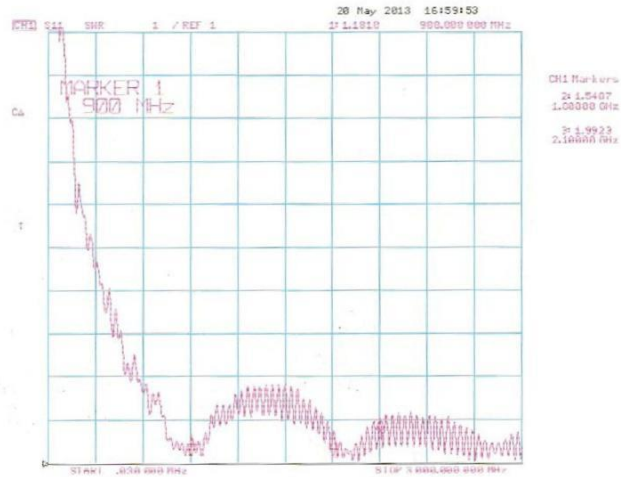

GPS Return Loss Graph

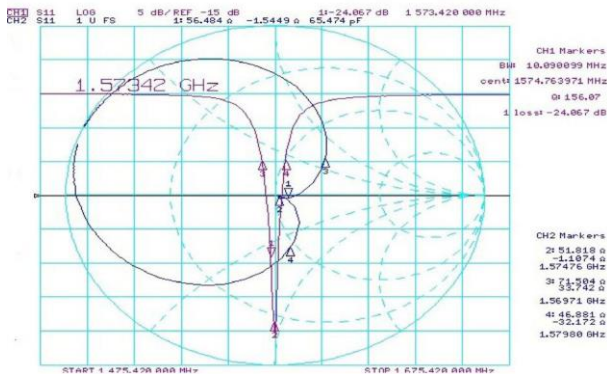

## Ordering Details:

Part number	Description
TANGO15/1M/SMAM/S/S/24	GSM/GPS Combined Bolt Through Antenna with 1 Meter Cable and SMA Male Connector
TANGO15/3M/SMAM/S/S/24	GSM/GPS Combined Bolt Through Antenna with 3 Meter Cable and SMA Male Connector
TANGO15/5M/SMAM//SMAM/S/S/24	GSM/GPS Combined Bolt Through Antenna with 5 Meter Cable and SMA Male Connector

Rev 1.0