



KSZ8851-16MLL

**48-pin Single-Port Ethernet Controller
With 8-bit or 16-bit Non-PCI Interface**

Evaluation Board User's Guide

**Revision 1.1
August 2010**

© Micrel, Inc. 2007
All rights reserved

Micrel is a registered trademark of Micrel and its subsidiaries in the United States and certain other countries. All other trademarks are the property of their respective owners.

The information furnished by Micrel in this datasheet is believed to be accurate and reliable. However, no responsibility is assumed by Micrel for its use. Micrel reserves the right to change circuitry and specifications at any time without notification to the customer. Micrel Products are not designed or authorized for use as components in life support appliances, devices or systems where malfunction of a product can reasonably be expected to result in personal injury. Life support devices or systems are devices or systems that (a) are intended for surgical implant into the body or (b) support or sustain life, and whose failure to perform can be reasonably expected to result in a significant injury to the user.

Micrel, Inc. ♦ 2180 Fortune Drive ♦ San Jose, CA 95131 ♦ U.S.A.
408-944-0800 (voice) ♦ 408-474-1000 (fax)
<http://www.Micrel.com>

A Purchaser's use or sale of Micrel Products for use in life support appliances, devices or systems is at Purchaser's own risk and Purchaser agrees to fully indemnify Micrel for any damages resulting from such use or sale.

Revision History

Revision	Date	Summary of Changes
1.0	2/20/2008	Initial Release
1.1	8/6/2010	Add JP8 for connection between VDD_IO and 1.8V (if VDD_IO is 1.8V). Changed the LED pulled up to 3.3V.

Table of Contents

1.0	Introduction	5
2.0	Board Features	5
3.0	Evaluation Kit Contents.....	5
4.0	Hardware Description	6
4.1	Host Interface	7
4.2	Jumper Setting & Definition	8
4.3	Power Supply and Test Point Definition	9
4.4	RJ-45 Connector and Transformer	9
4.5	EEPROM and LED Indicators	9
4.6	Board Reset.....	10
5.0	Bill of Materials.....	11

List of Figures

Figure 1. KSZ8851-16MLL Evaluation Board..... 6
Figure 2. KSZ8851-16MLL-Eval Host Interface Connection with Spirent SmartBits 7

List of Tables

Table 1. Header JP1 – Host Interface Connection for SD[15:0] 7
Table 2. Header JP1 – Host Interface Connection for Control and Power..... 8
Table 3. KSZ8851-16MLL-Eval Jumper Definition 8
Table 4. KSZ8851-16MLL-Eval Test Point Definition..... 9
Table 5. KSZ8851-16MLL EEPROM Format 9
Table 6. KSZ8851-16MLL-Eval Port Status LED Definition 10
Table 7. KSZ8851-16MLL-Eval LED Definition 10

1.0 Introduction

The KSZ8851-16MLL-Eval Evaluation Board is intended to provide a convenient and fast way to evaluate or demonstrate the functionality and performance of this new Single-Port Ethernet Controller KSZ8851-16MLL device from Micrel.

The KSZ8851-16MLL comes with a 48-pin, lead-free LQFP (7mm x 7mm) package and provides an ideal solution for applications requiring high-performance from single-port Ethernet Controller with 8-bit or 16-bit generic processor interface. The KSZ8851-16MLL offers the most cost-effective solution for adding high-throughput Ethernet connectivity to traditional embedded systems.

This evaluation board is designed as a stand alone without microcontroller or M16C on board. By default the KSZ8851-16MLL-Eval board comes with an operation of 16-bit bus mode, Little Endian mode and disabled EEPROM for KSZ8851-16MLL device. Customer may wire the board for his desired interface. The purpose is to provide a simple tool that can be used to evaluate the KSZ8851-16MLL device by connecting via headers to customer provided Microcontroller or Non-PCI hardware platform.

Micrel provides a basic software driver based on the 8 or 16-bit bus solution and different operating system platforms to evaluate the KSZ8851-16MLL functionality and performance. The software includes a configuration utility to allow quick and easy device setup, initialization and transmit/receive packet. All KSZ8851-16MLL configuration pins and host interface signals are accessible either by jumpers, test points or headers.

2.0 Board Features

- One KSZ8851-16MLL 48-pin Single-Port Ethernet Controller with shared data bus for host interface
- Single +5V/GND power input from headers
- RJ-45 Jack for Fast Ethernet cable interface
- HP Auto-MDIX for automatic detection and correction for straight-through and crossover cables
- Two on board LDO voltage regulators, one for VDD_IO and the other for VDD_A3.3
- One AT93C46 for external EEPROM interface
- Two LED indicators for port status and activity
- One LED indicator for 3.3V output ready
- One LED indicator for Power Management Event (PME) output status
- Jumpers to configure strapping pins and VDD_IO voltage option
- Headers to wire the host interface from external hardware platform
- Manual reset button for quick reboot after re-configuration of strapping pins

3.0 Evaluation Kit Contents

The KSZ8851-16MLL Evaluation Kit includes the following hardware:

- KSZ8851-16MLL Evaluation Board

The KSZ8851-16MLL Data Sheet and Hardware Design Package with the following collaterals that can be downloaded from Micrel's website at <http://www.micrel.com>

- KSZ8851-16MLL Eval Board Schematic (PDF and OrCAD DSN file)
- KSZ8851-16MLL Eval Board Gerber File (PDF version included)
- KSZ8851-16MLL Eval Board User's Guide (this document and included BOM)
- KSZ8851-16MLL IBIS Model

4.0 Hardware Description

The KSZ8851-16MLL-Eval (shown in Figure 1) comes in a compact form factor and plugs directly into industry standard test equipment such as Spirent SmartBits, the other side of board is wired to external host interface through headers. Configuration of the KSZ8851-16MLL is accomplished through on-board jumper selections and/or by register access via the host shared data/control bus Interface.

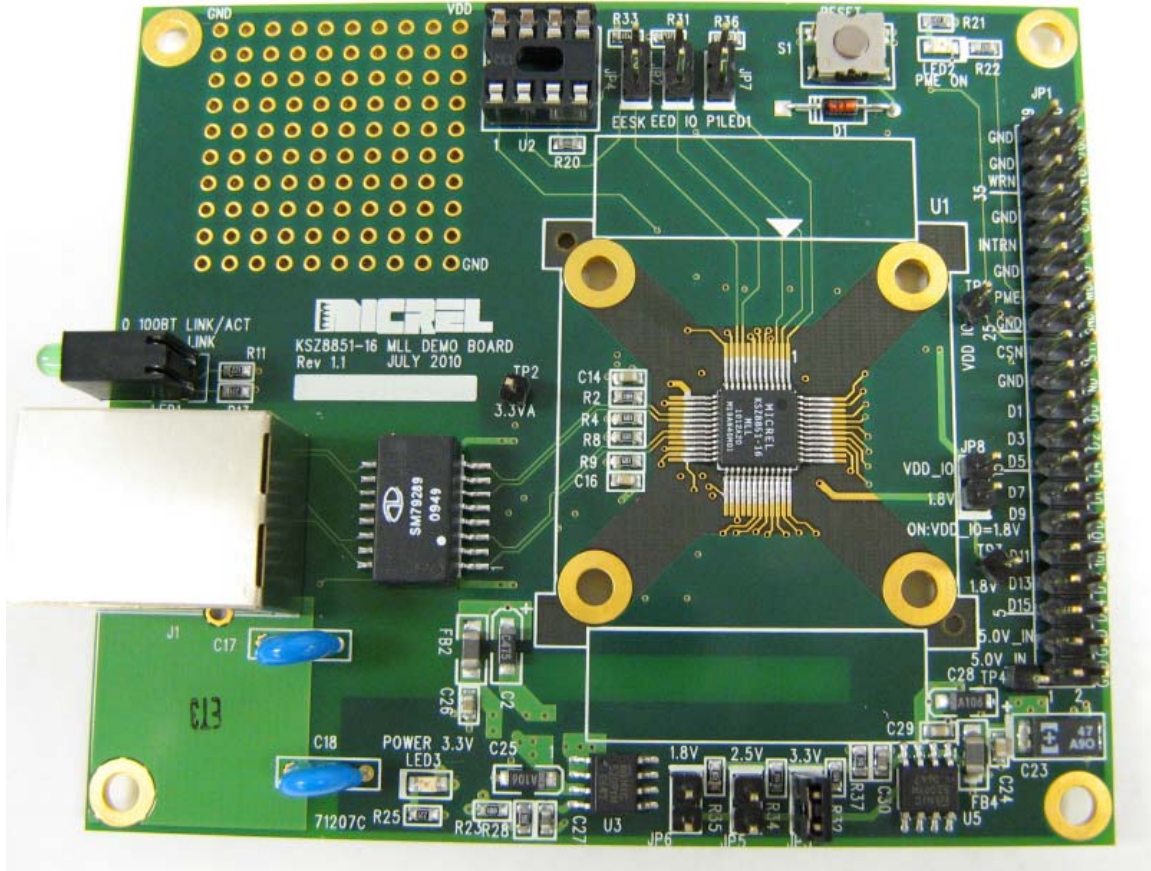

Figure 1. KSZ8851-16MLL Evaluation Board (Rev 1.1)

Other features include a RJ-45 Jack for Fast Ethernet cable connection, transformer (Pulse H1102) to block DC level and provide a true AC coupling, EEPROM (Atmel AT93C46) to load MAC address when it is enabled, jumper to select LDO output for VDD_IO voltage, programmable LED indicators for reporting port link status and activity, and a manual reset button for quick reboot after re-configuration of strapping pins.

The KSZ8851-16MLL-Eval receives +5V DC input power supply from its Headers JP1.

4.1 Host Interface

The KSZ8851-16MLL-Eval board receives +5V power from the header JP1 (pin 1/3). Figure 2 shows the Host interface connection with Spirent SmartBits for system set-up and performance test.

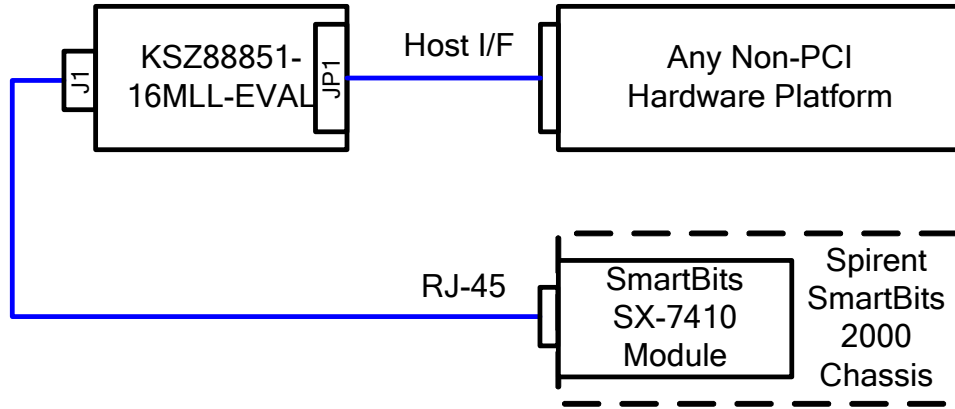

Figure 2. KSZ8851-16MLL-Eval Host Interface Connection with Spirent SmartBits

The KSZ8851-16MLL-Eval has a 40-pin header (JP1) for Host interface to external any Non-PCI hardware platform. Table 1 lists Shared Data SD[15:0] pin outs for the Host interface on header JP1. Table 2 lists the rest of control signals and power/ground pin outs for the Host interface on header JP1.

Pin # (JP1)	Shared Data Bus Signal	16-Bit Bus Mode (pin 1 pull-up)		8-Bit Bus Mode (pin 1 pull down)	
		CMD = 0 (low)	CMD = 1 (high)	CMD = 0 (low)	CMD = 1 (high)
20	SD0	D0	x (don't care)	D0	A0
19	SD1	D1	x (don't care)	D1	A1
18	SD2	D2	A2	D2	A2
17	SD3	D3	A3	D3	A3
16	SD4	D4	A4	D4	A4
15	SD5	D5	A5	D5	A5
14	SD6	D6	A6	D6	A6
13	SD7	D7	A7	D7	A7
12	SD8	D8	x (don't care)	GND	GND
11	SD9	D9	x (don't care)	GND	GND
10	SD10	D10	x (don't care)	GND	GND
9	SD11	D11	x (don't care)	GND	GND
8	SD12	D12	BE0	GND	GND
7	SD13	D13	BE1	GND	GND
6	SD14	D14	BE2	GND	GND
5	SD15	D15	BE3	GND	GND

Table 1. Header JP1 – Host Interface Connection for SD[15:0]

Pin # (JP1)	Power & Control Signal Names	Description
1, 3	5.0V_IN	+5V power supply inputs for this board
2, 4, 21, 22, 25, 26, 29, 33, 34, 37, 38, 39, 40	GND	Ground inputs/pins
23	CPU_CSN	Chip Select input from host CPU
24	CPU_RSTN	Reset input from host CPU
27	CPU_PME	Power Management Event output to host CPU
28	CPU_CMD	Command type input from host CPU
31	CPU_INTRN	Interrupt output to host CPU
35	CPU_WRN	Write input from host CPU
36	CPU_RDN	Read input from host CPU
30, 32	Spares	For customer to use

Table 2. Header JP1 – Host Interface Connection for Control and Power

4.2 Jumper Setting & Definition

The KSZ8851-16MLL-Eval does not require any jumper for normal operation except the VDD_IO option. During power-up, the KSZ8851-16MLL is configured using the chip's internal pull-up and pull-down resistors with its default strapping pin values which will set this device in operation of 16-bit bus mode, little endian and without EEPROM. Jumpers are provided to override the default settings, allowing for quick configuration and re-configuration of the board. To override the default settings, simply select and close the desired jumper setting(s) and toggle the on-board manual reset button (S1) for the new setting(s) to take effect.

The KSZ8851-16MLL-Eval jumper settings are defined in Table 3 below.

Jumper	Definition	Setting	Description
JP2	EED_IO	OFF (Default)	OFF: EEPROM is not present ON: EEPROM is present
JP3	3.3V	ON (Default)	ON: to select 3.3V for VDD_IO (JP5 and JP6 must be OFF) OFF: De-select 3.3V
JP4	EESK	OFF (Default)	OFF: Little Endian ON: Big Endian
JP5	2.5V	OFF (Default)	ON: to select 2.5V for VDD_IO (JP3 and JP6 must be OFF) OFF: De-select 2.5V
JP6	1.8V	OFF (Default)	ON: to select 1.8V for VDD_IO (JP3 and JP5 must be OFF) OFF: De-select 1.8V
JP7	P1LED1	OFF (Default)	OFF: 16-Bit bus mode ON: 8-Bit bus mode
JP8	VDD_IO	OFF (Default)	OFF: VDD_IO = 2.5V or 3.3V ON: VDD_IO = 1.8V

Table 3. KSZ8851-16MLL-Eval Jumper Definition

Power Supply and Test Point Definition

The KSZ8851-16MLL-Eval is supplied from external +5.0V DC power through a jumper (pin 1 and 3 at JP1), this +5.0V DC input is converted to both +3.3V with a Micrel LDO voltage regulator (U3, MIC5209BM) for VDD_A3.3 analog power and VDD (option for 3.3V, 2.5V or 1.8V) with a Micrel LDO voltage regulator (U5, MIC5209BM) for VDD_IO digital power. The KSZ8851-16MLL contains an internal +1.8V LDO, to provide its core, analog and PLL voltages.

The KSZ8851-16MLL-Eval has four test points. They are defined in the following Table 4.

Test Point	Definition
TP1	Power supply measurement for VDD_IO
TP2	Power supply measurement for VDD_A3.3
TP3	1.8V digital core voltage output measurement from KSZ8851-16MLL internal LDO
TP4	External power supply 5.0V_IN measurement

Table 4. KSZ8851-16MLL-Eval Test Point Definition

4.3 RJ-45 Connector and Transformer

The RJ-45 Jack (J1) connects to standard CAT-5 Ethernet cable to interface with 10Base-T/100Base-TX Ethernet devices. The LAN interface on the KSZ8851-16MLL is connected to a transformer (T1) with 50 ohm termination resistors for both TX+/- and RX+/- differential pairs. The line side of the transformer is connected to the RJ-45 connectors (J1).

J1 also supports Auto-MDIX and Auto-Negotiation / Forced Modes.

4.4 EEPROM and LED Indicators

It is optional in the KSZ8851-16MLL to use an external EEPROM. The EED_IO (JP2) must be pulled high (ON) to use external EEPROM.

An external serial EEPROM with a standard microwire bus interface is used for non-volatile storage of information such as the host MAC address. The KSZ8851-16MLL can detect if the EEPROM is either a 1KB (93C46) or 4KB (93C66) EEPROM device. The EEPROM must be organized as 16-bit mode.

The KSZ8851-16MLL EEPROM format is given in Table 5.

WORD	15	8	7	0
0H	Reserved			
1H	Host MAC Address Byte 2		Host MAC Address Byte 1	
2H	Host MAC Address Byte 4		Host MAC Address Byte 3	
3H	Host MAC Address Byte 6		Host MAC Address Byte 5	
4H – 6H	Reserved			
7H-3FH	Not used for KSZ8851-16MLL (available for user to use)			

Table 5. KSZ8851-16MLL EEPROM Format

A dual LED indicator (LED1) is located adjacent to the RJ-45 Connector (J1). The top LED is connected to P1LED1 (pin 1) and bottom LED is connected to P1LED0 (pin 2) of the KSZ8851-16MLL.

The two LEDs are programmable to LED mode '0' or '1' via register 0xC6 bits [9], and are defined in the following Table 6.

	LED Mode	
	0 (Default)	1
LED1 (Top)	100BT	ACT
LED1 (Bottom)	LINK/ACT	LINK

Table 6. KSZ8851-16MLL-Eval Port Status LED Definition

Table 7 shows the rest of LEDs definition.

LED	Color	Description
LED2	Green	Power Management Event (PME) Status
LED3	Red	3.3V Power available indicator

Table 7. KSZ8851-16MLL-Eval LED Definition

4.5 Board Reset

The KSZ8851-16MLL-Eval generates a reset signal from the reset circuitry during power up. It also provides a push button S1 reset circuit to reset the KSZ8851-16MLL device. During power up, the board is automatically reset. User can also press reset button S1 on the board for a manual reset.

5.0 Bill of Materials

KSZ8851-16MLL Eval Board (Revision 1.1)

KSZ8851-16MLL DEMO BOARD Revision: 1.1

MICREL SEMICONDUCTOR All Components must be Lead free / RoHS compliant
DNI = DO NOT INSTALL

Bill Of Materials

Item	QTY	Reference	Value / Size	Mfg	Mfg Part #	Digi-key	DNI
1	4	C1,C2,C3,C6	4.7uF Tan A	Nichicon	F931A475MAA		
2	13	C4,C5,C7,C9,C10,C11,C12,C14,C16,C20,C24,C26,C29	0.1uF 0603	Panasonic	ECJ-1VB1C104K		
3	2	C8,C13	0.01uF 0603	Panasonic	ECJ-1VB1H103K		
4	4	C15,C19,C25,C28	10uF Tan A		F931A106MAA		
5	2	C18,C17	1000pF/2KV	Panasonic	ECK-A3D102KBP		
6	2	C21,C22	22pF 0603	Panasonic	ECJ-1VC1H220J		
7	1	C23	47uF Tan C	Kemet	T491C476K010AT		
8	2	C30,C27	470pF 0603	Yageo	CC0603KRX7R9BB471		
9	1	D1	1N4148 DIP	Micro Commercial Co.	1N4148-TP	1N4148-TPMSTR-ND	
10	2	D2,D3 (for reference & not design in)	GBLC03C_0	SOD-323			DNI
11	4	FB1,FB2,FB3,FB4	FERRITE 3A 100 OHM 1206 SMD	Steward	HI1206N101R-00		
12	1	JP1	HEADER 20x2 (TH 0.1mm)				
13	6	JP2,JP3,JP4,JP5,JP6,JP7,JP8	Header & JUMPER SIP/2P				
14	1	J1	RJ45 connetor	RAYCON	RT-TGJAS-R1FT08/08		
15	1	LED1	LEDx2 Green	Dialight	553-0122-300F	350-1699-ND	
16	2	LED2 (green)	LED GRN 0805 SMD	Lumex	SML-LXT0805GW-TR	67-1553-1-ND	
		LED3 (red)	LED RED 0805 SMD	Lumex	SML-LXT0805IW-TR	67-1552-1-ND	
17a	4	RN1,RN2,RN3,RN4	33 x 4 (resistor net)			744C083330JPTR-ND	
17b	7	R10,R12,R14,R16,R17,R18,R22	33 0603				
18	2	R1,R20	0 0603				
19	4	R2,R4,R8,R9	49.9 0603				
20	4	R3,R5,R6,R7	75 0603				
21	4	R11,R13,R21,R25	220 0603				
22	1	R15	10K 0603				
23	1	R19	3.01K 1% 0603				
24	2	R32,R23	1.5K 1% 0603				
25	7	R24,R26,R27,R29,R30,R31,R33	4.7K 0603				
26	2	R37,R28	2.49K 1% 0603				
27	1	R34	2.46K 1% 0603				
28	1	R35	5.54K 1% 0603				
29	1	R36	1K 0603				
30	1	S1	SW PUSHBUTTON	Panasonic	EVQ-PHP03T		
31	4	TP1,TP2,TP3,TP4	TestPoint				
32	1	T1	SINGLE H1102NL (or HX1188NL)	PULSE	H1102NL (or HX1188NL)	553-1323-ND or 553-1340-ND	
33	1	U1	KSZ8851-16MLL (48-pin 7mmx7mm LQFP)		Micrel		
34	1	U2	AT93C46-10SC EEPROM DIP	ATMEL	AT93C46	IC install w/Socket	DNI
35	2	U3,U5	MIC5209YM	SOIC-8	Micrel		
36	1	U4 (for reference & not design in)	SRV05-4	SOT23-6			DNI
37	1	Y1	(cylindrical)	Epson Electronic	CA-301 25.0000M-C-PBFREE	SER3441-ND	