

# 740 Wrist Strap and Footwear Tester Installation, Operation and Maintenance



Figure 1. SCS 740 Wrist Strap and Footwear Tester

## Description

The SCS 740 Wrist Strap and Footwear Tester meets ANSI/ESD S20.20 per ESD TR53 Compliance Verification testing of personnel grounding devices. The 740 Wrist Strap and Footwear Tester is an electronic test instrument that is easy to operate and designed to be wall-mounted. A power adapter is supplied. The 740 Wrist Strap and Footwear Tester switches off automatically after non-use for approximately 30 minutes.

The unit consists of two measurement circuits with an open circuit test voltage of 14V for wrist strap and Footwear test applications. For wrist strap and footwear testing, a minimum threshold resistance of 750 kilohm is set internally. The desired maximum allowable resistance level can be selected separately for each measurement. If the resistance of the tested wrist strap or footwear is within the selected range, the green "O.K." LED will illuminate. The red "<" LED alerts the operator that the resistance of the tested device is under 750 kilohm. The red ">" LED indicates that the selected maximum resistance is exceeded.

The 740 Wrist Strap and Footwear Tester can be connected to external devices such as computers (for data recording), electrical door opening systems, or other logic driven components.

The 740 Wrist Strap and Footwear Tester and its accessories are available as the following item numbers:

Item	Description
<a href="#">740</a>	Wrist Strap and Footwear Tester, North America
<a href="#">740E</a>	Wrist Strap and Footwear Tester, Europe
<a href="#">741</a>	Single Foot Plate, for 740 Tester
<a href="#">741D</a>	Dual Foot Plate, for 740E Tester
<a href="#">741DC</a>	Foot Plate Cable, for 741D Foot Plate
<a href="#">740P</a>	Power Adapter, North America Plug
<a href="#">740E-X</a>	Power Adapter, Europe Plug

## Features and Components

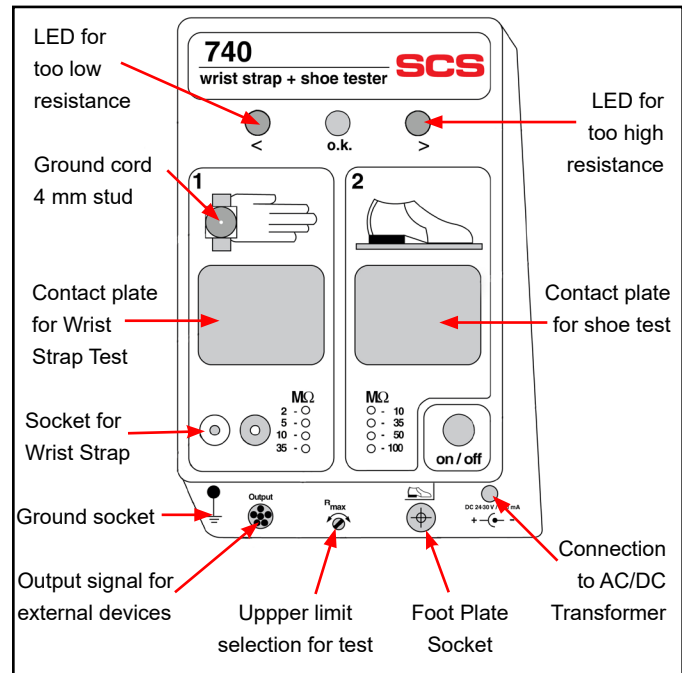

Figure 2. 740 Wrist Strap and Footwear Tester features and components

## Packaging

- 1 Wrist Strap and Footwear Tester
- 1 Wall Mounting Kit (Dual Lock Fasteners)
- 1 Power Adapter

## Installation

1. Remove the tester from the carton and inspect for damage.
2. Determine the installation location of the tester. The enclosed dual lock fastening discs must be screwed to the wall using the attached template approximately 1.5m (5 feet) above the floor. Drill three holes of 5mm (0.2 inches) diameter at marked locations. Make sure the area on the tester in which the dual lock fastening strips are placed is free of dust and dirt. Attach the dual lock fastening strips to the back of the tester to the bottom and top in parallel; see drawing for locations.

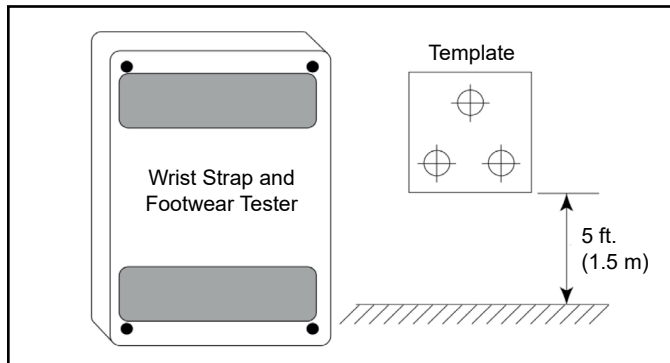

Figure 3. Using the Dual Lock Fastening Discs for mounting

3. Press the tester firmly against the discs to secure it to the wall. For removal of the tester, lift the top corners with both hands.
4. Connect the included ground cord to the ground socket located on the bottom-side of the tester. Attach the other end of the cord to a ground point. The face plate screw of a grounded AC wall outlet may provide a convenient connection point.
5. If using the optional 741 or 741D Foot Plate, connect the foot plate cord to the foot plate jack located on the bottom-side of the tester. Connect the opposite end of the cord to its corresponding foot plate.
6. Connect the power adapter to the power jack located on the bottom-side of the tester. Route the wire from the supply to a nearby AC outlet and plug it into the outlet. Make sure the voltage and frequency match those listed on the power supply.
7. Press the ON/OFF switch to power the tester. All LEDs will flash for approximately 1 second. Select the desired upper test limit for both the wrist strap and footwear by using a small screw driver to turn the switch located on the bottom-side of the tester.



## Wrist Strap Test

Put the wristband on with ground cord attached and insert the ground cord into the wrist strap jack. Depress the metal contact plate and hold it. One of the indicator-LEDs will illuminate.

An illuminated green LED indicates that the wrist strap performs within the resistance range of 750 kilohm to the upper selected value of 2, 5, 10 or 35 megohm. If a red "<"-LED is on, the current limiting resistor in the ground cord is bypassed and the cord has to be replaced. The red ">"-LED indicates that the selected resistance range is exceeded. Check to see if the high resistance is in the cord, the wristband or in the contact between wristband and the operator's skin. To check the resistance of the ground cord, leave the plug end of the ground cord attached to the tester and disconnect the snap end from the wristband. Connect ground cord snap to the stud in the hand symbol or press it onto the contact plate and depress the plate until one of the LEDs is illuminated.

If the green LED illuminates now, the ground cord can be used.

If the red ">"-LED is lit, replace the ground cord.

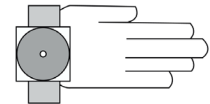

In some cases, high contact resistance between the skin and wristband will cause the tester to show a red ">"-LED condition. This resistance may be caused by dry skin or the presence of hair in the wrist area. The use of a skin lotion is recommended to solve this problem.

If a red ">"-LED condition still exists, replace the wristband. Or the presence of hair in the wrist area. The use of a skin lotion is recommended to solve this problem.

If a red ">"-LED condition still exists, replace the wristband.

## Footwear Test

Stand on the foot plate. If you are using footwear with a 1 megohm resistor on both feet to be tested with the foot plate, you have to test the straps one after the other, to avoid a fail low test result. Care must be taken not to put the non-tested foot on ESD protective flooring to avoid a bypass to ground. Press the metal contact plate for footwear test until one of the test LEDs illuminate.

The green LED indicates that the resistance of the person through the footwear is in the range between 750 kilohm and the desired upper maximum level (10, 35, 50 or 100 megohm).

# Data Output Connector

If you are going to use the data output connector, you must follow a test sequence. Test the wrist strap first and then the Footwear. **If this sequence is not strictly kept, the output at the pins described in Figure 6 will be incorrect.**

The Wrist Strap and Footwear Tester will provide digital signals (high/low) while testing the personnel grounding devices. These digital signals can be used for data recording (Figure 4) and authorization control equipment such as electrical door opening systems (Figure 5). The output of the Wrist Strap and Footwear Tester will give you permanently + 5V at pin 3 and DC-return at pin 6. The remaining pins 1, 2, 4 and 5 (open collector) will be high (max. +30V / 20mA have to be provided externally) or low (DC-return) while pressing on the contact plates either for wrist strap or Footwear tests. The chart in Figure 6 shows all of the possible test results and the corresponding output levels.

# Data output connect pin status when using wrist strap/Footwear

	Power up:	Test result 1:		Test result 2:		Test result 3:		Test result 4:	
		wrist wrap o.k.	shoe o.k.	wrist wrap not o.k.	shoe o.k.	wrist wrap o.k.	shoe not o.k.	wrist wrap not o.k.	shoe not o.k.
pin 1	hi	hi	hi	lo	hi	hi	lo	lo	lo
pin 2	hi	hi	hi	hi	lo	hi	lo	hi	lo
pin 3	hi	hi	hi	hi	hi	hi	hi	hi	hi
pin 4	hi	hi	lo	hi	hi	hi	hi	hi	hi
pin 5	hi	lo	lo	hi	lo	lo	hi	hi	hi

Figure 6. Data output chart

The sequence for testing must be wrist strap test first and then the Footwear test.

 Shaded pin indicators will read "hi" if the sequence is reversed or only the Footwear tests are performed.



Data Output Connector  
 pin 1, 2, 4, 5 - high or low  
 pin 3 - + 5 V  
 pin 6 - DC-return

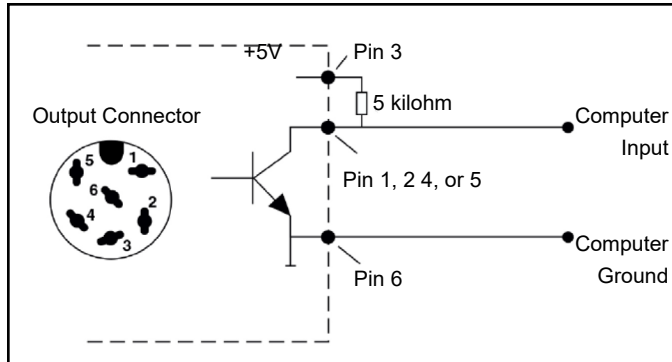

Figure 4. Output connection for use with a computer.

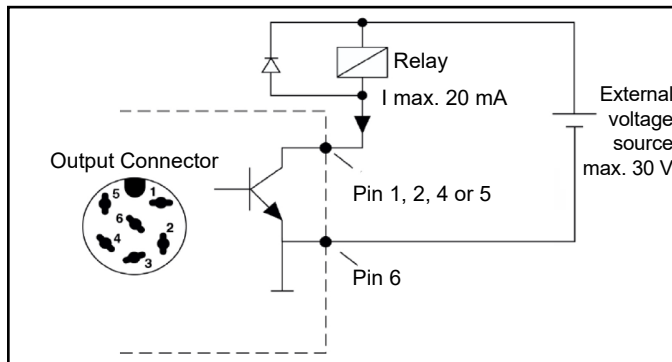

Figure 5. Output connection for use with a controlling device.

## Calibration

The Wrist Strap and Footwear Tester is calibrated to standards traceable to NIST. Frequency of recalibration should be based on the critical nature of those ESD sensitive items handled and the risk of failure for the ESD protective equipment and materials. In general, we recommend that calibration be performed annually.

The following procedure can be used to verify if the tester operates within its specifications.

NOTE: The tester has no adjustable components.

### EQUIPMENT NEEDED

- Resistance Decade Box (750 kilohm to 120 megohm range,  $\pm 1\%$  tolerance)
- 2 Test Leads for the Resistance Decade Box

### TESTING THE WRIST STRAP CIRCUIT

1. Power the tester ON.
2. Connect the two test leads to the resistance decade box.
3. Connect one test lead to the ground jack located at the bottom of the tester. Connect the second test lead to the wrist strap test plate.
4. Set the tester to the 2 megohms test limit.
5. Set the resistance decade box to the values shown in the table below. Press the wrist strap test plate for all 4 resistance values listed in the 2 megohms row. The LEDs should illuminate as indicated in the table.

Test Limit Setting	Load Resistance	LED Result
2 megohms	750 kilohms* 900 kilohms 1.8 megohms > 2.2 megohms	Red Green Green Red
5 megohms	4.5 megohms > 5.5 megohms	Green Red
10 megohms	9.0 megohms > 11.0 megohms	Green Red
35 megohms	31.5 megohms > 38.5 megohms	Green Red

6. Repeat this procedure for the 5, 10 and 35 megohm test limits.

\*The 750 kilohm threshold is approximate for that range and could vary slightly. Actual threshold resistance are not listed.

## Specifications

### General

Dimensions of base unit	5.5" W x 2.14" H x 7.5" L (14 cm W x 5.5 cm H x 19 cm L)
Weight	438 g (15.5 oz.)
Accuracy	$\pm 10\%$ of 2, 5, 10, 35 and 50 megohm ranges $\pm 20\%$ of 100 megohm range
Voltage	14VDC (open circuit)

### Power

External AC/DC Transformer	24 - 30 VDC/100 megohm range
Output	Open collector at pin 1, 2, 4, 5 (max. 30 V/20mA) DC - return at pin 6, +5V at pin 3

# Wrist Strap and Footwear Tester Logbook

Name	Month / Year																															
	1	2	3	4	5	6	7	8	9	10	11	12	13	14	15	16	17	18	19	20	21	22	23	24	25	26	27	28	29	30	31	
	W	S	W	S	W	S	W	S	W	S	W	S	W	S	W	S	W	S	W	S	W	S	W	S	W	S	W	S	W	S	W	S
Test 1																																
Test 2																																
Test 1																																
Test 2																																
Test 1																																
Test 2																																
Test 1																																
Test 2																																
Test 1																																
Test 2																																
Test 1																																
Test 2																																
Test 1																																
Test 2																																
Test 1																																
Test 2																																
Test 1																																
Test 2																																
Test 1																																
Test 2																																
Test 1																																
Test 2																																
Test 1																																
Test 2																																
Test 1																																
Test 2																																
Test 1																																
Test 2																																
Test 1																																
Test 2																																
Test 1																																
Test 2																																
Test 1																																
Test 2																																
Test 1																																
Test 2																																

**Example:**

Not ok:

ok:

Name	Month / Year			
	1	2	3	4
Test 1	x	x	x	x
Test 2	x	x	x	x

**Test parameters:**

*Wrist Strap (W)*      *Shoes (S)*

750 kilohm - 2 megohm       750 kilohm - 10 megohm

5 megohm       35 megohm

10 megohm       50 megohm

35 megohm       100 megohm

Unit calibrated on:

By:

Next calibration on:

Serial number:

## Safety Information

### Warning

To reduce the risks associated with environmental contamination:  
When working with the automated equipment, always observe safety precautions as recommended by equipment manufacturer and your company's practices.

### Caution

To reduce the risks associated with environmental contamination:  
Dispose of the monitor in accordance with local, state, and federal regulations.

### Notice

To reduce the risks associated with property damage:  
Periodically check that the indicator is functioning properly.

## Regulatory Information

To reduce the risks associated with environmental contamination from the device: At the end of service life, dispose of the unit in accordance with federal, state and local requirements.

### WEEE Statement

The following information is only for EU-members States:  
The mark shown to the right is in compliance with Waste Electrical and Electronic Equipment Directive 2002/96/EC (WEEE). The mark indicates the requirement NOT to dispose the equipment as unsorted municipal waste, but use the return and collection systems according to local law.

Made in Germany

### Limited Warranty, Warranty Exclusions, Limit of Liability and RMA Request Instructions

See the SCS Warranty -  
<http://staticcontrol.descoindustries.com/Limited-Warranty.aspx>