

INSTRUCTIONS

for INSTALLATION OPERATION and MAINTENANCE

POWERSTAT® VARIABLE TRANSFORMERS

WITH POWERKOTE® COILS
126-226 Series

The right to make engineering refinements on all products is reserved. Dimensions and other details are subject to change.



Superior Electric

28 SPRING LANE • SUITE 3
FARMINGTON, CT 06032 USA
www.superiorelectric.com

Telephone and Fax Numbers
Telephone 860-507-2025
Fax 860-507-2050
Customer Service 860-507-2025, Ext. 70782
Product Application 860-507-2025, Ext. 72058

Toll-Free (in USA and Canada only)
Telephone 1-800-787-3532
Fax 1-800-821-1369
Customer Service 1-800-787-3532, Ext. 70782
Product Application 1-800-787-3532, Ext. 72058



Printed in USA

TEMPLATE NO. 2

NOTE: All dimensions are in inches [millimeters]

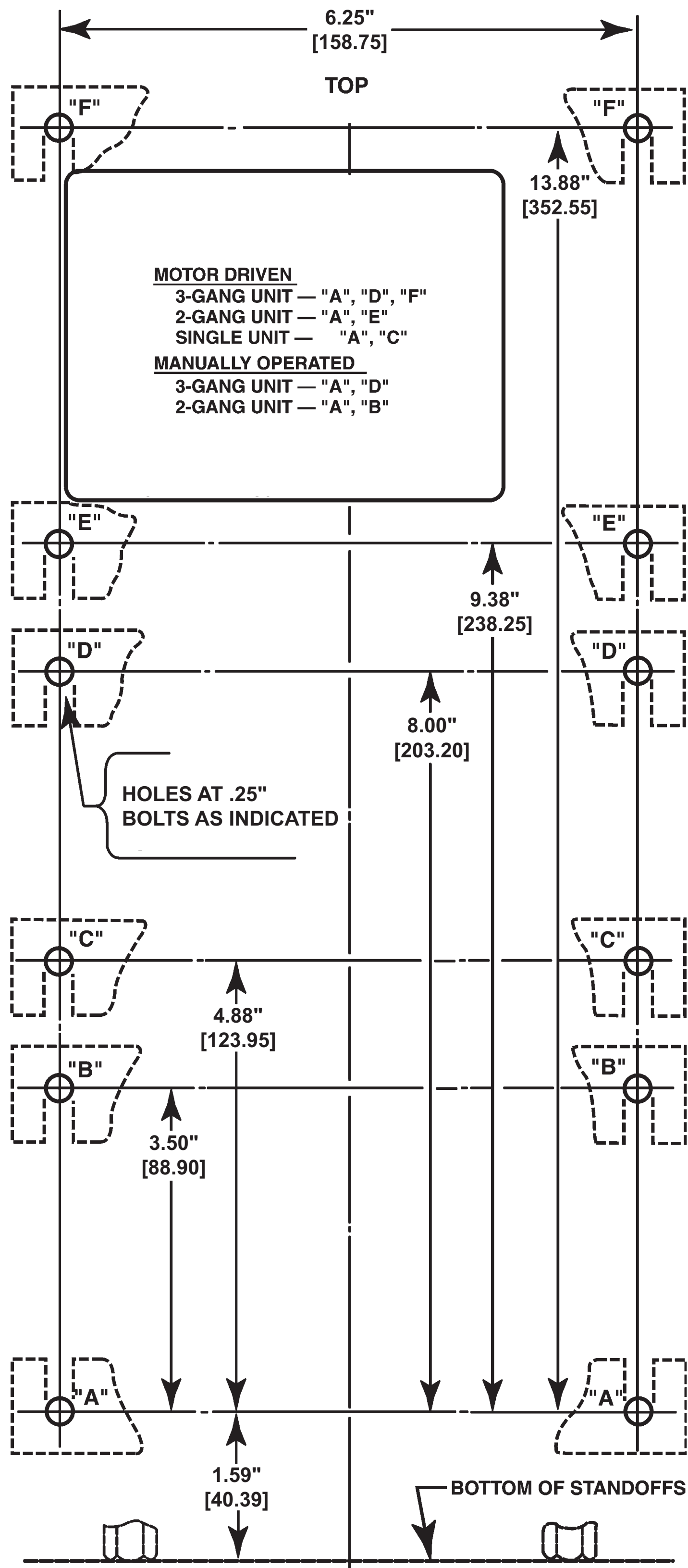

INSPECTION

A POWERSTAT Variable Transformer is a precision product packed with care. When unpacking, examine carefully for any shipping damage. Inspect the brush contact with particular care. The "Damage and Shortage" instructions packed with the unit outline the proper procedure to follow if any parts are damaged or missing.

INSTALLATION

NOTE: The unit should be protected from any dust or debris that may be encountered while drilling holes, installing wiring, etc., during installation.

MANUALLY OPERATED ASSEMBLIES

POWERSTAT Variable Transformer types 126 and 226 have two sets of mounting holes to facilitate installation in new or existing layouts. Use the set that is most convenient for the application. All models are designed so that the same unit can be either bench or back-of-panel mounted as desired. The units as shipped are arranged for bench mounting. To change to back-of-panel mounting, proceed as outlined.

SINGLE UNITS

The 3PN model, has a cord and plug input and a receptacle output, and is usually used as a portable source of variable a-c voltage. If desired they may be mounted in the same manner as other manually operated single units.

BENCH OR WALL MOUNTING

1. Locate and drill for mounting bolt holes "A" using Drilling Template No. 1. Three pilot holes in the base (identified as "B" on template) may also be used if desired. These pilot holes are .157" x .167" in diameter by 13/32" deep to accommodate #10 self-tapping screws. When these holes are used, it is necessary to have access to the rear of the mounting surface.

2. Place the unit in position. Insert and tighten the mounting bolts. For mounting holes "B", the length of the bolts must not exceed the thickness of the mounting surface plus 3/8".

BACK-OF-PANEL MOUNTING

1. Using Drilling Template No. 1, locate and drill the four mounting bolt holes "A", the dial screw holes "C" and the center shaft hole. Maximum panel thickness is 3 inches. The dial screw holes must be tapped to accommodate the 6-32 screws supplied. Three pilot holes in the base (holes "B" on template) may also be used if desired. The holes are .157" x .167" in diameter by 13/32" deep to accommodate #10 self-tapping screws. Flat head screws must be used, since they will be partially covered by the dial.

2. Loosen the knob setscrews and remove the knob. Remove the dial and mount it to the panel with the three 6-32 screws.

3. Loosen the shaft setscrews (at the base end of the shaft) and slide the shaft through so it will project about 13/16" through the panel after installation. Tighten the setscrews.

4. Place the unit in position, insert and tighten the mounting bolts. Be sure that the mounting bolt length does not exceed the panel thickness plus 3/8" when using holes "B". Place the knob on the shaft and position the pointer correctly with respect to the brush position and the dial indications. Tighten the knob setscrews.

GANGED ASSEMBLIES

BENCH OR WALL MOUNTING

A. On Standoffs
1. Locate and drill the mounting bolt holes (four holes "A") using Drilling Template No. 1.
2. Place the unit in position. Insert and tighten the mounting bolts. When access to the rear of the mounting panel is not possible, the unit may be mounted to an adapter plate and the adapter plate mounted to the panel using lag screws. Additional support in the form of a shelf or cradle should be provided when wall mounting these units.

B. On Side Brackets
1. Locate and drill the four mounting bolt holes using Drilling Template No. 2. BE SURE TO USE THE PROPER SET OF HOLES.
2. Insert and screw in part way the two top mounting bolts.
3. Place the unit in position and insert the two bottom bolts. Tighten all bolts.

4. Place the unit in position, insert and tighten the mounting bolts. Be sure that the mounting bolt length does not exceed the panel thickness plus 3/8" when using holes "B". Place the knob on the shaft and position the pointer correctly with respect to the brush position and the dial indications. Tighten the knob setscrews.

5. Place the unit in position and insert the two bottom bolts. Tighten all bolts.

BACK-OF-PANEL MOUNTING

1. Locate and drill the four mounting bolt holes "A", the three dial screw holes "C" and the center shaft hole using Drilling Template No. 1. Maximum panel thickness is 3". The three dial screw holes must be tapped to accommodate the 6-32 screws supplied.

2. Remove the knob and dial. Loosen the shaft setscrews (at the base end of each unit) and slide the shaft through so it will project about 13/16" through the panel after installation. Turn the radiators of the units to the extreme counterclockwise position and tighten the shaft setscrews.

3. Mount the dial to the panel with the 6-32 screws supplied.

4. Place the unit in position. Insert and tighten four 1/4-28 mounting bolts. Mounting bolts are supplied with the unit for use with panels to 3/4" thick. For thicker panels use 1/4-28 bolts 3/8" longer than the panel thickness. A ganged assembly, because of its added length and weight, requires extra support in the form of a shelf or cradle.

5. Place the knob on the shaft and position the pointer correctly with respect to the brush position and the dial indications. Tighten the setscrews.

MOTOR-DRIVEN ASSEMBLIES

Motor-driven POWERSTAT Variable Transformers of the 126-226 Series, both single units and ganged assemblies, may be bench or wall mounted in the same manner as manually operated ganged assemblies. Three-gang assemblies, however, have three side brackets requiring six bolts.

MAINTENANCE

With ordinary care, a POWERSTAT Variable Transformer should require no servicing except possible replacement of the brush assembly. The brush should be inspected periodically and replaced if arcing takes place or if it is badly worn. Because the brush must be of a special material, replace only with a Superior Electric brush assembly listed below. The assembly is designed to assure perfect contact of the brush to the commutator regardless of brush position and length of time in use. Take care to avoid scraping, scratching or marring the commutator surface. Follow these steps to install a new brush assembly:

1. Remove the plate block above the terminal panel.
2. Unfasten the brush assembly anchor screws, remove and discard the old brush assembly.
3. Insert the new brush assembly in the radiator slot, replace the anchor screws and tighten to the radiator. Be sure that the back end of the brush strap is under the projections at the rear of the radiator brush slot.
4. Raise the brush and place a piece of sandpaper (grit #400 or finer) between the commutator surface and the brush so that the smooth side is on the commutator and the abrasive side is against the carbon brush.
5. While holding the sandpaper in place (flat), rotate the radiator through a short arc. Remove the sandpaper and blow out the excess carbon particles.

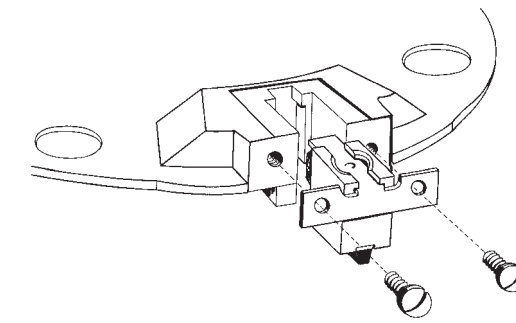

FIGURE
BRUSH ASSEMBLY

REPLACEMENT BRUSH ASSEMBLIES

MODEL NUMBER	PART NUMBER	DESCRIPTION
126	122819-001	RB126
226	122819-002	RB226

Whenever unusual mechanical or electrical difficulties are encountered in the operation or installation of your POWERSTAT Variable Transformer, consult Superior Electric.

CONNECTIONS AND RATINGS

Important connection notes. Please read carefully.

- CONNECTIONS AND RATINGS given in these instructions are those most commonly used. In addition, all ganged units may be connected so that the units operate electrically independent on a common shaft. When this is desired, connections and ratings for a single deck unit should be used.
- For ambient temperatures between -20°C and +50°C use current ratings given in the charts. Figure A shows the output current de-rating required above 50°C.
- Coil to terminal connections for all 126 and 226 Series units are shown in Figures B, C, and D.
- The connection diagrams are labeled "L" for Line Connections, "B" for Boost Connections and "S" for Step-Up Connections.
- The F226 Series POWERSTAT® Variable Transformers do not have terminals 6 & 7 available and therefore do not have a Step-Up ("S") Connection. Terminal #3 is after the fuse on all F models.
- For the Step-Up Connections the tables show maximum output current rating for output voltages up to 125% of the input voltage, and maximum KVA at maximum output voltage. The output current must be reduced according to

the curve in Figure E for output voltages greater than 125% of input voltage. Maximum KVA may be calculated using the rating curve in Figure E for voltages less than maximum.

• Clockwise (CW) and counterclockwise (CCW) rotation connections shown in the tables and diagrams are for motor driven units and units with the knob on the radiator end. For connections with the knob on the base end, use the shown CCW connection for CW operation, and shown CW connection for CCW operation.

• Fuses are recommended on all units as shown (S) and are supplied on F and 3PN models. Supplied fuses are 15 ampere on 126 types, and 8 ampere on 226 types.

• COMMON shown in the connection diagrams is used as third leg in 3-phase open delta, or neutral in single-phase 3-wire and 3-phase 4-wire wye configurations. COMMON is not used in single-phase 2-wire or 3-phase 3-wire wye configurations. Jumper(s) provided in standard common position should be moved or removed as required.

• Motor drive wiring is shown in Figure F.

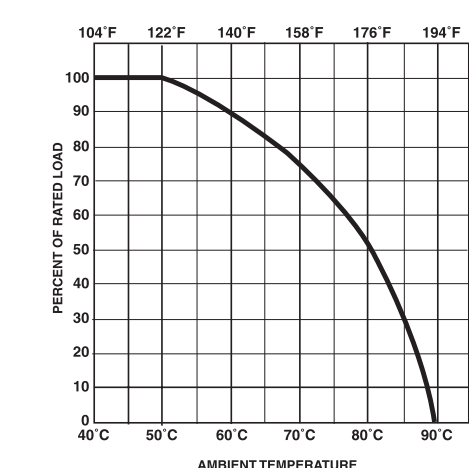

OPERATION AT TEMPERATURES ABOVE 50°C
FIGURE A

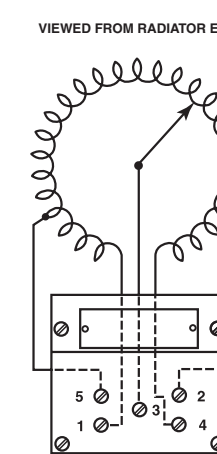

126 TYPES
FIGURE B

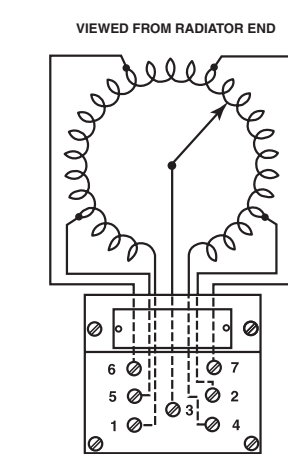

226 TYPES
FIGURE C

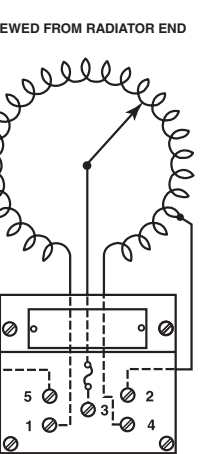

126 AND
F226 TYPES
FIGURE D

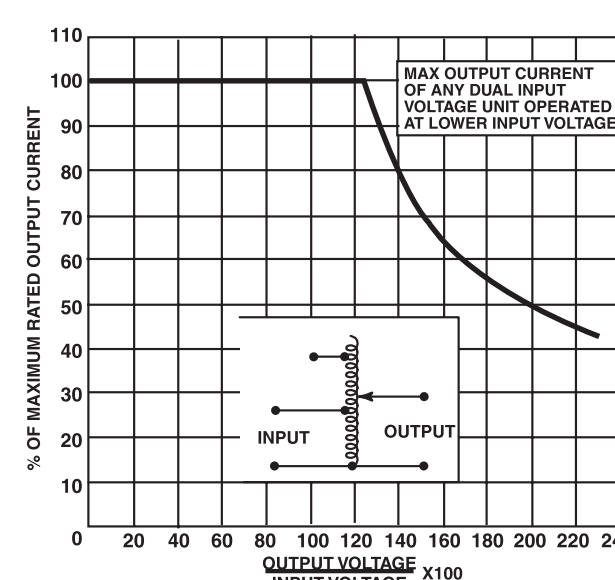

OPERATION IN "STEP-UP" CONNECTION
FIGURE E

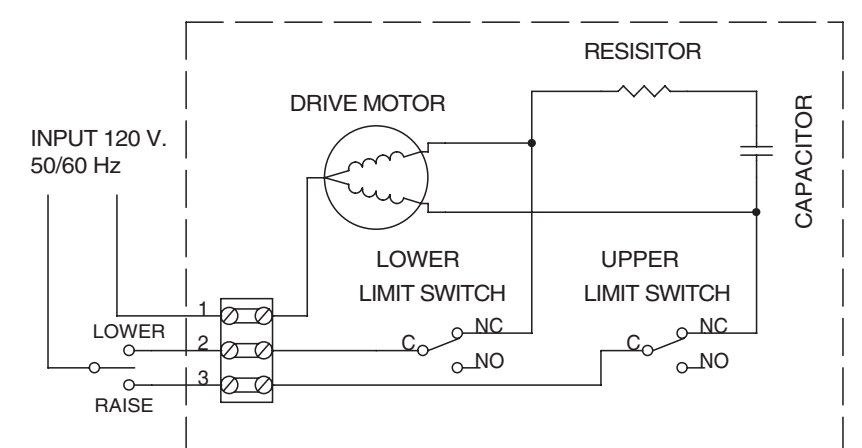

MOTOR DRIVE WIRING
FIGURE F

CONNECTION DIAGRAMS

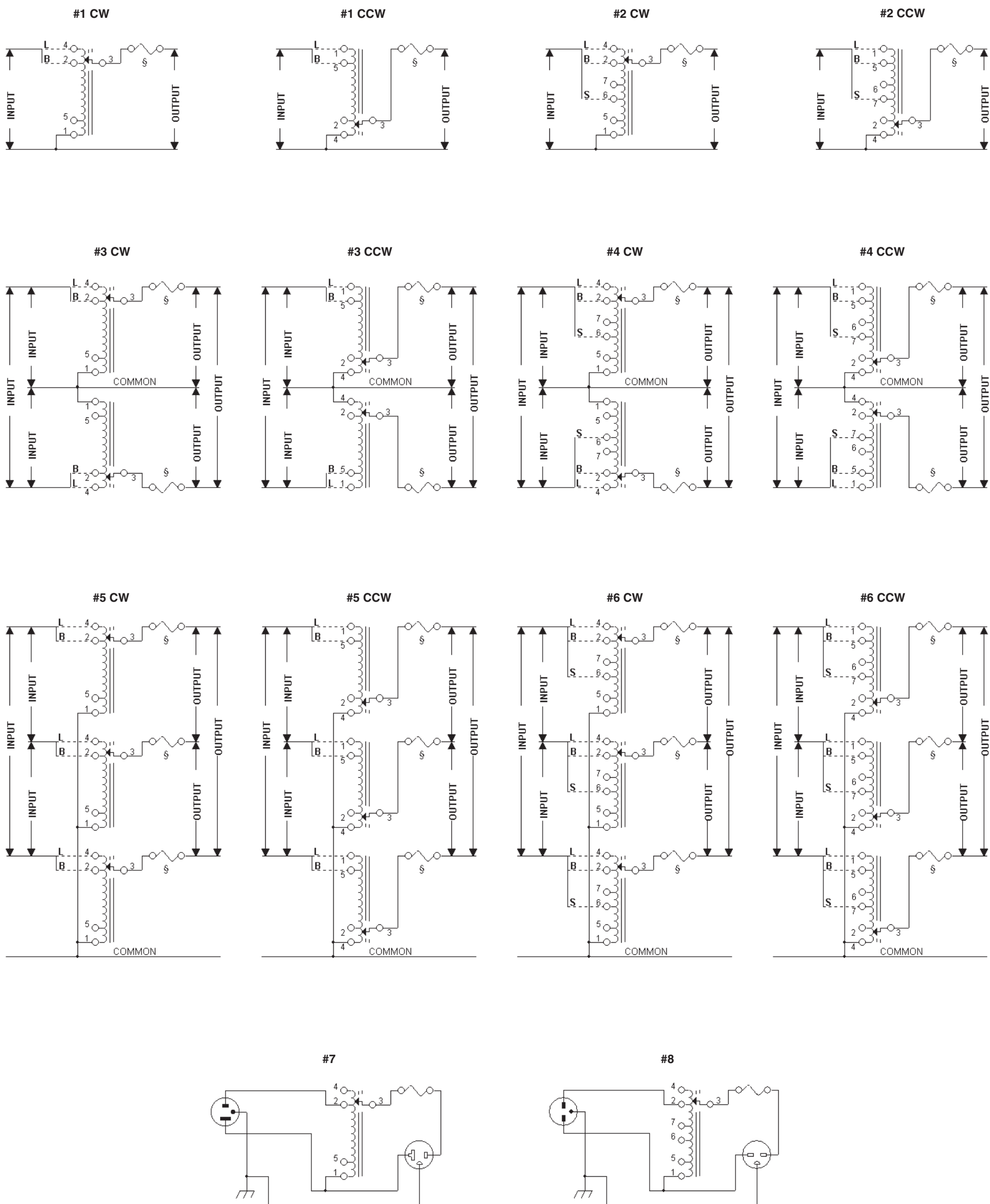

TEMPLATE NO. 1

NOTE: All dimensions are in inches [millimeters]

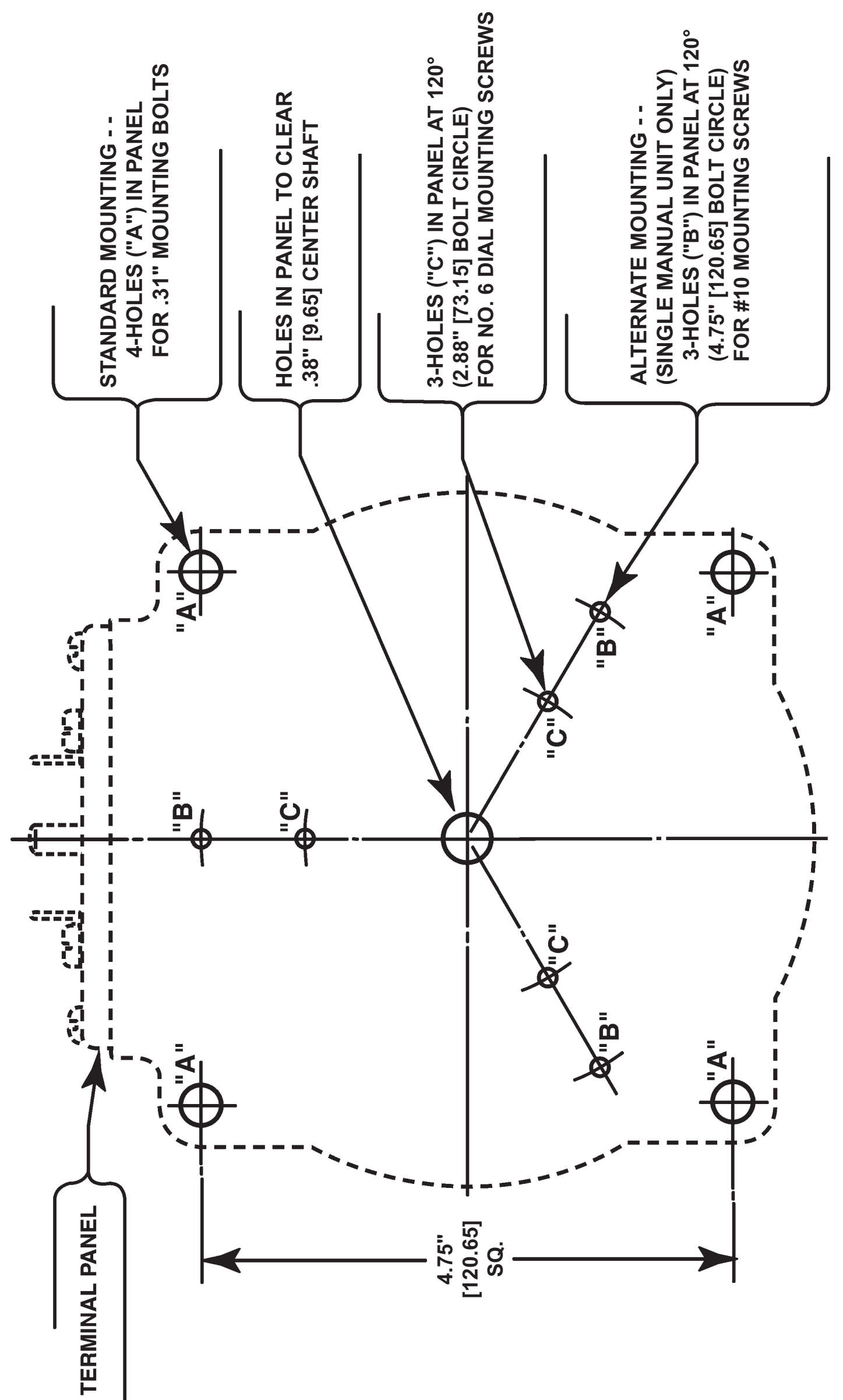

RATINGS CHART

120 VOLT, SINGLE PHASE																												
"LINE" CONNECTION				"BOOST" CONNECTION				"STEP-UP" CONNECTION				Model Numbers		Conn. Diag.														
Input Voltage:	Output Voltage:			Constant Current Load			Terminals & Rotation			Constant Current Load			Terminals & Rotation			Manually Operated	Motor Driven											
Freq. (Hz)	Max. Amps	Max. KVA	Max. Amps	Max. KVA	Max. Amps	Max. KVA	Input CW CCW	Output CW CCW	Jumper CW CCW	Freq. (Hz)	Max. Amps	Max. KVA	Input CW CCW	Output CW CCW	Jumper CW CCW	Freq. (Hz)	Max. Amps	Max. KVA	Input CW CCW	Output CW CCW	Jumper CW CCW	126	MC126					
50/60	15	1.8	20	2.4	1-4	1-4	1-3	3-4	1-1	50/60	15	2.1	1-2	4-5	1-3	3-4	126U	MC126U	MC126U	MC126U	MC126U	3PN126	1	7				
240 VOLT, SINGLE PHASE																												
"LINE" CONNECTION				"BOOST" CONNECTION				"STEP-UP" CONNECTION				Model Numbers		Conn. Diag.														
Input Voltage:	Output Voltage:			Constant Current Load			Terminals & Rotation			Constant Current Load			Terminals & Rotation			Manually Operated	Motor Driven											
Freq. (Hz)	Max. Amps	Max. KVA	Max. Amps	Max. KVA	Max. Amps	Max. KVA	Input CW CCW	Output CW CCW	Jumper CW CCW	Freq. (Hz)	Max. Amps	Max. KVA	Input CW CCW	Output CW CCW	Jumper CW CCW	Freq. (Hz)	Max. Amps	Max. KVA	Input CW CCW	Output CW CCW	Jumper CW CCW	226	MC226					
50/60	7.5	1.8	10	2.4	1-4	1-4	1-3	3-4	1-1	50/60	7.5	2.1	1-2	4-5	1-3	3-4	50/60	7.5	0.91	1-6	4-7	1-3	3-4	226	MC226			
50/60	15	3.6	20	4.8	4-4	1-1	3-3	3-3	1-1	50/60	15	4.2	2-2	5-5	3-3	3-3	1-1	4-4	126U-2	MC126U-2	3PN226	2	8					
480 VOLT, SINGLE PHASE																												
"LINE" CONNECTION				"BOOST" CONNECTION				"STEP-UP" CONNECTION				Model Numbers		Conn. Diag.														
Input Voltage:	Output Voltage:			Constant Current Load			Terminals & Rotation			Constant Current Load			Terminals & Rotation			Manually Operated	Motor Driven											
Freq. (Hz)	Max. Amps	Max. KVA	Max. Amps	Max. KVA	Max. Amps	Max. KVA	Input CW CCW	Output CW CCW	Jumper CW CCW	Freq. (Hz)	Max. Amps	Max. KVA	Input CW CCW	Output CW CCW	Jumper CW CCW	Freq. (Hz)	Max. Amps	Max. KVA	Input CW CCW	Output CW CCW	Jumper CW CCW	226U-2	MC226U-2					
50/60	7.5	3.6	10	4.8	4-4	1-1	3-3	3-3	1-1	50/60	7.5	4.2	2-2	5-5	3-3	3-3	1-1	4-4	50/60	7.5	1.8	6-6	7-7	3-3	1-1	4-4	226U-2	MC226U-2
600 VOLT, SINGLE PHASE																												
"LINE" CONNECTION				"BOOST" CONNECTION				"STEP-UP" CONNECTION				Model Numbers		Conn. Diag.														
Input Voltage:	Output Voltage:			Constant Current Load			Terminals & Rotation			Constant Current Load			Terminals & Rotation			Manually Operated	Motor Driven											
Freq. (Hz)	Max. Amps	Max. KVA	Max. Amps	Max. KVA	Max. Amps	Max. KVA	Input CW CCW	Output CW CCW	Jumper CW CCW	Freq. (Hz)	Max. Amps	Max. KVA	Input CW CCW	Output CW CCW	Jumper CW CCW	Freq. (Hz)	Max. Amps	Max. KVA	Input CW CCW	Output CW CCW	Jumper CW CCW	226U-2	MC226U-2					
60	7.5	4.5	10	6	4-4	1-1	3-3	3-3	1-1	60	7.5	4.5	4-4	1-1	3-3	3-3	1-1	4-4	226U-2	MC226U-2	3PN226	4	4					
120 VOLT, THREE PHASE OPEN DELTA																												
"LINE" CONNECTION				"BOOST" CONNECTION				"STEP-UP" CONNECTION				Model Numbers		Conn. Diag.														
Input Voltage:	Output Voltage:			Constant Current Load			Terminals & Rotation			Constant Current Load			Terminals & Rotation			Manually Operated	Motor Driven											
Freq. (Hz)	Max. Amps	Max. KVA	Max. Amps	Max. KVA	Max. Amps	Max. KVA	Input CW CCW	Output CW CCW	Jumper CW CCW	Freq. (Hz)	Max. Amps	Max. KVA	Input CW CCW	Output CW CCW	Jumper CW CCW	Freq. (Hz)	Max. Amps	Max. KVA	Input CW CCW	Output CW CCW	Jumper CW CCW	126U-2	MC126U-2					
50/60	15	3.1	20	4.2	4-4	1-1	3-3	3-3	1-1	50/60	15	3.6	2-1	5-5	3-3	3-3	1-1	4-4	50/60	15	1.6	6-1	7-7	3-3	1-1	4-4	126U-2	MC126U-2
240 VOLT, THREE PHASE OPEN DELTA																												
"LINE" CONNECTION				"BOOST" CONNECTION				"STEP-UP" CONNECTION				Model Numbers		Conn. Diag.														
Input Voltage:	Output Voltage:			Constant Current Load			Terminals & Rotation			Constant Current Load			Terminals & Rotation			Manually Operated	Motor Driven											
Freq. (Hz)	Max. Amps	Max. KVA	Max. Amps	Max. KVA	Max. Amps	Max. KVA	Input CW CCW	Output CW CCW	Jumper CW CCW	Freq. (Hz)	Max. Amps	Max. KVA	Input CW CCW	Output CW CCW	Jumper CW CCW	Freq. (Hz)	Max. Amps	Max. KVA	Input CW CCW	Output CW CCW	Jumper CW CCW	226U-2	MC226U-2					
50/60	7.5	3.1	10	4.2	4-4	1-1	3-3	3-3	1-1	50/60	7.5	3.6	2-1	5-5	3-3	3-3	1-1	4-4	50/60	7.5	1.6	6-1	7-7	3-3	1-1	4-4	226U-2	MC226U-2
240Y/138 VOLT, THREE PHASE WYE																												
"LINE" CONNECTION				"BOOST" CONNECTION				"STEP-UP" CONNECTION				Model Numbers		Conn. Diag.														
Input Voltage:	Output Voltage:			Constant Current Load			Terminals & Rotation			Constant Current Load			Terminals & Rotation			Manually Operated	Motor Driven											
Freq. (Hz)	Max. Amps	Max. KVA	Max. Amps	Max. KVA	Max. Amps	Max. KVA	Input CW CCW	Output CW CCW	Jumper CW CCW	Freq. (Hz)	Max. Amps	Max. KVA	Input CW CCW	Output CW CCW	Jumper CW CCW	Freq. (Hz)	Max. Amps	Max. KVA	Input CW CCW	Output CW CCW	Jumper CW CCW	126U-3	MC126U-3					
50/60	15	6.2	20	8.3	4-4	1-1	3-3	3-3	1-1	60	15	7.3	2-2	5-5	3-3	3-3	1-1	4-4	50/60	15	3.2	6-6	7-7	3-3	1-1	4-4	126U-3	MC126U-3
480Y/277 VOLT, THREE PHASE WYE																												
"LINE" CONNECTION				"BOOST" CONNECTION				"STEP-UP" CONNECTION				Model Numbers		Conn. Diag.														
Input Voltage:	Output Voltage:			Constant Current Load			Terminals & Rotation			Constant Current Load			Terminals & Rotation			Manually Operated	Motor Driven											
Freq. (Hz)	Max. Amps	Max. KVA	Max. Amps	Max. KVA	Max. Amps	Max. KVA	Input CW CCW	Output CW CCW	Jumper CW CCW	Freq. (Hz)	Max. Amps	Max. KVA	Input CW CCW	Output CW CCW	Jumper CW CCW	Freq. (Hz)	Max. Amps	Max. KVA	Input CW CCW	Output CW CCW	Jumper CW CCW	226U-3	MC226U-3					
50/60	7.5	6.2	10	8.3	4-4	1-1	3-3	3-3	1-1	60	7.5	7.3	2-2	5-5	3-3	3-3	1-1	4-4	60	7.5	3.2	6-6	7-7	3-3	1-1	4-4	226U-3	MC226U-3
600Y/346 VOLT, THREE PHASE WYE																												
"LINE" CONNECTION				"BOOST" CONNECTION				"STEP-UP" CONNECTION				Model Numbers		Conn. Diag.														
Input Voltage:	Output Voltage:			Constant Current Load			Terminals & Rotation			Constant Current Load			Terminals & Rotation			Manually Operated	Motor Driven											
Freq. (Hz)	Max. Amps	Max. KVA	Max. Amps	Max. KVA	Max. Amps	Max. KVA	Input CW CCW	Output CW CCW	Jumper CW CCW	Freq. (Hz)	Max. Amps	Max. KVA	Input CW CCW	Output CW CCW	Jumper CW CCW	Freq. (Hz)	Max. Amps	Max. KVA	Input CW CCW	Output CW CCW	Jumper CW CCW	226U-3	MC226U-3					
60	7.5	7.8	10	10.4	4-4	1-1	3-3	3-3	1-1	60	7.5	7.8	4-4	1-1	3-3	3-3	1-1	4-4	60	7.5	3.2	6-6	7-7	3-3	1-1	4-4	226U-3	MC226U-3

Please read important connection notes on other side.