

MALE-MALE ADAPTER

R125.703.001

Series : SMA

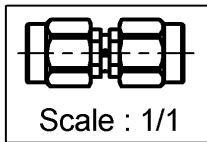
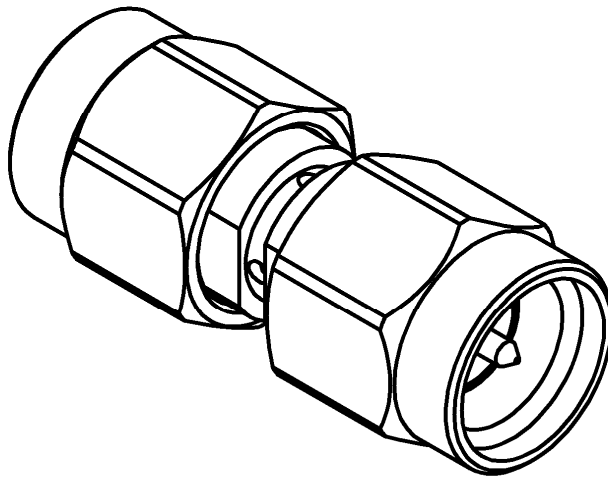
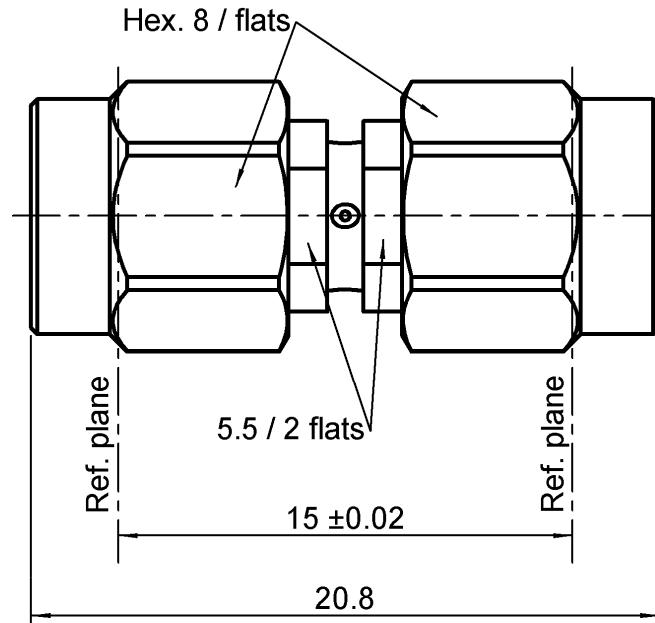

All dimensions are in mm.

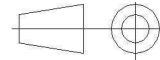

COMPONENTS	MATERIALS	PLATING (µm)
BODY	STAINLESS STEEL	PASSIVATED
CENTER CONTACT	BRASS	GOLD 2.5 OVER NICKEL 2
OUTER CONTACT	-	-
INSULATOR	PTFE	-
GASKET	SILICONE RUBBER	-
OTHERS PARTS	STAINLESS STEEL	PASSIVATED
-	-	-
-	-	-

Issue : 0931 C

In the effort to improve our products, we reserve the right to make changes judged to be necessary.



MALE-MALE ADAPTER

R125.703.001

Series : SMA

PACKAGING

SPECIFICATION

Standard	Unit	Other
100	'W' option	Contact us

ELECTRICAL CHARACTERISTICS

ENVIRONMENTAL

Impedance	50	Ω
Frequency	0-18	GHz
VSWR	1.05 + 0,0050	x F(GHz) Maxi
Insertion loss	0.05	\sqrt{F} (GHz) dB Maxi
RF leakage	- (100)	- F(GHz)) dB Maxi
Voltage rating	500	Veff Maxi
Dielectric withstanding voltage	1000	Veff mini
Insulation resistance	5000	M Ω mini

Operating temperature	-65/+165	$^{\circ}$ C
Hermetic seal	NA	Atm.cm3/s
Panel leakage	NA	

OTHER CHARACTERISTICS

Assembly instruction **NA**

Others :
-

MECHANICAL CHARACTERISTICS

Center contact retention		
Axial force – Mating end	27	N mini
Axial force – Opposite end	27	N mini
Torque	2.8	N.cm mini
Recommended torque		
Mating	90	N.cm
Panel nut	NA	N.cm
Mating life	500	Cycles mini
Weight	4,9000	g

Issue : 0931 C

In the effort to improve our products, we reserve the right to make changes judged to be necessary.

