

**Panasonic**  
ideas for life

## MULTI-RANGE ANALOG TIMER

# S1DXM-A/M Timers

UL File No.: E122222  
C-UL File No.: E122222



### FEATURES

#### 1. Multiple functions built in

The operation mode and time range can be switched by using the MODE and RANGE switches on the front panel.

#### 2. Part number consolidation

- 1) The lineup consists of 64 easy-to-choose models.
- 2) An operation mode fixed type (S1DXM-A) and 4-operation mode switching type (S1DXM-M) are available.

#### 3. Cadmium-free contacts used

To eliminate environmentally harmful chemical substances, relays with cadmium-free contacts are used.

#### 4. Economically priced

- 1) Prices set to lower costs.
- 2) Further cost reduction when used with HJ Relay terminal socket.

#### 5. CE marking supported

UL and C-UL approved.



## PRODUCT TYPES

### 1. S1DXM-A multi-range timer

No MODE switch, Operation mode (fixed): Power ON-delay

Operating voltage	Time range	Timed-out 2 Form C	Timed-out 4 Form C
		Part number	Part number
12V DC	0.05 s to 10 min	S1DXM-A2C10M-DC12V	S1DXM-A4C10M-DC12V
	0.2 s to 30 min	S1DXM-A2C30M-DC12V	S1DXM-A4C30M-DC12V
	0.5 s to 60 min	S1DXM-A2C60M-DC12V	S1DXM-A4C60M-DC12V
	0.05 min to 10 hr	S1DXM-A2C10H-DC12V	S1DXM-A4C10H-DC12V
24V DC	0.05 s to 10 min	S1DXM-A2C10M-DC24V	S1DXM-A4C10M-DC24V
	0.2 s to 30 min	S1DXM-A2C30M-DC24V	S1DXM-A4C30M-DC24V
	0.5 s to 60 min	S1DXM-A2C60M-DC24V	S1DXM-A4C60M-DC24V
	0.05 min to 10 hr	S1DXM-A2C10H-DC24V	S1DXM-A4C10H-DC24V
24V AC	0.05 s to 10 min	S1DXM-A2C10M-AC24V	S1DXM-A4C10M-AC24V
	0.2 s to 30 min	S1DXM-A2C30M-AC24V	S1DXM-A4C30M-AC24V
	0.5 s to 60 min	S1DXM-A2C60M-AC24V	S1DXM-A4C60M-AC24V
	0.05 min to 10 hr	S1DXM-A2C10H-AC24V	S1DXM-A4C10H-AC24V
100 to 120V AC	0.05 s to 10 min	S1DXM-A2C10M-AC120V	S1DXM-A4C10M-AC120V
	0.2 s to 30 min	S1DXM-A2C30M-AC120V	S1DXM-A4C30M-AC120V
	0.5 s to 60 min	S1DXM-A2C60M-AC120V	S1DXM-A4C60M-AC120V
	0.05 min to 10 hr	S1DXM-A2C10H-AC120V	S1DXM-A4C10H-AC120V
200 to 220V AC	0.05 s to 10 min	S1DXM-A2C10M-AC220V	S1DXM-A4C10M-AC220V
	0.2 s to 30 min	S1DXM-A2C30M-AC220V	S1DXM-A4C30M-AC220V
	0.5 s to 60 min	S1DXM-A2C60M-AC220V	S1DXM-A4C60M-AC220V
	0.05 min to 10 hr	S1DXM-A2C10H-AC220V	S1DXM-A4C10H-AC220V
220 to 240V AC	0.05 s to 10 min	S1DXM-A2C10M-AC240V	S1DXM-A4C10M-AC240V
	0.2 s to 30 min	S1DXM-A2C30M-AC240V	S1DXM-A4C30M-AC240V
	0.5 s to 60 min	S1DXM-A2C60M-AC240V	S1DXM-A4C60M-AC240V
	0.05 min to 10 hr	S1DXM-A2C10H-AC240V	S1DXM-A4C10H-AC240V

# S1DXM-A/M

## 2. S1DXM-M multi-range timer

With MODE switch, Operation mode (switchable): Power ON-delay, Power Flicker ON start, Power Flicker OFF start, Power One-shot

Operating voltage	Time range	Timed-out 2 Form C	Timed-out 4 Form C
		Part number	Part number
12V DC	0.05 s to 10 min	S1DXM-M2C10M-DC12V	S1DXM-M4C10M-DC12V
	0.2 s to 30 min	S1DXM-M2C30M-DC12V	S1DXM-M4C30M-DC12V
	0.5 s to 60 min	S1DXM-M2C60M-DC12V	S1DXM-M4C60M-DC12V
	0.05 min to 10 hr	S1DXM-M2C10H-DC12V	S1DXM-M4C10H-DC12V
24V DC	0.05 s to 10 min	S1DXM-M2C10M-DC24V	S1DXM-M4C10M-DC24V
	0.2 s to 30 min	S1DXM-M2C30M-DC24V	S1DXM-M4C30M-DC24V
	0.5 s to 60 min	S1DXM-M2C60M-DC24V	S1DXM-M4C60M-DC24V
	0.05 min to 10 hr	S1DXM-M2C10H-DC24V	S1DXM-M4C10H-DC24V
24V AC	0.05 s to 10 min	S1DXM-M2C10M-AC24V	S1DXM-M4C10M-AC24V
	0.2 s to 30 min	S1DXM-M2C30M-AC24V	S1DXM-M4C30M-AC24V
	0.5 s to 60 min	S1DXM-M2C60M-AC24V	S1DXM-M4C60M-AC24V
	0.05 min to 10 hr	S1DXM-M2C10H-AC24V	S1DXM-M4C10H-AC24V
100 to 120V AC	0.05 s to 10 min	S1DXM-M2C10M-AC120V	S1DXM-M4C10M-AC120V
	0.2 s to 30 min	S1DXM-M2C30M-AC120V	S1DXM-M4C30M-AC120V
	0.5 s to 60 min	S1DXM-M2C60M-AC120V	S1DXM-M4C60M-AC120V
	0.05 min to 10 hr	S1DXM-M2C10H-AC120V	S1DXM-M4C10H-AC120V
200 to 220V AC	0.05 s to 10 min	S1DXM-M2C10M-AC220V	S1DXM-M4C10M-AC220V
	0.2 s to 30 min	S1DXM-M2C30M-AC220V	S1DXM-M4C30M-AC220V
	0.5 s to 60 min	S1DXM-M2C60M-AC220V	S1DXM-M4C60M-AC220V
	0.05 min to 10 hr	S1DXM-M2C10H-AC220V	S1DXM-M4C10H-AC220V
220 to 240V AC	0.05 s to 10 min	S1DXM-M2C10M-AC240V	S1DXM-M4C10M-AC240V
	0.2 s to 30 min	S1DXM-M2C30M-AC240V	S1DXM-M4C30M-AC240V
	0.5 s to 60 min	S1DXM-M2C60M-AC240V	S1DXM-M4C60M-AC240V
	0.05 min to 10 hr	S1DXM-M2C10H-AC240V	S1DXM-M4C10H-AC240V

## PART NAMES

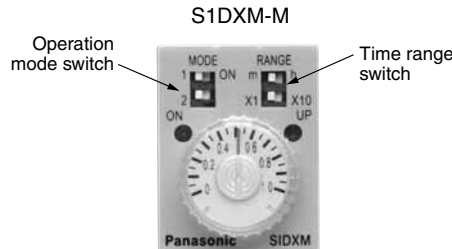
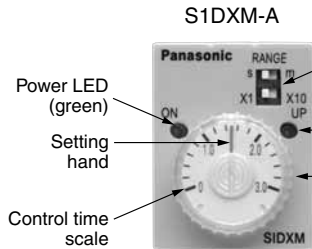

- [RANGE] Time range switch (4 different time ranges can be switched.)  
 10M type: 1 s/10 s/1 min/10 min  
 30M type: 3 s/30 s/3 min/30 min  
 60M type: 6 s/60 s/6 min/60 min  
 10H type: 1 min/10 min/1 hr/10 hr
- [MODE] Operation mode switch (4 different operation modes can be switched.)  
 Power ON-delay  
 Power Flicker OFF start  
 Power Flicker ON start  
 Power One-shot

## OPERATION MODE AND TIME RANGE SETTING

Operation mode	Operation mode switch
Power ON-delay	1  ON 2
Power Flicker OFF start	1  ON 2
Power Flicker ON start	1  ON 2
Power One-shot	1  ON 2

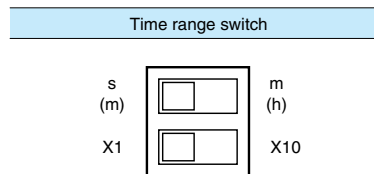

The time setting can be switched among 4 ranges each for 4 types for an interval between 0.05 seconds and 10 hours.

- Notes:
1. The product is factory shipped with all settings on the OFF side (left).
  2. Do not operate the switches with a sharp-edged object such as a knife blade.
  3. The power must be turned off when setting the time range or operation mode. Operating the switches with the power on is a cause of breakdown and malfunction.
  4. Use a force of under 5 N to operate the DIP switches when setting the time range and operation mode.

## OPERATION MODE

### 1. S1DXM-A multi-range timer

#### Power ON-delay operation

- When power is turned on, the output contact operates after the set time. The output contact remains on until the power is turned off.

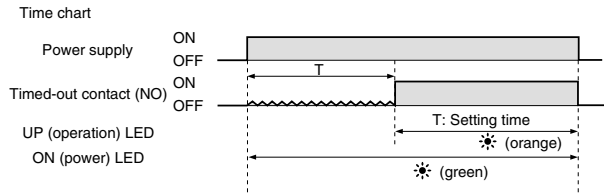

### 2. S1DXM-M multi-range timer

#### Power ON-delay operation

[MODE] switch 1: OFF, switch 2: OFF

- When power is turned on, the output contact operates after the set time. The output contact remains on until the power is turned off.

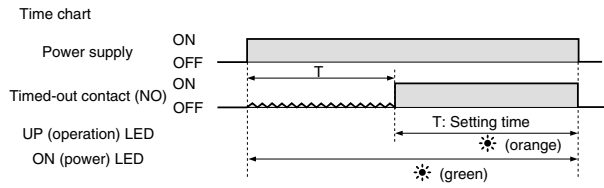

#### Power Flicker OFF start operation

[MODE] switch 1: OFF, switch 2: ON

- When the power is turned on, the output contacts repeatedly operate at the set time. The output contact begins from the off state.

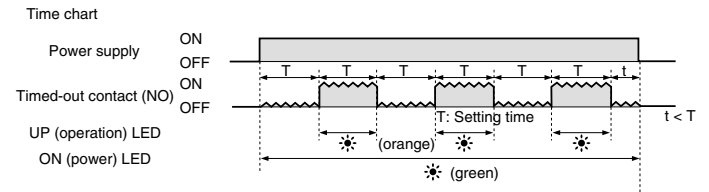

#### Power Flicker ON start operation

[MODE] switch 1: ON, switch 2: OFF

- When power is turned on, the output contact operates repeatedly at the set time. The output contact outputs at the same time power turns on.

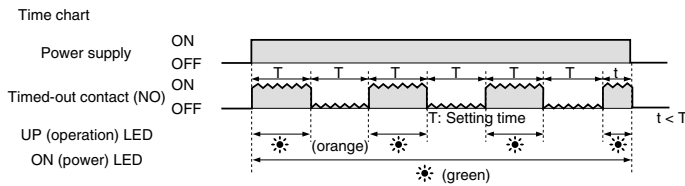

#### Power One-shot operation

[MODE] switch 1: ON, switch 2: ON

- When power is turned on, the output contact performs the on operation at the same time power turns on, only for the set time.

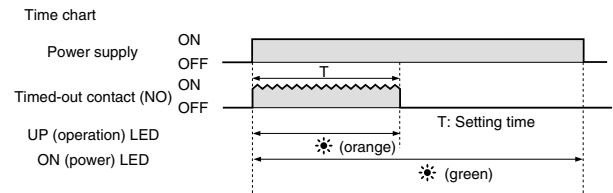

## TIME RANGE SETTING

Type		Time scale		Time unit		Min. scale	Max. scale	Setting range			
S1DXM-A	10M type	X1	X10	s	m	0.05	1	0.05 to 1s	0.5 to 10s	0.05 to 1m	0.5 to 10m
	30M type			s	m	0.2	3	0.2 to 3s	2 to 30s	0.2 to 3m	2 to 30m
	60M type			s	m	0.5	6	0.5 to 6s	5 to 60s	0.5 to 6m	5 to 60m
	10H type			m	h	0.05	1	0.05 to 1m	0.5 to 10m	0.05 to 1h	0.5 to 10h
S1DXM-M	10M type	X1	X10	s	m	0.05	1	0.05 to 1s	0.5 to 10s	0.05 to 1m	0.5 to 10m
	30M type			s	m	0.2	3	0.2 to 3s	2 to 30s	0.2 to 3m	2 to 30m
	60M type			s	m	0.5	6	0.5 to 6s	5 to 60s	0.5 to 6m	5 to 60m
	10H type			m	h	0.05	1	0.05 to 1m	0.5 to 10m	0.05 to 1h	0.5 to 10h

Note: The time setting range is the combination of the time scale (X1 or X10) on the dial and the time unit (s, m, or h).

Example: When dial reads 1, time scale is X1 and time units is seconds, then it is 1 second.

## ORDERING INFORMATION

Ex. S1DXM- **A** **2C** **30M** - **DC24V**

Operation mode	Control output arrangement	Time range	Operating voltage*
A M	2C: Timed-out 2 Form C 4C: Timed-out 4 Form C	10M: 0.05 s to 10 min 30M: 0.2 s to 30 min 60M: 0.5 s to 60 min 10H: 0.05 min to 10 hr	DC12V: 12 V DC DC24V: 24 V DC AC24V: 24 V AC AC120V: 100 to 120 V AC AC220V: 200 to 220 V AC AC240V: 220 to 240 V AC

\* For other operating voltage types, please consult us.

# S1DXM-A/M

## SPECIFICATIONS

Item		Specifications						
Rating	Rated operating voltage	24VAC	100 to 120VAC	200 to 220VAC	220 to 240VAC	12VDC	24VDC	
	Rated frequency	50/60Hz common						
	Rated power consumption		Max. 3 VA (at 24 VAC)	Max. 3 VA (at 100 VAC)	Max. 3 VA (at 200 VAC)	Max. 3 VA (at 220 VAC)	Max. 2 W (at 12 VDC)	Max. 2 W (at 24 VDC)
		During time delay	Approx. 3mA	Approx. 3mA	Approx. 3mA	Approx. 3mA	Approx. 5mA	Approx. 3mA
	After time delay	Approx. 80mA	Approx. 20mA	Approx. 13mA	Approx. 13mA	Approx. 70mA	Approx. 40mA	
	Rated control capacity	Timed -out 2 Form C: 7A 250V AC (resistive load) Timed -out 4 Form C: 5A 250V AC (resistive load)						
Operation mode	S1DXM-A Power on delay operation fixed (Power display: ON/green; Operation display (when output is on): UP/orange)  S1DXM-M 4 switchable operations: Power ON-delay/Power Flicker OFF start/Power Flicker ON start/Power One-shot (Power display: ON/green; Operation display (when output is on): UP/orange)							
Time accuracy*1	Operating time fluctuation & Power off time change error	Max. ±1 %, (power off time change at the range of 0.1 s to 1 h), 1 s range: Max. ±1 % and 10 ms*3						
	Voltage error	Max. ±1 % (at the operating voltage changes between -20 to +10%), 1 s range: Max. ±1 % and 10 ms*3						
	Temperature error	Max. ±5% (at 20°C ambient temp. at the range of -10 to +50°C +14 to +122°F)						
	Setting error	Max. ±10%, 1 s range: Max. ±10% and 20 ms						
Contact	Contact arrangement	Timed-out 2 Form C, Timed-out 4 Form C						
	Contact resistance (Initial value)	Max. 100mΩ (at 1A, 6V DC)						
	Contact material	Timed-out 2 Form C type: Silver alloy, Au plating Timed-out 4 Form C type: Silver alloy, Au plating						
Life	Mechanical (constant)	Min. 10 <sup>7</sup>						
	Electrical (constant)	2×10 <sup>5</sup> (at rated control capacity)						
Mechanical	Vibration resistance	Functional	10 to 55Hz: 1 cycle/min double amplitude of 0.25mm (10min on 3 axes)					
		Destructive	10 to 55Hz: 1 cycle/min double amplitude of 0.375mm (1h on 3 axes)					
	Shock resistance	Functional	Min. 98m/s <sup>2</sup> (4 times on 3 axes)					
		Destructive	Min. 980m/s <sup>2</sup> (5 times on 3 axes)					
Electrical	Allowable operating voltage range	80 to 110% of rated operating voltage						
	Reset time	Max. 0.1s						
	Insulation resistance (Initial value)	Between live and dead metal parts, between input and output, between contact sets, between contacts Min. 100 MΩ (at 500 V DC megger)						
	Breakdown voltage (Initial value)	Between live and dead metal parts: 1,500 Vrms for 1 min Between input and output: 1,500 Vrms for 1 min Between contact sets: 1,500 Vrms for 1 min Between contacts: 1,000 Vrms for 1 min						
	Max. temperature rise	70°C 158°F						
Operating conditions	Ambient temperature	-10 to 50°C +14 to 122°F						
	Ambient humidity	35 to 85% RH (non-condensing)						
	Air pressure	860 to 1060 hPa						
	Ripple rate	DC type only, transmission wave rectification (ripple rate: approx. 48%)*2						
	Mass (Weight)	Approx. 45 g						
	Protective construction	IEC standard: IP40 (IP50 when using ADX18008 protective cover)						

Notes: \*1. Unspecified measuring conditions are rated operating voltage (in case of DC type, ripple rate of 5% or less), ambient temp. 20°C 68°F, and power off time 1 second.

\*2. When using with a transmission wave rectification, vibration resistance and shock resistance properties worsen compared to when using a stabilized power supply.

\*3. Power one-shot 1 s range: +2% and 10 ms

**DIMENSIONS**

**1. S1DXM-A**

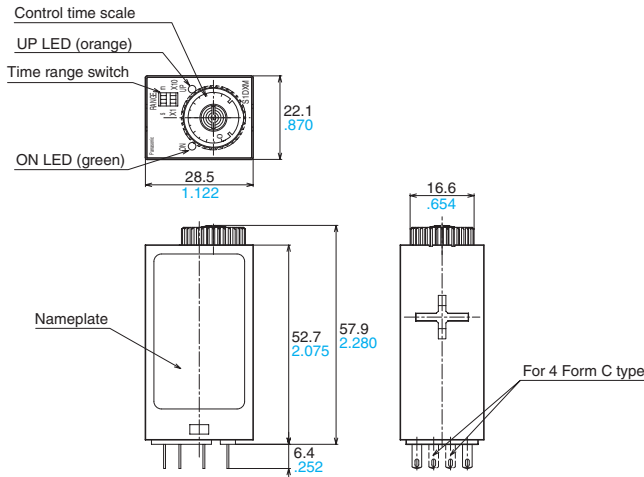

Tolerance:  $\pm 05 \pm .020$

**Terminal layouts and Wiring diagram**  
Timed-out 2 Form C type

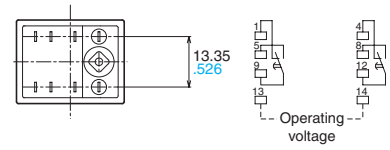

Timed-out 4 Form C type

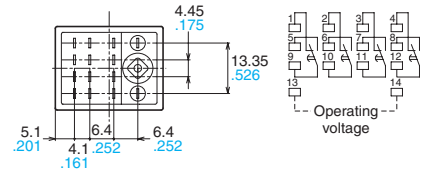

\* For the DC operating type, terminal 14 is "+" and terminal 13 is "-".

**2. S1DXM-M**

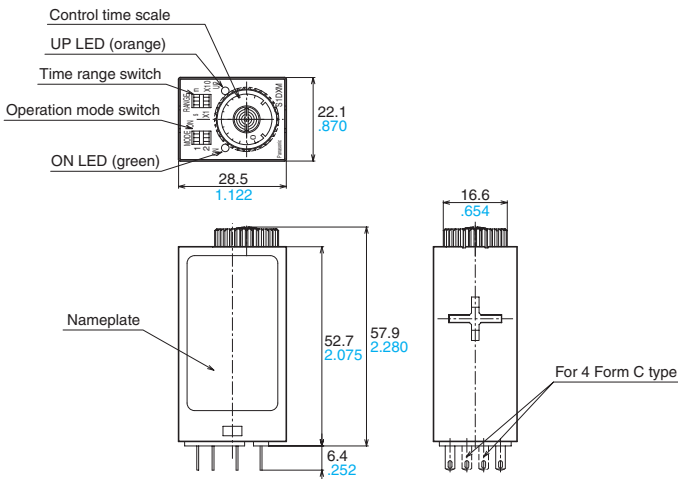

Tolerance:  $\pm 05 \pm .020$

**Terminal layouts and Wiring diagram**  
Timed-out 2 Form C type

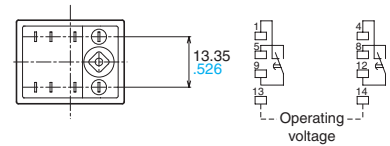

Timed-out 4 Form C type

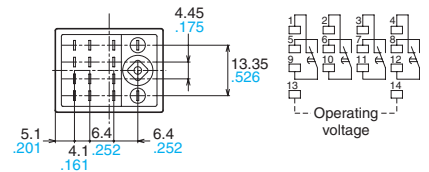

\* For the DC operating type, terminal 14 is "+" and terminal 13 is "-".

**APPLICABLE STANDARD**

Safety standard	EN61812-1	Pollution Degree 2/Overvoltage Category II (2 Form C type); Pollution Degree 1/Overvoltage Category II (4 Form C type)
EMC	(EMI)EN61000-4-4 Radiation interference electric field strength	EN55011 Group1 ClassA
	Noise terminal voltage	EN55011 Group1 ClassA
	(EMS)EN61000-6-2 Static discharge immunity	EN61000-4-2 4 kV contact (level 2) 8 kV air (level 2)
	RF electromagnetic field immunity	EN61000-4-3 10 V/m AM modulation (80 MHz to 1 GHz) (level 3) 10 V/m pulse modulation (895 MHz to 905 MHz) level 3)
	EFT/B immunity	EN61000-4-4 2 kV (power supply line) (level 3) 1 kV (signal line) (level 3)
	Surge immunity	EN61000-4-5 1 kV (power line) (level 2)
	Conductivity noise immunity	EN61000-4-6 10 V/m AM modulation (0.15 MHz to 80 MHz) (level 3)
Power frequency magnetic field immunity	EN61000-4-8 30 A/m (50 Hz) (level 4)	
Voltage dip/Instantaneous stop/Voltage fluctuation immunity	EN61000-4-11 10 ms, 30% (rated voltage) 100 ms, 60% (rated voltage) 1,000 ms, 60% (rated voltage) 5,000 ms, 95% (rated voltage)	

# S1DXM-A/M

## ACCESSORY Note: Accessories are the same as those for the S1DX timer.

- Mounting frame for S1DX/S1DXM



ADX18002 (Titanium-gray)  
ADX18006 (Gray)  
ADX18007 (Black)

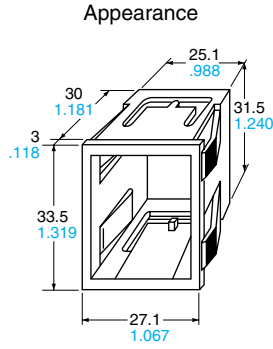

### Panel cutout dimensions

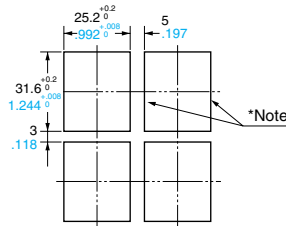

Board thickness 1 to 3 mm  
Note: Make sure the holes area stays as right angles.

- Protective cover

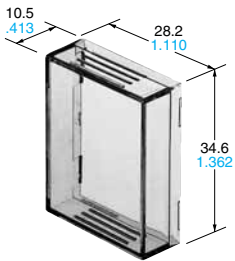

ADX18008

- Cap block for S1DX/S1DXM

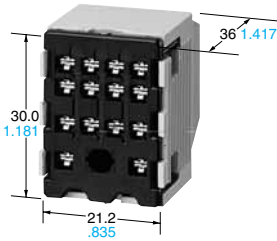

ADX18011

- Cap



ADX18004

- Socket

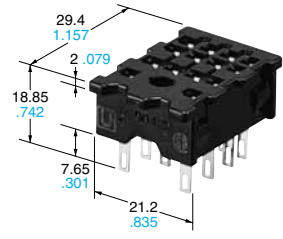

ADX18003

## TERMINAL SOCKET

- HC2 slim DIN terminal socket

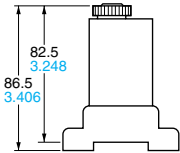

HC2-SFD-S

- HC2 DIN high terminal socket

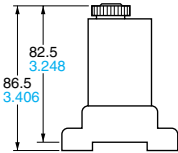

HC2-SFD-K

- HC4 DIN high terminal socket

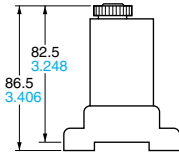

HC4-SFD-K

- HC4 socket

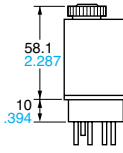

HC4-SS-K

- HJ2 terminal socket

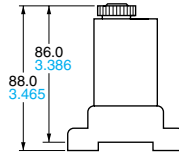

HJ2-SFD/HJ2-SFD-S

- HJ4 terminal socket

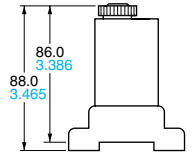

HJ4-SFD/HJ4-SFD-S

## SOCKET LEAF HOLDING CLIP FOR S1DX/S1DXM

ADX18001		ADX18012		AD68002	
Figure	Dimensions	Figure	Dimensions	Figure	Dimensions
	4.5 (.177), 63.1 (2.484)		4.5 (.177), 61.6 (2.425)		63.8 (2.512), 4.5 (.177)
(2 pieces per set)		(2 pieces per set)		(2 pieces per set)	

## SOCKET LINE HOLDING CLIP FOR S1DXM

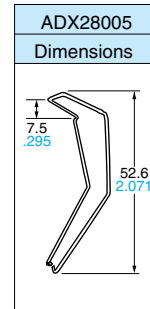

Terminal socket	Type	Application			
		ADX18001	ADX18012	AD68002	ADX28005
For HC relay	HC2-SFD-S	—	—	○	○
	HC2-SFD-K	○	—	△	○
	HC4-SFD-K	○	—	△	○
For HJ relay	HJ2-SFD	—	○	—	—
	HJ2-SFD-S	—	○	—	—
	HJ4-SFD	—	△	—	—
	HJ4-SFD-S	—	△	—	—

Note: The triangles indicate that removal will be slightly difficult when installed laterally in succession.

## S1DX and S1DXM-A/M TIMER OPTIONS

For shared optional parts, please refer to "Timer/Timer Switches/Counters/Hour Meters Group Catalog" (ARCT1B232E).

## Precautions during usage

### 1. Reset periods

After unscheduled operations have been completed, or if the timer operation power supply has been turned off at any time during operation, a reset period of at least 0.1 seconds should be allowed before resuming operation.

### 2. External surge protection

External surge protection may be required if the following values are exceeded. Otherwise, the internal circuit will be damaged. The typical surge absorption elements include a varistor, a capacitor, and a diode. If a surge absorption element is used, use an oscilloscope to see whether or not the foreign surge exceeding the specified value appears.

#### • Single-pole, full-wave voltage for surge waveform [ $\pm(1.2 \times 50) \mu\text{s}$ ]

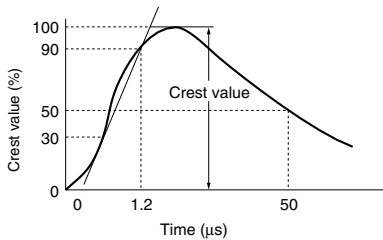

Operation voltage	Surge voltage
100 to 120V AC, 200 to 220V AC	4,000V
12V DC, 24V DC	1,000V

Since the main body cover and knob are made of polycarbonate resin, prevent contact with organic solvents such as methyl alcohol, benzene and thinner, or strong alkali materials such as ammonia and caustic soda.

### 3. Terminal wiring

Make sure that terminals are wired carefully and correctly, referring to the terminal layout and wiring diagrams. Particularly, since the DC type has polarity, do not operate it with reverse polarity.

### 4. Assembly

- 1) When installing, use a terminal socket or socket intended for the HC/HJ relay. For adjacent installations, be sure to first verify the installation conditions of the terminal sockets or sockets you will be using.
- 2) Use the separately-sold dedicated socket leaf holding clip to secure terminal sockets and sockets to the timer unit. The conditions of use for dedicated socket leaf holding clip will differ depending on the terminal socket or socket you will be using. Therefore, please test under actual conditions before putting into operation.
- 3) If terminals are to be soldered directly,

please hand solder with a 30 to 60 W solder iron with a tip temperature of 300°C for no more than 3 seconds. Automatic soldering should be avoided.

4) A flux-tight construction is not used with this timer, so be careful that flux or cleaning fluid does not get inside the case.

5) To assure that characteristics are maintained, do not remove the case.

### 5. Long Continuous Current Flow

Long continuous current flow through the timer cause generation of heat internally, which degrade the electronic parts. Use the timer in combination with a relay and avoid long continuous current flow through the timer. (Refer to the circuit diagram below when using a safety circuit for continuous operation.)

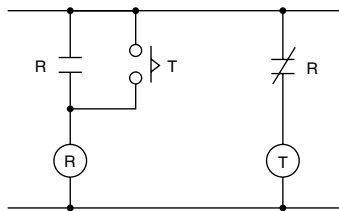

### 6. Phase synchronization using AC load

If the turning on of the timer output relay is synchronized to the AC power supply phase, there may be times when the service life is shortened because of electrical factors, or when a locking phenomenon (defective relay return) occurs because of contact point welding or a shift in the contact relay. Check the operation using the actual timer.

### 7. Acquisition of CE marking

Please abide by the conditions below when using in applications that comply with EN61812-1.

- 1) Overvoltage category II, pollution level 2 (2 Form C type)  
Overvoltage category II, pollution level 1 (4 Form C type)
- 2) The load connected to the output contact should have basic insulation. This timer is protected with basic insulation and can be double-insulated to meet EN/IEC requirements by using basic insulation on the load.
- 3) Please use a power supply that is protected by an overcurrent protection device which complies with the EN/IEC standard (example: 250 V 1 A fuse, etc.).
- 4) You must use a terminal socket or socket for the installation. Do not touch the terminals or other parts of the timer when it is powered. When installing or un-installing, make sure that no voltage is being applied to any of the terminals.

5) Do not use this timer as a safety circuit. For example when using a timer in a heater circuit, etc., provide a protection circuit on the machine side.

### 8. Others

- 1) When setting the time, the dial should be kept within the range indicated on the dial face. The "0" marking on the dial indicates the minimum time during which the control time can be varied (it does not indicate 0 seconds).
- 2) Do not rotate the knob past the stopper.
- 3) Turn off the power before changing the DIP switch settings. Changing the DIP switch with the power on can cause breakdown.
- 4) When connecting the operating power supply, make sure that no leakage current enters the timer. For example, when performing contact protection, if set up like that of fig. A, leaking current will pass through C and R, enter the timer, and cause incorrect operation. The fig. B shows the correct setup.

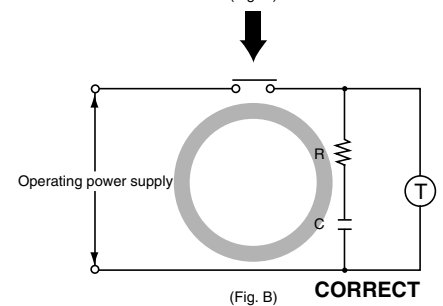
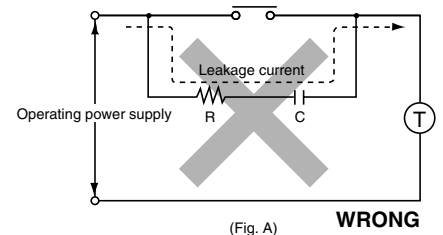

When a contact switch having an operation indicating lamp (lamp equipped limit switch, etc.) is used to apply power to the timer, a resistor having a value equal to or greater than the value below shall be connected in series with the lamp.

100 to 120V AC operating type:

Min. 33kΩ

200 to 220V AC operating type:

Min. 82kΩ

