

ISL85003DEMO1Z, ISL85003ADEMO1Z Evaluation Board User Guide

Description

The ISL85003 and ISL85003A Demo kits are intended for use for point-of-load applications sourcing from 4.5V to 18V. The kits are used to demonstrate the performance of the ISL85003 and ISL85003A, high efficiency synchronous buck regulators. The ISL85003 and ISL85003A are offered in a 4x3mm dual flat no lead (DFN) package.

Recommended Equipment

The following materials are recommended to perform testing:

- 0V to 25V power supply with at least 10A source current capability
- Electronic loads capable of sinking current up to 7A
- Digital Multimeters (DMMs)
- 100MHz quad-trace oscilloscope

Key Features

- Input voltage range 4.5V to 18V
- Current mode control
 - DCM/PWM
 - Internal or external compensation options
 - 500kHz switching frequency option
 - External synchronization up to 2MHz on ISL85003
- Adjustable soft-start time on the ISL85003A
- Continuous output current up to 3A
- Minimal external components required

References

[ISL85003, ISL85003A Datasheet](#)

Ordering Information

PART NUMBER	DESCRIPTION
ISL85003DEMO1Z	Small form factor Demo board for 3A, 4.5V to 18V Switching Regulator, external synchronization.
ISL85003ADEMO1Z	Small form factor Demo board for 3A, 4.5V to 18V Switching Regulator, adjustable soft-start time

Quick Setup Guide

1. Ensure that the circuit is correctly connected to the supply and loads prior to applying any power.
2. Connect the bias supply to VIN, the plus terminal to VIN and the negative return to PGND.
3. Turn on the power supply.
4. Verify the output voltage is 5V for V_{OUT}.

Evaluating the Other Output Voltage

The ISL85003DEMO1Z kit output is preset to 5V; however, output voltages are programmed using an external resistor divider that scales the feedback relative to the internal reference voltage. Please refer to the application note [AN1930](#) and the [ISL85003, ISL85003A](#) datasheet for further information.

Disabling/Enabling Function

The ISL85003DEMO1Z board has EN pin tied to VIN via R₇. This keeps the part enabled all the time. To disable the part, remove R₇.

MODE/SS Control

The ISL85003 evaluation board has a MODE pin that allows different mode operation. Default board configuration has R₆ = 200k to V_{CC}, which defaults to PWM operation mode. If this pin is tied to GND the IC will operate in CCM mode.

The ISL85003A evaluation board has an SS pin that provides a programmable soft-start. When the chip is enabled, the regulated 4µA pull-up current source charges a capacitor C₁₀ connected from SS to ground. Default board configuration has R₆ = 200k to V_{CC}, which defaults to internal SS.

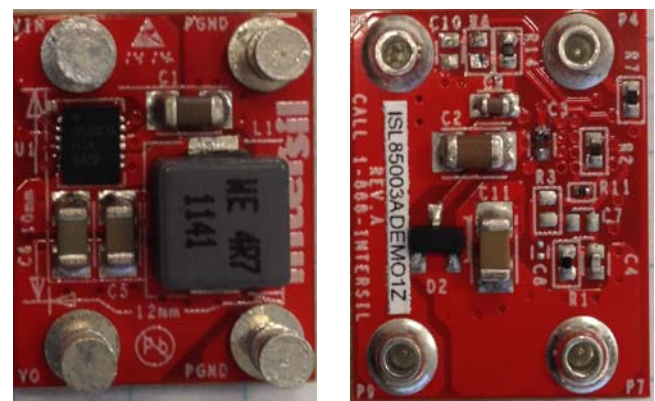

TOP SIDE

BOTTOM SIDE

FIGURE 1. ISL85003ADEMO1Z PICTURES

ISL85003ADEM01Z Board Layout

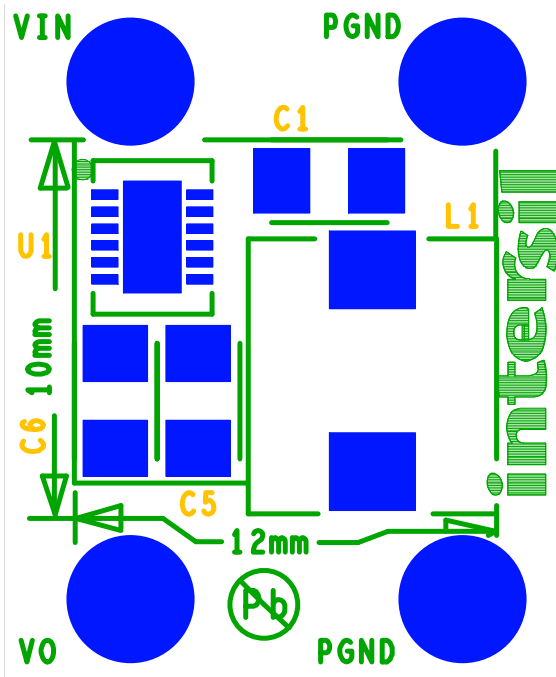

FIGURE 2. SILK SCREEN TOP

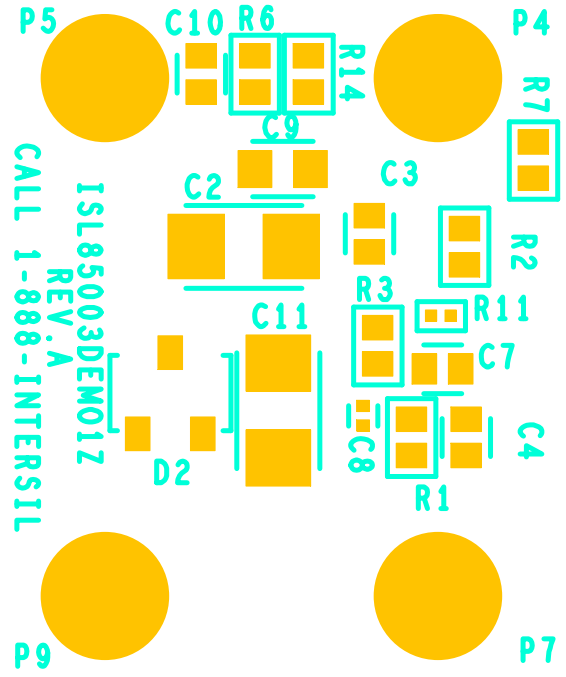
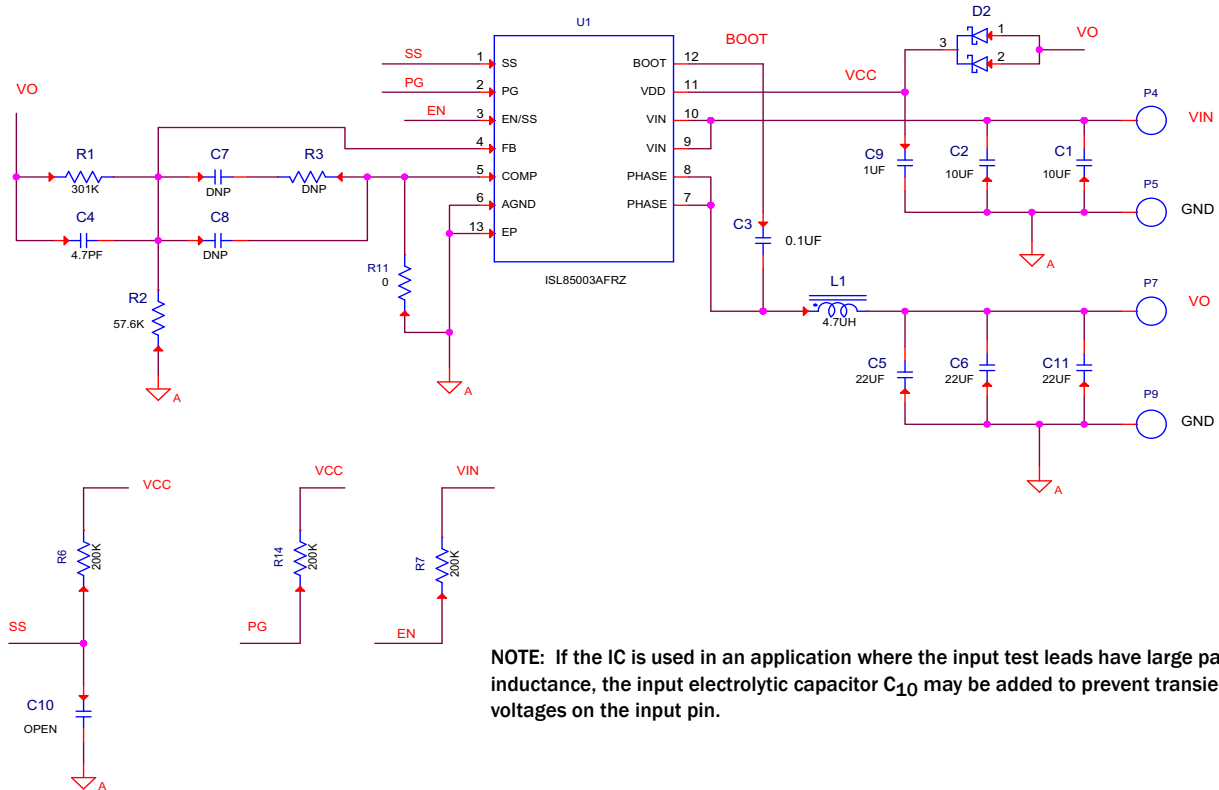

FIGURE 3. SILK SCREEN BOTTOM

ISL85003ADEM01Z Schematic



Application Note 1935

ISL85003DEMO1Z, ISL85003ADEMO1Z Bill of Materials

PART NUMBER	QTY	UNIT S	REFERENCE DESIGNATOR	DESCRIPTION	MANUFACTURER	MANUFACTURER PART
ISL85003FRZ	1	ea.	U1	IC-3A BUCK REGULATOR, 12P, DFN, 4X3, ROHS	INTERSIL	ISL85003FRZ
ISL85003AFRZ	1	ea.	U1	IC-3A BUCK REGULATOR PWM, 12P, DFN, 4X3, ROHS	INTERSIL	ISL85003AFRZ
H1044-00104-50V10-T	1	ea.	C3	CAP, SMD, 0402, 0.1 μ F, 50V, 10%, X7R, ROHS	TDK	C1005X7R1H104K
H1044-004R7-50VR25-T	1	ea.	C4	CAP, SMD, 0402, 4.7PF, 50V, 0.25pF, NPO, ROHS	AVX	04025A4R7CAT2A
H1044-DNP	0	ea.	C7, C10	CAP, SMD, 0402, DNP-PLACE HOLDER, ROHS		
H1045-00105-16V10-T	1	ea.	C9	CAP, SMD, 0603, 1 μ F, 16V, 10%, X5R, ROHS	MURATA	GRM188R61C105KA12D
H1065-00106-25V10-T	2	ea.	C1, C2	CAP, SMD, 1206, 10 μ F, 25V, 10%, X7R, ROHS	VENKEL	C1206X7R250-106KNE
H1065-00226-16V10-T	3	ea.	C5, C6, C11	CAP, SMD, 1206, 22 μ F, 16V, 10%, X5R, ROHS	VENKEL	C1206X5R160-226KNE
744311470	1	ea.	L1	COIL-PWR CHOKE, SMD, 7X6.9, 4.7 μ H, 20%, 6A, 19.5m Ω , ROHS	WURTH ELECTRONICS MIDCOM INC.	744311470
BAT54C-T	1	ea.	D2	DIODE-RECTIFIER, SMD, SOT23, 3P, 30V, 200mA, ROHS	FAIRCHILD	BAT54C
H2510-00R00-1/16W-T	1	ea.	R11	RES, SMD, 0402, 0 Ω , 1/16W, 5%, TF, ROHS	VENKEL	CR0402-16W-00T
H2510-02003-1/16W1-T	3	ea.	R6, R7, R14	RES, SMD, 0402, 200k, 1/16W, 1%, TF, ROHS	ROHM	MCR01MZPF2003
H2510-03013-1/16W1-T	1	ea.	R1	RES, SMD, 0402, 301k, 1/16W, 1%, TF, ROHS	YAGEO	RC0402FR-07301KL
H2510-05762-1/16W1-T	1	ea.	R2	RES, SMD, 0402, 57.6k, 1/16W, 1%, TF, ROHS	PANASONIC	ERJ-2RKF5762X

Intersil Corporation reserves the right to make changes in circuit design, software and/or specifications at any time without notice. Accordingly, the reader is cautioned to verify that the Application Note or Technical Brief is current before proceeding.

For information regarding Intersil Corporation and its products, see www.intersil.com