

DCmind: DC DIRECT-DRIVE BRUSH MOTORS

Ø 63 mm - 102 W

- › Silent motor
- › 12 V and 24 V built in EMC filter class B
- › Excellent efficiency
- › Long life
- › IP65
- › In accordance with UL - CE - ROHS regulations



Part numbers

	12 V	24 V	48 V	90 V
Type	89830	89830	89830	89830
Voltage	12 V ^{DC}	24 V ^{DC}	48 V ^{DC}	90 V ^{DC}
References				
Option: IP65 level	89830011	89830012	89830003	89830004
Option: holding brake 0.5 Nm, 24 V ^{DC}	89830511	89830512	89830503	89830504
Option: 2 channels encoder 1000 pulses/revolution, 5 V ^{DC}	89830911	89830912	89830903	89830904
No-load characteristics				
Speed (rpm)	3830	3600	3550	3550
Absorbed current (A)	0.52	0.23	0.14	0.07
Nominal characteristics				
Speed (rpm)	2850	3000	3050	3000
Torque (mNm)	180	180	180	180
Output power (W)	54	57	57	57
Absorbed current (A)	6.5	3.1	1.54	0.83
Efficiency (%)	69	77	78	76
Maximum efficiency characteristics				
Speed (rpm)	3340	3240	3200	3200
Torque (mNm)	90	111	131	128
Output power (W)	31	38	44	43
Absorbed current (A)	3.5	1.97	1.15	0.61
Efficiency (%)	75	80	80	78
General characteristics				
Insulation conforming to IEC 60085	Class E	Class E	Class E	Class E
Noise level (dBA)	35	35	35	35
Max. output power (W)	70	102	114	109
Starting torque (mNm)	703	1080	1230	1177
Starting current (A)	24	17.2	9.7	5
Resistance (Ω)	0.5	1.4	4.9	18
Inductance (mH)	0.38	1.7	7	25
Torque constant (mNm/A)	30	64	129	237
Electrical time constant (ms)	0.8	1.2	1.4	1.4
Mechanical time constant (ms)	21	13	11	12
Inertia (g.cm ²)	380	380	380	380
Weight (g)	1200	1200	1200	1200
Commutator segments	12	12	12	12
Service life (h)	5000	5000	5000	5000
Wires length (mm)	200	200	200	200
Ball bearing	✓	✓	✓	✓
Comments				
IP65 level except for the output shaft. Encoder and brake options are IP20.				

Product adaptations, contact us



- › Special output shaft
- › Shaft with pinion, pulley, worm gear
- › Special supply voltage
- › Other wire length
- › Optical or Hall effect encoder - 1 or 2 channels
- › Specific motor mounting flange
- › Special motor connectors
- › IP67, IP69K

 Product made to order

Curves

89830011 - 89830511 - 89830911

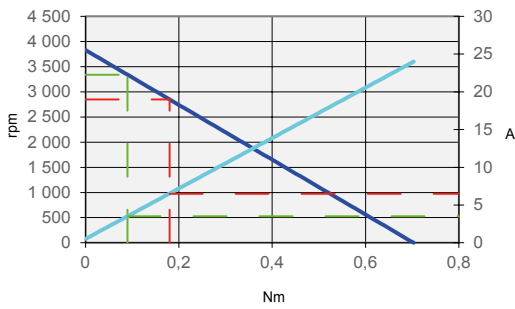

89830012 - 89830512 - 89830912

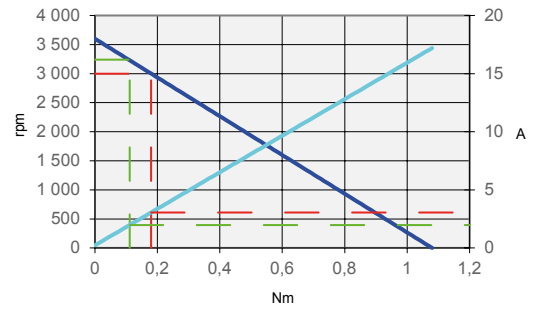

89830003 - 89830503 - 89830903

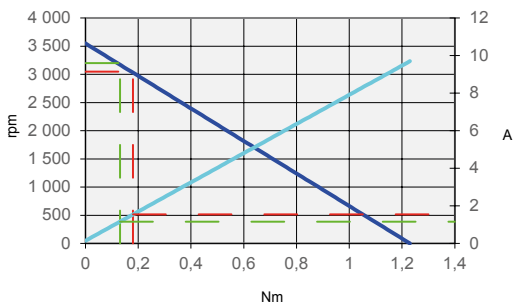

89830004 - 89830504 - 89830904

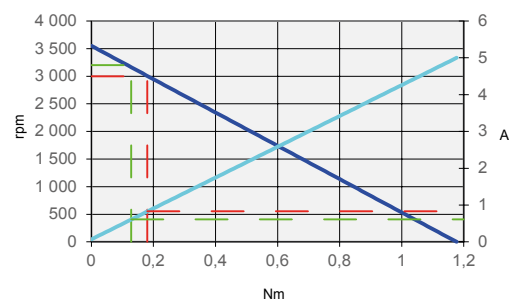

- Speed (rpm)
- Current (A)
- Torque at nominal
- Torque at maximum efficiency

Dimensions (mm)

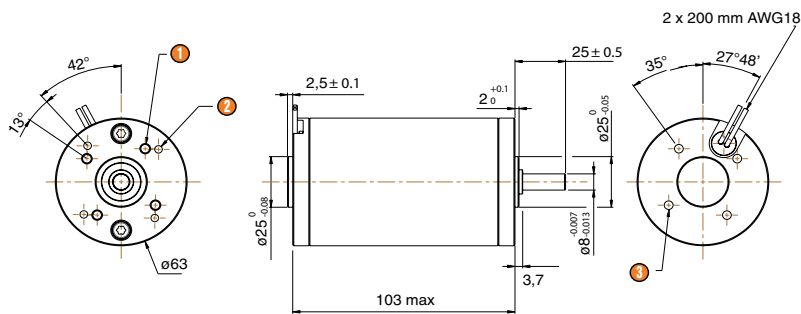

- ① 4 x M5 at 90° depth 10 over Ø 40
- ② 4 x Ø 3.65 at 90° depth 8 over Ø 48
- ③ 4 x M5 at 90° depth 7 over Ø 40

Options

Holding brake 0.5 Nm

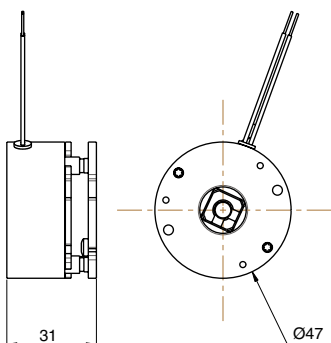

Encoder

