

OK Industries. Connecting Technologies.



PAGE 4-7

FIBRE OPTIC CABLE
STRIPPING TOOLS



PAGE 8

WIRE WRAPPING
OVERVIEW



PAGE 9

PTX SERIES
WRAP/UNWRAP TOOLS



PAGE 10

MANUAL WIRE WRAP/
UNWRAP TOOLS



PAGE 11

BIT & SLEEVE CHART



PAGE 12

SPECIALISED
BITS/SLEEVES



PAGE 13

DFB224 DUAL FUNCTION
WRAP/UNWRAP BIT & SLEEVE SET



PAGE 14

HAND WRAPPING &
UNWRAPPING TOOLS



PAGE 15

COPPER WIRE CUT &
STRIP TOOLS

ENHANCING NETWORK RELIABILITY WITH OK INDUSTRIES



Founded in 1946, OK Industries is a major force in the telecommunications and electronics industries and is a division of a large diversified multinational corporation. We are a global supplier of hand tools for the interconnection of communications networks. Our dependable products employ precision technologies for the preparation and connection of copper and Fibre optic cables in applications including public and enterprise voice and data communications. Ask for OK Industries when you wish to build reliability into your networks.



FIBRE OPTIC CABLE STRIPPING TOOLS

For installers and technicians working with fibre optic cable, OK Industries offers the patented Micro-Strip® Series stripping tools. This innovative range of tools allows for quick, easy stripping of jackets, coatings and buffer materials, yet is designed to preserve the integrity of the glass core. Opposing stripping blades self-align around the fibre to assure concentric scoring and precision-stripped, nick-free fibre. The tools also include a fibre support channel, which maintains perpendicularity between the fibre and the blades; this helps to prevent core damage from flexing and bending. A thermal version is available to facilitate stripping of jackets, ribbon cables and other difficult applications.

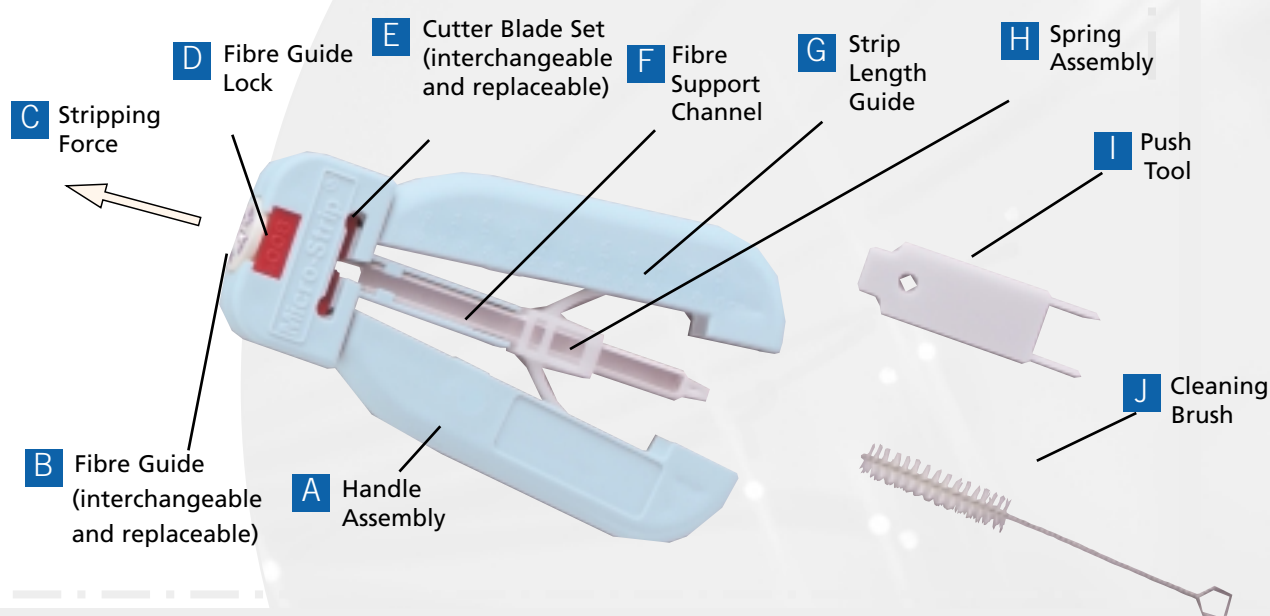

NON-THERMAL AND THERMAL STRIPPING TOOL FEATURES

A HANDLE ASSEMBLY
Standard stripping handle accepts interchangeable parts quickly and easily.

B FIBRE GUIDE
Selected for each normal diameter of unstripped buffer or cable. Wrong-sized fibre will not fit, assuring that fibre is precisely positioned, properly stripped, and not nicked or damaged.

C STRIPPING FORCE
is applied longitudinally with the fibre. The chance for harmful drag of

stripped fibre against the blade is virtually eliminated, even with operator inattention or fatigue.

D FIBRE GUIDE LOCK
holds the fibre guide securely in position. Colour-coded to match the cutter blade set.

E CUTTER BLADE SET
Can be selected for each FIBRE coating or cladding diameter. Opposing blades self-align around fibre guide to assure concentric scoring and precision-

stripped, nick-free fibre. Blades travel in a straight line to assure proper alignment. Colour coded to match the fibre lock.

F FIBRE SUPPORT CHANNEL
Guides fibre being stripped (up to 900µm) in straight line to prevent core damage from flexing or bending. For jacket stripping, cable support channel performs a similar function.

G STRIP LENGTH GUIDE
calibrated in 1/16" for desired strip lengths.

H SPRING ASSEMBLY
keeps handles apart, ready for next fibre or cable

I PUSH TOOL
(supplied with handle) makes installation and removal of cutter blade sets and fibre locks quick and easy.

J CLEANING BRUSH
(supplied with handle) effectively clears small pieces of residue from the tool.

Use these two standard handles to strip buffered fibre up to 900µm, or jacketed fibre up to 3.1mm, quickly and easily. Simply select and install the proper cutter blade sets, fibre guides and fibre guide locks. Or if you prefer, purchase Micro-Strip® and Soft-Strip® tools individually fitted for the fibre or jacket diameter you specify. Cutter blade sets, fibre guides and fibre guide locks come already installed.

COATING/BUFFER STRIPPING TOOL

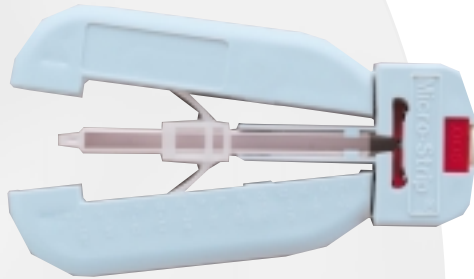

Cutter Blade set



Fibre Guide



Fibre-Guide Lock

THERMAL STRIPPING TOOL

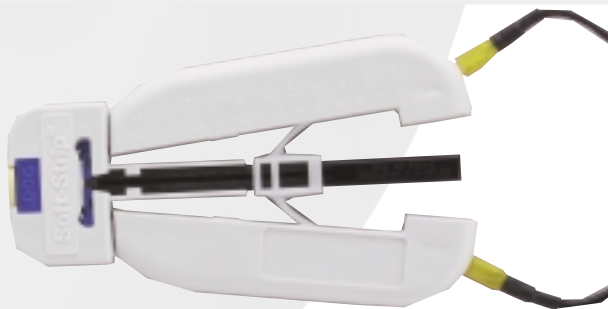

Cutter Blade set



Fibre Guide



Fibre-Guide Lock

◇ For best results use .0063 inch blade when removing a 250µm coating
 ◇◇ For best results use .0080 inch blade when removing a 900µm buffer.
 *Catalogue numbers are for two cutter blade sets packaged together with a matching Colour-coded fibre lock. Each cutter blade set consists of a pair of joined, matched blades which must be snapped apart prior to use. Matched cutter blade sets are NOT interchangeable, and must be used with their matching half. Catalogue numbers are for a single, individually packaged fibre guide with integral size indicator disk.
 †Includes tool individually boxed with cleaning brush, push tool and instructions.
 ††Catalogue numbers are for single individually packaged fibre Guide (with integral size indicator disk).

MICRO-STRIP ORDERING INFORMATION

NON-THERMAL TOOLS

COMPLETE TOOLS AND REPLACEMENT BLADE SETS

Material to be Stripped	Fibre Cladding Diameter to Expose or Jacket Dia. (µm)	Fibre Cladding Diameter to Expose or Jacket Dia. (in.)	Proper Blade Diameter (in.)	Complete Tool Catalogue Number †	Replacement Cutter Blade Set Catalogue Number *	Blade Colour Code
250µm Coating◇	125-135	.0049-.0053	.0063	FS-06S-13	FS-B-06S	Purple
900µm Buffer◇◇	125-175	.0049-.0068	.008	FS-08S-40	FS-B-08S	Red
2.5mm Jacket/900µm Buffer	125-140	.0049-.0068	.008	FS-08S-B5	FS-B-08S	Red
2.5mm Jacket	2.5	.098	.054	FS-54S-D1	FS-B-J54	Natural
3mm Jacket	3.0	.118	.054	FS-54S-D2	FS-B-J54	Natural

THERMAL TOOLS-SINGLE FIBRE

COMPLETE TOOLS AND REPLACEMENT BLADE SETS

Material to be Stripped	Fibre Cladding Diameter to Expose or Jacket Dia. (µm)	Fibre Cladding Diameter to Expose or Jacket Dia. (in.)	Proper Blade Diameter (in.)	Complete Tool Catalogue Number †	Replacement Cutter Blade Set Catalogue Number *	Blade Colour Code
AA BATTERIES						
250µm Coating◇	125-135	.0049-.0053	.0063	FST-4B-06S-13	FS-B-06S	Purple
900µm Buffer◇◇	125-175	.0049-.0068	.008	FST-4B-08S-40	FS-B-08S	Red
AC ADAPTER						
250µm Coating◇	125-135	.0049-.0053	.0063	FST-4T-06S-13	FS-B-06S	Purple
900µm Buffer◇◇	125-175	.0049-.0068	.008	FST-4T-08S-40	FS-B-08S	Red

THERMAL TOOLS-RIBBON FIBRE *

COMPLETE TOOLS AND REPLACEMENT BLADE SETS

Catalogue Number	Description	Replacement Blade Set	Replacement Ribbon Guide
FSTR-3B-06-G1	12- Fibre AT&T ASR Thermal Ribbon Stripper	FS-RB-06	FS-G-RG1
FSTR-3B-06-G2	12- Fibre Bonded/Ribbonised Stripper	FS-RB-06	FS-G-RG2
FSTR-3E-06-G3	4 Fibre Encapsulated Thermal Stripper	FS-RB-06	FS-G-RG3
FSTR-3E-06-G4	8 Fibre Encapsulated Thermal Stripper	FS-RB-06	FS-G-RG4
FSTR-3B-06-G5	4 Fibre Bonded Thermal Stripper	FS-RB-06	FS-G-RG5
FSTR-3B-06-G6	8 Fibre Bonded Thermal Stripper	FS-RB-06	FS-G-RG6
FSTR-3B-06-G8	10 Fibre Bonded Thermal Stripper	FS-RB-06	FS-G-RG8
FSTR-3B-06-G10	6 Fibre Bonded Thermal Stripper	FS-RB-06	FS-G-RG10
FSTR-3E-06-G15	12 Fibre Encapsulated Thermal Stripper	FS-RB-06	FS-G-RG15

* The Ribbon Fibre tools are all Electric Powered

NON-THERMAL KITS

FSK-1	Kit for 125/140 Cladding; 250/900 Coating; 2.5 & 3.0 mm Jackets
FSK-2	Kit for 125/250 Stripper; 125/900 Stripper; 2.5 or 3.0 mm Jacket Stripper; Kevlar Scissor
FSK-2A	Kit for 125/900 Buffer, 2.5MM jacket, scissors

FIBRE GUIDES

COATING OR BUFFER

JACKET

Fibre Coating or Buffer Dia. to Strip (µm)	Replacement Fibre Guide Cat. No ††	Jacket Diameter (µm)	Catalogue Number ††
≤250	FS-G-10	2.5	FS-G-26MM
250-343	FS-G-13	3.0	FS-G-31MM
407-457	FS-G-18		
457-533	FS-G-21		
533-635	FS-G-25		
635-787	FS-G-31		
787-889	FS-G-35		
889-1016	FS-G-40		

OTHER ACCESSORIES

FSH	Coating/Buffer Stripper Handle
FSKS	Kevlar Scissors
FS-CB-1	Blade Cleaning Brush
FS-PT-1	Blade & Guide Assembly Tool
FSCR-60-SW	FIBRE Optic Sapphire Wedge Scribe
FST-A-T3	U.S. AC Adapter (Thermal Stripper only)
FST-A-T4	U.K. AC Adapter (Thermal Stripper only)
FST-A-T5	Euro AC Adapter (Thermal Stripper only)
FST-A-T6	Australian AC Adapter (Thermal Stripper only)
FST-RHM-1	Heater Cartridge (FST-4B only)
FST-RHM-2	Heater Cartridge (FST-4T only)

NON-THERMAL STRIPPING

JACKET AND COATING

PROPER TOOL SELECTION

Select the proper tool and components for either fibre stripping or jacket stripping by referring to the tables on the back page. If necessary, install proper fibre guide, fibre guide lock and cutter blade set.

STRIPPING PROCEDURE (BUFFERED OPTICAL FIBRE TOOL)

Hold tool in one hand, fibre in the other. Keep handles in fully expandable position. Insert fibre through fibre guide until end aligns with rule markings to match desired strip length (1).

Squeeze handles closed. Cutter blades are now scoring the buffer or coating (2).

While maintaining a slight pressure to keep cutter closed, withdraw fibre from tool, completing the stripping process (3).

STRIPPING PROCEDURE (JACKETED FIBRE TOOL WITH LATCH BAR)

Insert cable through fibre guide. Align end of cable with rule marking at desired strip length (1).

Close handles together so blades cut into jacket (2).

While holding handles closed, flip latch bar down around pin. Release handles to latched, semi-open position. Do not reclose handles. Move hand up to grasp head of tool. While other hand is holding cable firmly, pull with a quick, smooth motion. Flip latch off pin. Stripped jacket will fall out through rear of channel when handles are fully opened. Note: Never leave tool with latch bar in locked position. This can cause Delrin spring to take a set, preventing handles from opening fully. When stripping hard, tough or thick jackets, it is not necessary to use latch bar. Lock bar out of the way by tightening the screw.



1 Insert correct fibre through guide and into support channel to desired strip length.



2 Close handles. Blade sets cut almost through the buffer or jacket without ever touching the fibre.



3 With handles closed, pull fibre or cable from tool. Always a precision strip length. fibre is never nicked or damaged.

PATENTED, SELF-CENTERING MICRO-STRIP® STRIPPING SYSTEM ASSURES PRECISE, CONCENTRIC SCORING, WITHOUT CLADDING OR CORE DAMAGE.

SNAP-APART PRECISION-MACHINED BLADE HALVES MOLDED INTO THERMOPLASTIC BODIES.

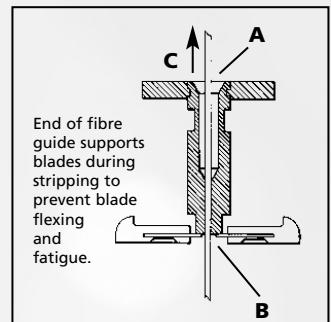
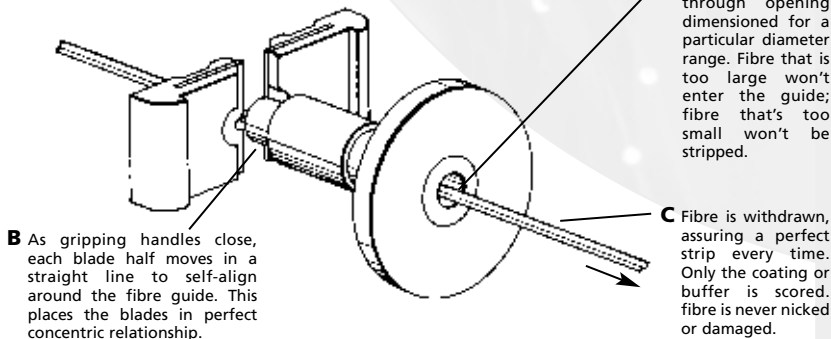

CAUTION
Always wear approved eye protection when working with any type of fibre optic cable or wire.

THERMAL STRIPPING

GENERAL

Strip outer jacket (if any), using Soft-Strip® non-thermal tool. Install and connect battery(s), or install and connect AC adapter. Install proper cutter blade set, fibre guide and fibre guide lock.

HEATER OVEN

Unit is activated when handles are closed. Close handles only when stripping. Check heater operation by closing handles firmly for no longer than 10 seconds. Nose end of heater should be warm to the touch.

After stripping operation, remove heater oven from tool and clean with the brush provided (spring assembly in later models includes automatic scrap ejector.) Reinsert, making sure that heater oven is pushed completely forward toward the blade area and snaps into place. 2" heater oven area should be visible at front of tool so operator can monitor positioning and preheating of coating.

CUTTER BLADE REPLACEMENT INSTRUCTION PROCEDURE FOR NON-THERMAL AND THERMAL SOFT-STRIP® STRIPPING TOOLS

TO REMOVE INSTALLED BLADES:

1. Using flat end of push tool, remove fibre guide lock by pushing out from back side of tool head.
2. Remove fibre guide from tool.
3. Using prong end of push tool in small holes on back side of tool head, eject blade set.

IMPORTANT Do not remove cutter blades while fibre guide is still in tool.

TO INSTALL NEW BLADES:

(Furnished in a matched set for blade position.

Snap apart before installation.)

1. Install with "ears" pointing toward top of tool and recess marks visible. Push firmly with flat end of push tool until both blades are seated.
2. Insert fibre guide through hole in top of tool until it stops.
3. Insert fibre guide lock through slot in front of tool head.

NOTE: Blades are Colour coded and matched to diameter and Colour of fibre guide lock. Replace or install fibre guide and guide lock as needed. Always test-strip fibre or cable after installing new blade set. Remove blades periodically and clean with brush provided and alcohol.

CAUTION: Heater units continuously when handles are closed. Do not hold handles closed for longer than 20 seconds for AA and D-Size battery units, 10 seconds for 6-Volt battery/AC adapter units, or overheating can damage tool. Do not touch heater oven while in operation. Allow oven to cool before removal and cleaning.



- 1 Insert fibre through fibre guide and into heater oven to desired length. Be sure buffered fibre is flat in the oven channel. Always allow at least 1/8" gap from fibre tip to end of oven channel. Otherwise heater oven movement will cause fibre to buckle up and out of heating zone.



- 2 Close handles all the way. Blades are precisely aligned for concentric scoring without cladding, core or conductor damage. Heater oven is automatically activated to start the softening process.

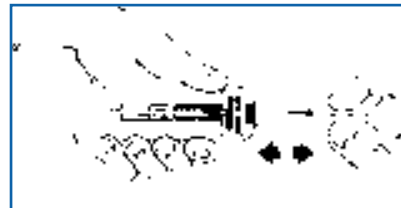

- 3 Keep handles closed (AA or D-size 10-20 sec., 6V or AC adapter 4-8 sec.) for optimum softening. Then begin to pull the fibre, slowly increasing pull force until coating releases from the fibre. Remove the fibre from the tool with a smooth, even motion.

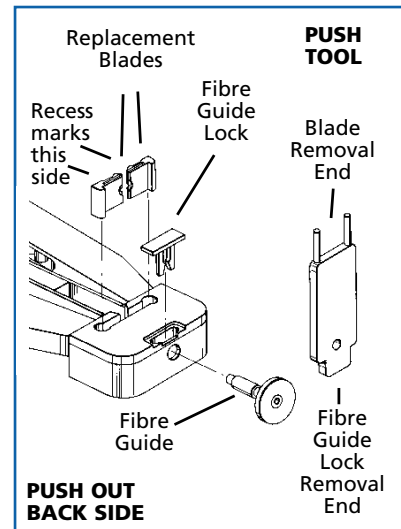

WIRE WRAPPING OVERVIEW

Wire Wrapping is a method of making a wire connection by coiling the bare wire around the sharp corners of a terminal under mechanical tension. The technology was developed as an alternative to soldering, which presents various safety and reliability problems in many applications. A principal advantage of wire wrapping is that it provides a high-reliability connection that is also easily removed to correct or modify a wiring layout. Wire wrapping subjects the wire to tremendous tension and compression forces, causing the oxide layer on both wire and terminal to be crushed or sheared, resulting in a clean, oxide-free metal-to-metal contact. A standard wrap is generally used for 24 AWG and larger diameter wires; a modified wrap is typically used for 24 AWG and smaller wires, and is used almost exclusively for 28 to 30 AWG wires. In either case, the wrap style affects only the connection's mechanical stability; both styles provide suitable electrical connections.

METAL-TO-METAL CONTACT

By bending the wire around the sharp corner of the terminal, the oxide layer on both wire and terminal is crushed or sheared, and a clean, oxide-free metal-to-metal contact is obtained.

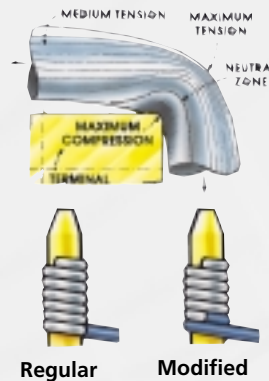

STRIP FORCE CHART

AWG	Wire Size		Min. number of turns (Bare Wire)	Min. strip force	
	Dia. inches	Dia. mm		lbs.	gms
16	.051	1.30	4	15	6800
18	.0403	1.00	4	15	6800
20	.032	0.80	5	8	3600
22	.0253	0.65	5	8	3600
24	.0201	0.50	6	7	3200
26	.0159	0.40	7	6	2700
28	.0126	0.32	7	5	2200
30	.0100	0.25	7	3.3	1500

*Conforms to MIL-STD-1130B

TYPES OF WRAP

A "Regular" bit wraps the bare wire around the terminal. A "Modified" bit wraps a portion of insulation around the terminal in addition to the bare wire. This greatly increases the ability to withstand vibration.

HOW TO MAKE WIRE WRAPPED CONNECTIONS



SOME HINTS ON MAKING WRAPPED CONNECTIONS

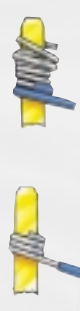

OVERWRAP
Do not press too hard. Let the OK tools do the work. Excessive pressure can lead to overwrapping. Backforce "BF" to prevent overwrapping is available on most power tools and is recommended for use with 26 through 30 AWG wire.

INSUFFICIENT TURNS
It's easy to feed wire into the slot in the OK bit correctly. Be sure the stripped end of the wire is "pushed-in" all the way.



OPEN WRAP & SPIRAL WRAP
Just keep the OK tool on the terminal until the wrap is complete. Early removal can result in spiral and open wraps.

PIGTAIL
Wire wrapping is a precision technique and the wrong bit and sleeve just cannot do the job. Improper selection can cause problems ranging from "Pigtails" to loose wraps.

TERMINAL DIAGONAL CHART

In. mm	.010 0.25	.015 0.38	.020 0.51	.025 0.64	.030 0.76	.035 0.89	.040 1.02	.045 1.14	.050 1.27	.055 1.40	.060 1.52	.065 1.65	.070 1.78	.075 1.91	.080 2.03	.085 2.16	.090 2.29	.095 2.41	.100 2.54
.010 0.25	.014 0.36	.018 0.46	.022 0.56	.027 0.69	.032 0.81	.036 0.91	.041 1.04	.046 1.17	.051 1.30	.056 1.42	.061 1.55	.066 1.68	.071 1.80	.076 1.93	.081 2.06	.086 2.18	.091 2.31	.096 2.44	.101 2.57
.015 0.38	.018 0.46	.021 0.53	.025 0.64	.029 0.74	.033 0.84	.038 0.97	.043 1.09	.047 1.19	.052 1.32	.057 1.45	.062 1.58	.067 1.70	.072 1.83	.077 1.96	.082 2.08	.087 2.21	.092 2.34	.097 2.46	.102 2.59
.020 0.51	.022 0.56	.025 0.64	.028 0.71	.032 0.81	.036 0.91	.040 1.02	.045 1.14	.049 1.25	.053 1.35	.058 1.47	.063 1.60	.068 1.73	.073 1.85	.078 1.98	.083 2.11	.088 2.24	.093 2.36	.098 2.49	.103 2.62
.025 0.64	.027 0.69	.029 0.74	.032 0.81	.035 0.89	.039 0.99	.043 1.09	.047 1.19	.050 1.27	.056 1.42	.060 1.52	.065 1.65	.069 1.75	.074 1.88	.079 2.01	.084 2.13	.089 2.26	.094 2.39	.099 2.52	.104 2.64
.030 0.76	.032 0.81	.033 0.84	.036 0.91	.039 0.99	.042 1.07	.046 1.17	.050 1.27	.054 1.37	.058 1.47	.062 1.58	.067 1.70	.071 1.80	.076 1.93	.080 2.03	.085 2.16	.090 2.29	.095 2.41	.100 2.54	.105 2.67
.035 0.89	.036 0.91	.038 0.97	.040 1.02	.043 1.09	.046 1.17	.049 1.25	.052 1.32	.056 1.42	.060 1.52	.064 1.63	.069 1.75	.073 1.85	.078 1.98	.082 2.08	.087 2.21	.091 2.31	.096 2.44	.101 2.57	.106 2.69
.040 1.02	.041 1.04	.043 1.09	.045 1.14	.047 1.19	.050 1.27	.052 1.32	.056 1.42	.060 1.52	.064 1.63	.068 1.73	.072 1.83	.076 1.93	.080 2.03	.084 2.13	.089 2.26	.092 2.34	.097 2.46	.102 2.59	.107 2.72
.045 1.14	.046 1.17	.047 1.19	.049 1.25	.050 1.27	.054 1.37	.056 1.42	.060 1.52	.063 1.60	.067 1.70	.071 1.80	.074 1.88	.078 1.98	.083 2.11	.087 2.21	.091 2.31	.096 2.44	.101 2.57	.105 2.67	.109 2.77
.050 1.27	.051 1.30	.052 1.32	.053 1.35	.056 1.42	.058 1.47	.060 1.52	.064 1.63	.067 1.70	.071 1.80	.074 1.88	.078 1.98	.082 2.08	.086 2.18	.090 2.29	.094 2.39	.098 2.49	.103 2.62	.107 2.72	.111 2.82

Example: If "E"=.020". "F"=.060". The terminal diagonal is .063" as shown on chart.

PTX SERIES

ERGONOMIC WIRE WRAPPING TOOLS



The PTX Series Wire Wrapping Tools from OK Industries bring revolutionary new benefits to installers, telecom technicians and other users. With worker safety in mind, we consulted a certified ergonomist and created an ergonomic tool, which includes a lightweight, well-balanced construction, dual-finger short-throw trigger, and a long handle to mitigate pressure on the palm. These features help to prevent repetitive stresses and result in an industry-leading design from a comfort and safety standpoint. Ask for the PTX Series Wire Wrapping Tools from OK Industries — and arm your workers with the tools that offer efficiency and worker safety in your interconnect activity.

KEY FEATURES

- Ergonomic Design — Minimises Repetitive Stress
- Rugged Construction for Field Usage
- Battery and Electric Powered Versions Available
- Wraps and Unwraps 20 to 30 AWG Wire
- Rated Maximum Usage: 2,500 cycles/day
- For Bits & Sleeves: see Page 11

Part No.	Description	Weight	Voltage	RPM
PTX	Battery Wrap/Unwrap Tool (Battery not included)	1.2 lb.	3.6V*	3700
PTX-1	Electric Wrap/Unwrap Tool - 115V	0.86 lb.	115V	3700
PTX-1BF	Electric Wrap/Unwrap Tool w/Backforce - 115V	0.86 lb.	115V	3700
PTX-2	Electric Wrap/Unwrap Tool - 230V	1.0 lb.	230V	4200
PTX-2-UK	Electric Wrap/Unwrap Tool - UK Plug - 230V	1.0 lb.	230V	4200
PTX-2BF	Electric Wrap/Unwrap Tool w/Backforce - 230V	1.0 lb.	230V	4200
PTX-2BF-UK	Electric Wrap/Unwrap Tool w/Backforce - UK Plug - 230V	1.0 lb.	230V	4200
PTX-KIT1	115V battery tool kit (tool, charger, (2) batteries)			
PTX-KIT2	230V battery tool kit (tool, charger, (2) batteries)			
PTX-KIT2-UK	230V battery tool kit w/ UK Plug (tool, charger, (2) batteries)			

* Powered by long-life NiMH battery

ACCESSORIES

- **PTX-B** PTX Battery, 3.6V
- **PTX-BC1** 115V Charger for PTX-B battery
- **PTX-BC2** 230V Charger for PTX-B battery
- **PTX-BC2-UK** 230V Charger with UK Plug for PTX-B battery

PTX-BC1



PTX-B

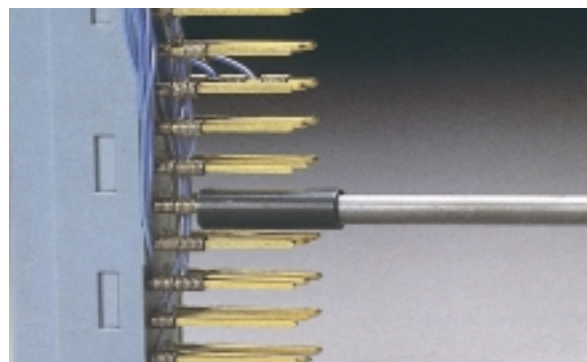

MANUAL WIRE WRAPPING TOOLS & KITS

MANUAL WIRE WRAPPING TOOLS



G100/R3278INS
(Shown with Bit/Sleeve)

G200/R3278 Lexan™
G100/R3278 Aluminum

The G100/R3278 and G200/R3278 tools are designed with a chuck nose piece to make use of the full line of bits and sleeves made for power tools. The G100/R3278INS is coated with an insulative material, providing 1000V of dielectric strength across most of the housing, to help ensure worker and system safety. These tools accommodate wire sizes from 22 AWG (0.65mm) thru 32 AWG (0.20mm).

- G200/R3278 : Lexan™
- G200/R3278-K : Speed Wrap Tool kit
- G100/R3278 : Aluminum
- G100/R3278INS : Aluminum (insulated)
- For Bits & Sleeves : see page 11

MANUAL WIRE UNWRAPPING TOOL

The combination of the G100/R3394 unwrap tool and the SU unwrap bits gives you the best tool for high speed wire unwrapping. High production, long life, low maintenance. Use Unwrap Set SU2026 for wire AWG 20 thru 26 (0.80 thru 0.40mm) and Set SU2832 for wire AWG 26 thru 32 (0.40 thru 0.20mm).



G100/R3394

- G100/R3394 : Manual Wire Unwrapping Tool

G100/R3394 Bits & Sleeves:

Unwrap Bit Part No.	Unwrap Sleeve Part No.	Bit and Sleeve Set No.	Wire Size		Terminal Hole Diameter	
			AWG	mm	Inches	mm
2026UB	2032	SU2026	22-26	0.65-0.40	.070	1.77
2832UB	2032	SU2832	26-32	0.40-0.20	.036	0.96

TELECOM WIRE WRAP KIT



WWK-1

This is a complete kit for technicians working at a Main Distributing Frame. The G200/R3278 Manual Gun produces wire wrapped connections merely by squeezing the trigger, and works with any bit and sleeve. The versatile HW-UW-224 Hand Wrap-Unwrap Tool (22-24 AWG) does the work of two tools in one - wrapping and unwrapping - just by changing the cap from one end to the other. The ST-100 22-24 AWG wire Cut-and-Strip Tool offers easy, clean stripping of up to four wires with 15/16" - 19/16" adjustable strip off length. This kit comes complete with KB224 22-24 AWG bit, P2224 22-24 AWG sleeve and H-1000 cordura tool pouch.

- WWK-1 : Telecom Wire Wrap Kit

WIRE WRAPPING BITS & SLEEVES

Fully compatible with any make or model wire wrapping tool, except G100 and G200 manual tools, which are obsolete and require special bits and sleeves.

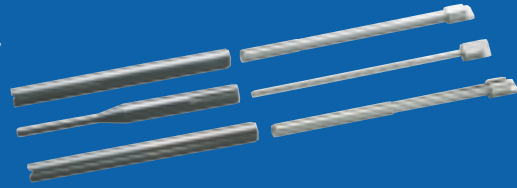

BITS AND SLEEVES CHART (AWG) INCHES

Wire Gauge (AWG)	Regular	Modified	Bit Part No.	Sleeve Part No.	Maximum Insulation Diameter Inches	Minimum Terminal Diagonal Inches	Maximum Terminal Diagonal Inches	Terminal Hole Depth Inches	Effective Radius Inches	Terminal Hole Diameter Inches
18	●		KB18	P194	-	.060	.073	1.00	.150	.075
20		●	WB20M	P194LN	.059	.042	.073	1.000	.150	.075
20-22	●		KB2075	P2224	-	.042	.073	1.000	.123	.075
22	●		KB22LT	P2224	-	.061	.085	1.000	.125	.086
22	●		KB22	P2224	-	.054	.073	.750	.117	.075
22		●	WB2275M	P2224	.052	.049	.074	1.000	.132	.075
22-24	●		KB224LH	P2224	-	.061	.085	1.000	.117	.086
22-24	●		KB224-1	P2224	-	.054	.073	1.000	.111	.075
22-24	●		KB224	P2224	-	.054	.073	.807	.111	.075
22-24		●	WB224M	P2224	.050	.049	.074	1.250	.121	.075
24	●		*KB2444	P3032LN	-	.024	.043	1.000	.083	.044
24		●	WB24DH	P2224	.046	.054	.073	1.750	.117	.075
24	●		KB24	P2426	-	.055	.074	.750	.100	.075
24		●	*WB245M	P3032LN	.044	.024	.043	.750	.098	.044
24		●	WB24DHM	P2224	.050	.049	.068	1.125	.118	.069
24-26		●	WB2426M	P2224	.046	.054	.073	.750	.118	.075
24-26	●		KB2466	OK8519	-	.054	.065	1.000	.098	.066
26	●		*KB2639	P26LN	-	.023	.038	.750	.068	.040
26	●		KB26	P2426	-	.058	.073	1.000	.100	.075
26		●	*WB265M	P26LN	.031	.023	.038	.750	.075	.040
26		●	WB26M	P2224	.046	.054	.073	1.000	.118	.075
26		●	*WB2644M	P3032LN	.046	.024	.043	.750	.098	.044
26		●	WB2669M	P2426	.041	.053	.068	1.000	.109	.069
28		●	WB2870M	P2426	.034	.053	.068	1.000	.103	.070
28-29		●	*WB2829M	P3032L	.036	.033	.038	.750	.091	.040
30		●	*SB30MSH-B	P3032	.027	.031	.035	.750	.064	.036
30		●	*SB30MMK	P3032	.023	.031	.035	.750	.064	.036
30-32		●	*WB3032M	P3032	.027	.034	.038	.750	.064	.040

*These tools are recommended for .025" square terminals on .100 centres

BITS AND SLEEVES CHART MILLIMETRES

Wire Gauge mm	Regular	Modified	Bit Part No.	Sleeve Part No.	Maximum Insulation Diameter mm	Minimum Terminal Diagonal mm	Maximum Terminal Diagonal mm	Terminal Hole Depth mm	Effective Radius mm	Terminal Hole Diameter mm
1.00	●		KB18	P194	-	1.52	1.85	25.40	3.81	1.90
0.80		●	WB20M	P194LN	1.50	1.07	1.85	25.40	3.81	1.90
0.65-0.80	●		KB2075	P2224	-	1.07	1.85	25.40	3.12	1.90
0.65	●		KB22LT	P2224	-	1.54	2.15	25.40	3.17	2.18
0.65	●		KB22	P2224	-	1.37	1.85	19.05	2.97	1.90
0.65		●	WB2275M	P2224	1.32	1.24	1.87	25.40	3.35	1.90
0.50-0.65	●		KB224LH	P2224	-	1.54	2.15	25.40	2.97	2.18
0.50-0.65	●		KB224-1	P2224	-	1.37	1.85	25.40	2.82	1.90
0.50-0.65	●		KB224	P2224	-	1.37	1.85	20.50	2.82	1.90
0.50-0.65		●	WB224M	P2224	1.27	1.24	1.87	31.75	3.07	1.90
0.50	●		*KB2444	P3032LN	-	0.60	1.09	25.40	2.10	1.11
0.50		●	WB24DH	P2224	1.17	1.37	1.85	44.50	2.97	1.90
0.50	●		KB24	P2426	-	1.39	1.87	19.05	2.54	1.90
0.50		●	*WB245M	P3032LN	1.11	0.60	1.09	19.05	2.48	1.11
0.50		●	WB24DHM	P2224	1.27	1.24	1.72	28.50	2.99	1.75
0.40-0.50		●	WB2426M	P2224	1.17	1.37	1.85	19.05	2.99	1.90
0.40-0.50	●		KB2466	OK8519	-	1.37	1.65	25.40	2.48	1.67
0.40	●		*KB2639	P26LN	-	0.58	0.96	19.05	1.72	1.02
0.40	●		KB26	P2426	-	1.47	1.85	25.40	2.54	1.90
0.40		●	*WB265M	P26LN	0.79	0.58	0.96	19.05	1.70	1.02
0.40		●	WB26M	P2224	1.17	1.37	1.85	25.40	2.99	1.90
0.40		●	*WB2644M	P3032LN	1.17	0.60	1.09	19.05	2.48	1.11
0.40		●	WB2669M	P2426	1.04	1.34	1.72	25.40	2.77	1.75
0.32		●	*WB28SHM	P3032	0.76	0.79	0.89	19.05	1.67	0.91
0.29-0.32		●	*WB2829M	P3032L	0.91	0.83	0.96	19.05	2.31	1.02
0.25		●	*SB30MSH-B	P3032	0.69	0.79	0.89	19.05	1.62	0.91
0.25		●	*SB30MMK	P3032	0.58	0.79	0.89	19.05	1.62	0.91
0.20-0.25		●	*WB3032M	P3032	0.69	0.86	0.96	19.05	1.62	1.02

* These tools are recommended for 0.63mm terminals on 2.54mm centres

SPECIALISED BITS & SLEEVES

POWER UNWRAPPING BITS & SLEEVES

For PTX Series battery or electric wrap/unwrap tool.

Unwrap Bit Part No.	Unwrap Sleeve Part No.	Bit and Sleeve Set	Wire Size		Terminal Hole Dia.	
			AWG	mm	In.	mm
2026UB	SOK-2230	PUW-2226	20-26	0.80-0.40	.070	1.77
2832UB	SOK-2230	PUW2830	26-32	0.40-0.20	.038	0.96

2" (5CM) LONGER THAN STANDARD BITS & SLEEVES



These bits and sleeves are designed for wire wrapping in areas requiring deep penetration. Their 5" (127mm) length ensures "true" connections in hard-to-get-at locations.

Bit Part No.	Sleeve Part No.	Wire Size		Regular	Modified	Maximum Insulation Diameter		Minimum Terminal Diagonal		Maximum Terminal Diagonal		Terminal Hole Depth		Effective Radius		Terminal Hole Diameter	
		AWG	mm			In.	mm	In.	mm	In.	mm	In.	mm	In.	mm	In.	mm
KB22-5	P2224-5	22	0.65	●		-	-	.054	1.37	.073	1.85	.750	19.05	.117	2.97	.075	1.90
KB24-5	P2426-5	24	0.50	●		-	-	.055	1.39	.073	1.85	.750	19.05	.100	2.54	.075	1.90
KB26-5	P2426-5	26	0.40	●		-	-	.058	1.47	.073	1.85	.750	19.05	.100	2.54	.075	1.90

WIRE WRAPPING EXTENSION ATTACHMENTS

- EXT-400 : 4.0" (100mm) extension



Precision devices which attach easily to your wire wrapping tool for applications requiring extra "reach". Simply install the extension into the tool, then install the bit and sleeve into the extension. Fits all Electric and Manual wire wrapping tools. Compatible with all bits and sleeves made for Power Wire Wrapping Tools.

BITS AND INSULATED SLEEVES

The insulated sleeves are covered with a material which provides 1000V dielectric strength which helps to prevent shorting between pins and enhances worker safety.

P2426-5INS



KB24-5

Bit Part No.	Sleeve Part No.	Wire Size		Regular	Modified	Maximum Insulation Diameter		Minimum Terminal Diagonal		Maximum Terminal Diagonal		Terminal Hole Depth		Effective Radius		Terminal Hole Diameter	
		AWG	mm			In.	mm	In.	mm	In.	mm	In.	mm	In.	mm		
KB22	P2224INS	22	0.65	●		-	-	.054	1.37	.073	1.85	.750	19.05	.117	2.97	.075	1.90
KB224	P2224INS	22-24	0.50-0.65	●		-	-	.054	1.37	.073	1.85	.807	20.50	.111	2.82	.075	1.90
KB24	P2426INS	26	0.50	●		-	-	.055	1.39	.074	1.87	.750	19.05	.100	2.54	.075	1.90
KB26	P2426INS	26	0.40	●		-	-	.058	1.47	.073	1.85	1.0	25.40	.100	2.54	.075	1.90

EXTENDED LENGTH (5") BITS AND INSULATED SLEEVES

Bit Part No.	Sleeve Part No.	Wire Size		Regular	Modified	Maximum Insulation Diameter		Minimum Terminal Diagonal		Maximum Terminal Diagonal		Terminal Hole Depth		Effective Radius		Terminal Hole Diameter	
		AWG	mm			In.	mm	In.	mm	In.	mm	In.	mm	In.	mm		
KB22-5	P2224-5INS	22	0.65	●		-	-	.054	1.37	.073	1.85	.750	19.05	.117	2.97	.075	1.90
KB24-5	P2426-5INS	24	0.50	●		-	-	.055	1.39	.073	1.85	.750	19.05	.100	2.54	.075	1.90
KB26-5	P2426-5INS	26	0.40	●		-	-	.058	1.47	.073	1.85	.750	19.05	.100	2.54	.075	1.90

DFB224 DUAL FUNCTION WRAP/UNWRAP BIT & SLEEVE SET



OK INDUSTRIES INTRODUCES THE DFB224 DUAL FUNCTION BIT

This innovative product represents a truly revolutionary approach to wire wrapping, by combining both the wrap and the unwrap functions into one bit/sleeve set. The bit is precision machined for high quality wrapping in the clockwise direction, but also includes the removal mechanism that is used to unwrap when operated counterclockwise. The user can quickly and easily switch back and forth between wrap and unwrap mode by retracting or extending the retractable sleeve, and flipping the switch on a wrap/unwrap power tool (i.e., a power wire wrapping tool with reversible motor). This product, which can wrap or unwrap 22 and 24 AWG wire, enables the user to maximize operating efficiency while eliminating the need to purchase and carry extra tools or bits for unwrapping. Also, to prevent pin-to-pin shorting, the retractable sleeve is coated with a durable 1000V dielectric material.

Part #	Description	Wire Size		Min. Terminal Diagonal		Max. Terminal Diagonal		Terminal Hole Depth		Terminal Hole Diameter		Effective Radius	
		mm	AWG	mm	in.	mm	in.	mm	in.	mm	in.	mm	in.
DFB224	Dual Function Wrap/Unwrap Bit/Sleeve Set, 22/24 AWG	.50/.65	22/24	1.37	.054	1.85	.073	25.04	1.00	1.90	.075	2.82	.111
DFB2426	Dual Wrap/Unwrap bit & sleeve set, 24-26 AWG	.40/.50	24/26	1.37	.054	1.85	.073	25.04	1.00	1.67	.066	2.48	.098

KB-DF224 (wrap/unwrap bit)
P-DF2224 (wrap/unwrap sleeve assembly)

KB-DF2426 (replacement bit for DFB2426)
P-DF2426 (replacement Sleeve Assy, DFB2426)

HOW TO USE THE DFB224

The Wrap/Unwrap bit is shipped with the sleeve set in the wrap position. To change to the unwrap simply pull the sleeve out approximately 1/4" (the sleeve is spring loaded and you should feel some tension while pulling forward), rotate the sleeve in either direction 180° and release. The sleeve should now be seated approximately 1/4" lower than in the wrap position. This will expose the unwrap feature on the bit.

To change back to the wrap position pull the sleeve out approximately 1/2" and rotate the sleeve in either direction 180° and release. The spout should be in the 12:00 position and the sleeve should be locked in position.

Note: If you cannot rotate the sleeve, you need to pull the sleeve out further before trying to rotate the sleeve.

HAND WRAPPING AND UNWRAPPING TOOLS

HAND WRAPPING TOOLS

These Hand Wrapping Tools are carefully designed to produce perfect wire wrapped connections. Precision, long-lasting tools for use where occasional wraps are required or where power wire-wrapping tools are not practical. Compact and convenient.

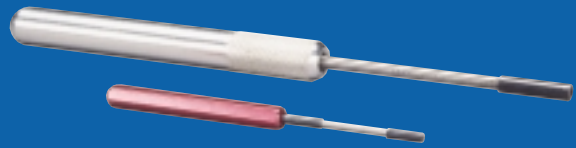

Part No.	Reg.	Mod.	Type	Wire Size		Max. Insulation Diameter		Terminal Hole Diameter		Terminal Hole Depth		Outside Diameter	
				AWG	mm	Inches	mm	Inches	mm	Inches	mm	Inches	mm
HW-224	●		A	22-24	0.65-0.50	-	-	.075	1.90	.807	20.50	.218	5.53
HW-224LH	●		A	22-24	0.65-0.50	-	-	.086	2.18	1.000	25.40	.218	5.53
HW-24DHM		●	A	24	0.50	.050	1.27	.069	1.75	1.125	28.50	.218	5.53
HW-2426	●		A	24-26	0.50-0.40	-	-	.075	1.90	.750	19.05	.218	5.53
HW-26	●		A	26	0.40	-	-	.075	1.90	1.000	25.40	.218	5.53
*HW-26SM		●	A	26	0.40	.031	0.79	.040	1.02	.750	19.05	.125	3.17
*HW-30		●	B	30	0.25	.027	0.69	.036	0.91	.750	19.05	.125	3.17

*These tools are recommended for .025" (0.63mm) square terminals on .100" (2.54mm) centres

Note: HW-22 and HW-24 have been replaced by HW-224.

HAND UNWRAPPING TOOLS

These tools are used to remove wire connections using 18 thru 32 gauge wire.

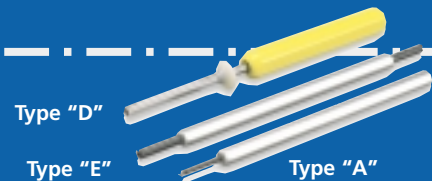

Part No.	Type	Wire Size		Type of Unwrap	Terminal Hole Diameter		Terminal Hole Depth		Outside Diameter	
		AWG	mm		Inches	mm	Inches	mm	Inches	mm
UW1	A	20-26	0.80-0.40	Left Hand	.070	1.77	1.000	25.40	.156	3.96
UW2	E	20-26	0.80-0.40	Left and Right Hand	.070	1.77	1.000	25.40	.156	3.96
UW4	D	20-26	0.80-0.40	Left Hand	.070	1.77	2.360	60.00	.187	4.74
UW5	D	20-26	0.80-0.40	Left and Right Hand	.070	1.77	2.360	60.00	.187	4.74
UWD93-93	E	24-32	0.50-0.20	Left and Right Hand	.038	0.96	1.000	25.40	.093	2.36
UW2832C	D	28-32	0.32-0.20	Left and Right Hand	.038	0.96	.750	19.05	.156	3.96

HAND WRAPPING AND UNWRAPPING TOOLS

To switch from wire wrapping to unwrapping takes only seconds - just a quick change of the cap from one end to the other.



WRAPPING SIDE

UNWRAPPING SIDE

Part Number	Reg	Mod	Wire Size		Max. Insulation Diameter		Terminal Hole Diameter		Terminal Hole Depth		Outside Diameter		Wire Size		Terminal Hole Diameter		Terminal Hole Depth		Outside Diameter	
			AWG	mm	In.	mm	In.	mm	In.	mm	In.	mm	In.	mm	AWG	mm	In.	mm	In.	mm
HW-UW-224	●		22-24	0.50 0.65	-	-	.075	1.90	.807	20.50	.218	5.53	20-26	0.80 0.40	.070	1.77	1.000	25.40	.156	3.96
HW-UW-224-1	●		22-24	0.50 0.65	-	-	.075	1.90	1.000	25.40	.218	5.53	20-26	0.80 0.40	.070	1.77	1.000	25.40	.156	3.96
HW-UW-224LH	●		22-24	0.50 0.65	-	-	.086	2.18	1.000	25.40	.218	5.53	20-26	0.80 0.40	.086	2.18	.750	19.05	.156	3.96
HW-UW-24DHM		●	24	0.50	.050	1.27	.069	1.75	1.125	28.50	.218	5.53	20-26	0.80 0.40	.070	1.77	1.000	25.40	.156	3.96
*HW-UW-24SM		●	24	0.50	.044	1.11	.044	1.11	.750	19.05	.156	3.96	20-26	0.80 0.40	.038	0.96	1.000	25.40	.093	2.36
HW-UW-2426	●		24-26	0.40 0.50	-	-	.075	1.90	.750	19.05	.218	5.53	20-26	0.80 0.40	.070	1.77	1.000	25.40	.156	3.96
HW-UW-26	●		26	0.40	-	-	.075	1.90	1.000	25.40	.218	5.53	20-26	0.80 0.40	.070	1.77	1.000	25.40	.156	3.96
*HW-UW-26SM		●	26	0.40	.031	0.79	.040	1.02	.750	19.05	.125	3.17	24-32	0.50 0.20	.038	0.96	1.000	25.40	.093	2.36

*These tools are recommended for .025" (0.63mm) square terminals on .100" (2.54mm) centres.

Note: HW-UW-22 and HW-UW-24 have been replaced by HW-UW-224.

COPPER WIRE CUT & STRIP TOOLS

WIRE CUT-AND-STRIP TOOLS - ST-100 SERIES

A revolutionary concept for easy and clean stripping of wires for wire wrapping, electronic and appliance applications. Biomechanically designed for maximum efficiency. Easy to operate... place wire (up to 4) in stripping slot with ends extending beyond cutter blades... press tool and pull... wire is cut and stripped to proper "wire wrapping" length. The hardened steel cutting blades and sturdy construction of the tool ensure long life. Strip length easily adjustable for your application.

Part No.	Wire Size		Adjustable Strip-Off Length	
	AWG	mm	Inches	mm
ST-100	22-24	0.65-0.50	1-5/16" to 1-9/16"	33.33 to 39.68
ST-100-24	24	0.50	1-5/16" to 1-5/16"	33.33 to 39.68
ST-100-24-875	24	0.50	7/8" to 1-2/8"	22.22 to 28.57
ST-100-26	26	0.40	1-5/16" to 1-11/16"	33.33 to 42.86
ST-100-26SP	26	0.40	1-1/2" to 2"	38.10 to 50.80
ST-100-26-875	26	0.40	7/8" to 1-1/8"	22.22 to 28.57
ST-100-28	28	0.32	7/8" to 1-1/8"	22.22 to 28.57
ST-100-30	30	0.25	7/8" to 1-1/8"	22.22 to 28.57



ST-100-30

- Replacement Blade/Blade Supports
 - Weight: 5.1 o.z (144.6 gms)
 - Length: 6.75" (171.5 mm)

BLADE AND BLADE SUPPORT REPLACEMENTS: ST-100 SERIES AND OK-3907 SERIES

Replacement blades are interchangeable between ST-100 series and OK-3907 wire-stripping tools. These fine blades are made from specially tempered spring steel. The stripping slot is carefully centered within the blade to ensure clean, no nick stripping. The replacement blade support sections are made of heat treated plated steel. They are designed to accurately centre the slots of the stripping blade, making possible clean, nick-free wire stripping. Easy replacement.

Replacement Blade	Replacement Blade Support	For use with:	
OK-3907-B	3907-BS-224	OK-3907	ST-100
OK-3907-24B	3907-BS-2030	OK-3907-24	ST-100-24
OK-3907-26B	3907-BS-2030	OK-3907-26	ST-100-26
OK-3907-26B	3907-BS-2030	OK-3907-26SP	ST-100-26SP & 875
OK-3907-28B	3907-BS-2030	OK-3907-28	ST-100-28
OK-3907-30B	3907-BS-2030	OK-3907-30	ST-100-30

ADJUSTABLE PRECISION WIRE STRIPPERS OK-3907 SERIES

The OK-3907 Series from OK Industries is the industry's leading cut-and-strip tool for cooper interconnect applications. Installers and telecom technicians enjoy its rugged construction, comfortable rubber grips, and high-leverage handle design, which allows time savings through the simultaneous cutting of multiple wires. The OK-3907-26 applies to 26-gauge wire. Replacement cutting blades and blade supports are also available.

Part No.	Wire Size		Adjustable Strip-Off Length	
	AWG	mm	Inches	mm
OK-3907	22-24	0.65	1-1/2" to 1-3/4"	38.10 to 44.45
OK-3907-26	26	0.40	1-1/2" to 1-3/4"	38.10 to 44.45



OK-3907



OK Industries. Connecting Technologies.

OK International Ltd.
Eagle Close, Chandlers Ford
Hampshire, SO50 4NF, U.K.
Tel: +44 (0)23 8048 9100
Fax: +44 (0)23 8048 9109

OK Industries is an OK International Company

OK Industries Inc.
500 Nuber Avenue
Mount Vernon, NY 10550 USA
Tel: +1 (914) 663 0684
Fax: +1 (914) 663 0573

OK International Inc.
1530 O'Brien Drive,
Menlo Park, CA 94025 USA
Tel: +1 (650) 325 3291
Fax: +1 (650) 325 5932

OK International GmbH
Postfach 14 30,
D-64504 Groß-Gerau, Germany
Tel: +49 (0)61 52-71 12-0
Fax: +49 (0)61 52-71 12-22

OK International S.A.
Rue Ampere, Z.I. Lyon Nord
69730 Genay, France
Tel: +33 (0)4 72 08 75 75
Fax: +33 (0)4 72 08 75 70

OK International SPA
Strada Statale 11 - No 28
20010 Vittuone (Milano), Italy
Tel: +39 02 90 25 161
Fax: +39 02 90 11 11 47

OK International (Japan)
1-10-6 Ebisu,
Shibuya-ku, Tokyo,
150-0013, Japan
Tel: +81 3 3449-7451
Fax: +81 3 3440-2010

OK International (Taiwan)
5th Floor, No. 79, Sec 1
Hsin Tai Wu Road, Hsi-Chih
Taipei Hsien, Taiwan, R.O.C.
Tel: +886 (2) 2698-4013
Fax: +886 (2) 2698-4021

OK International (China)
Hua Pu International Plaza,
No. 19 Chao Yang Men Wai Avenue,
Beijing 100020, China
Tel: +86 10-6599-2304
Fax: +86 10-6599-2342

OK Korea (Representative) Co.
5 Fl, Yang Chun Bldg,
330-11 Shin Jung-Dong,
Yang Chun-Ku, Seoul, Korea
Tel: +82 (2) 643-8833
Fax: +82 (2) 643-5539

OK Australia (Representative) PTY Ltd.
Unit 1, 8 Grex Avenue,
Minchinbury 2770, NSW, Australia
Tel: +61 (2) 9832 8052
Fax: +61 (2) 9832 8045