

# QUANTA<sup>®</sup>



**QXXXC AC VOLTAGE  
QXXXD AC CURRENT  
DIGITAL PANEL METER**

Operator's Manual



**NEWPORT** Electronics, Inc.

<http://www.newportUS.com/manuals>



Additional products from  
**NEWPORT** Electronics, Inc.

Counters	Rate Meters
Frequency Meters	Timers
PID Controllers	Totalizers
Clock/Timers	Strain Gauge Meters
Printers	Voltmeters
Process Meters	Multimeters
On/Off Controllers	Soldering Iron Testers
Recorders	pH pens
Relative Humidity	pH Controllers
Transmitters	pH Electrodes
Thermocouples	RTDs
Thermistors	Thermowells
Wire	Flow Sensors

For Immediate Assistance  
In the U.S.A. and Canada: 1-800-NEWPORT®  
In Mexico: (95) 800-NEWPORT<sup>SM</sup>  
Or call your local NEWPORT Office.

**NEWPORTnet<sup>SM</sup> On-Line Service**  
<http://www.newportUS.com>

**Internet e-mail**  
[info@newportUS.com](mailto:info@newportUS.com)

It is the policy of NEWPORT to comply with all worldwide safety and EMC/EMI regulations that apply. NEWPORT is constantly pursuing certification of its products to the European New Approach Directives. NEWPORT will add the CE mark to every appropriate device upon certification.

The information contained in this document is believed to be correct but NEWPORT Electronics, Inc. accepts no liability for any errors it contains, and reserves the right to alter specifications without notice.

**WARNING:** These products are not designed for use in, and should not be used for, patient connected applications.



This device is marked with the international caution symbol. It is important to read the Setup Guide before installing or commissioning this device as it contains important information relating to safety and EMC.

## TABLE OF CONTENTS

SAFETY CONSIDERATIONS .....	ii
Q2000 MAIN ASSEMBLY	
1.0 Specifications .....	1
2.0 Mechanical Assembly and Installation .....	4
3.0 Power & Signal Input Connections .....	5
4.0 Configuration Procedure .....	6
5.0 Configuration Charts .....	7
6.0 Tests and Diagnostics .....	9
7.0 Main Board Connector Pin Assignments .....	10
8.0 Drawings .....	11
Q9000 MAIN ASSEMBLY	
9.0 Specifications .....	17
10.0 Mechanical Assembly and Installation .....	20
11.0 Power & Signal Input Connections .....	21
12.0 Configuration Procedure .....	22
13.0 Configuration Charts .....	23
14.0 Tests and Diagnostics .....	26
15.0 Main Board Connector Pin Assignments .....	27
16.0 Drawings .....	28
SIGNAL CONDITIONER BSCC, BSCC/D	
17.0 Specifications .....	31
18.0 Signal Input Requirements .....	35
19.0 Test and Diagnostics .....	36
20.0 Configuration Procedure .....	37
21.0 Configuration Charts .....	40
22.0 Calibration .....	42
23.0 Drawings .....	43
INSTALLATION INSTRUCTIONS	
24.0 Digital Panel Meter Installation Instructions .....	45
25.0 Signal Input Connections .....	48

## SAFETY CONSIDERATIONS



This device is marked with the international Caution symbol. It is important to read this manual before installing or commissioning this device as it contains important information relating to Safety and EMC (Electromagnetic Compatibility).

### Unpacking & Inspection



Unpack the instrument and inspect for obvious shipping damage. Do not attempt to operate the unit if damage is found.

This instrument is a panel mount device protected in accordance with Class I of EN 61010 (115/230 AC power connections). Installation of this instrument should be done by Qualified personnel. In order to ensure safe operation, the following instructions should be followed.

This instrument has no power-on switch. An external switch or circuit-breaker shall be included in the building installation as a disconnecting device. It shall be marked to indicate this function, and it shall be in close proximity to the equipment within easy reach of the operator. The switch or circuit-breaker shall not interrupt the Protective Conductor (Earth wire), and it shall meet the relevant requirements of IEC 947-1 and IEC 947-3 (International Electrotechnical Commission). The switch shall not be incorporated in the mains supply cord.

Furthermore, to provide protection against excessive energy being drawn from the mains supply in case of a fault in the equipment, an overcurrent protection device shall be installed.



- The **Protective Conductor** must be connected for safety reasons. Check that the power cable has the proper Earth wire, and it is properly connected. It is not safe to operate this unit without the Protective Conductor Terminal connected.



- Do not exceed voltage rating on the label located on the top of the instrument housing.
- Always disconnect power before changing signal and power connections.
- Do not use this instrument on a work bench without its case for safety reasons.
- Do not operate this instrument in flammable or explosive atmospheres.
- Do not expose this instrument to rain or moisture.
- Unit mounting should allow for adequate ventilation to ensure instrument does not exceed operating temperature rating.
- Use electrical wires with adequate size to handle mechanical strain and power requirements. Install without exposing bare wire outside the connector to minimize electrical shock hazards.

### EMC Considerations

- Whenever EMC is an issue, always use shielded cables.
- Never run signal and power wires in the same conduit.
- Use signal wire connections with twisted-pair cables.
- Install Ferrite Bead(s) on signal wires close to the instrument if EMC problems persist.

## 1.0 MAIN ASSEMBLY Q2000 SPECIFICATIONS

### 1.1 GENERAL

The Q2000 main assemblies are identified by an initial designator (BQ2) plus a power/display option numeral, zero thru nine (0-9).

The following table identifies the main assembly types:

Display Type	120 V ac	240 V ac	9-32 V dc	5 V ac	24 V ac
LED	BQ20	BQ22	BQ24	BQ26	BQ28
LCD	BQ21	BQ23	BQ25	BQ27	BQ29

The QUANTA Digital Panel Meter/Controller consists of a main assembly, signal conditioner and interface options (if ordered) all housed in a 1/8 DIN case.

The main assembly consists of a main board and a display board which is permanently attached to it at a 90 degree angle.

The main board provides mounting for the power supply, circuit components, and connectors for plugging in the signal conditioner, optional analog card, and optional controller/communications interface card (requires removal of a bypass push-on jumper).

The display board includes the analog-to-digital converter, the LED or LCD display and the push-on jumper for programming the decimal points. Decimal point programming may also be done from the main board connector (J1).

## 1.2 POWER

AC Models:	24/120/240 V +10/-15% 47-63 Hz
Common Mode Voltage:	1500 Vp test (354 Vp per IEC spacing), (150 Vp per CE)
DC Models:	5 V $\pm$ 5% (5 V return common to signal LO) 9-32 V (300 V isolation from 9-32 V return to signal LO) (100 Vp per CE)
Source Impedance:	3 ohms
Ripple:	250 mV maximum
Power Consumption:	5 watts maximum

## 1.3 DISPLAY

LED:	14.2 mm (0.56 in), 7-segment light emitting diode
Lens color:	Red
LCD:	12.7 mm (0.50 in), 7-segment liquid crystal
Lens color:	Clear
Range:	0 to $\pm$ 1999
Overload Indication:	Three least significant digits blanked, "1" or "-1" displayed

## 1.4 CONVERSION

Technique:	auto-zero, dual slope, average value
Signal Integration Period:	100 ms, nominal
Reading Rate:	2.5/s, nominal

## 1.5 ENVIRONMENTAL

Operating Temperature (Ambient):	0 to 60°C
Storage Temperature:	-40 to 85°C
Humidity:	To 95% RH, non-condensing, 0-40°C

## 1.6 MECHANICAL

Case Material:	UL-rated 94V-0, polycarbonate
Weight:	0.57 kg (with interface board)

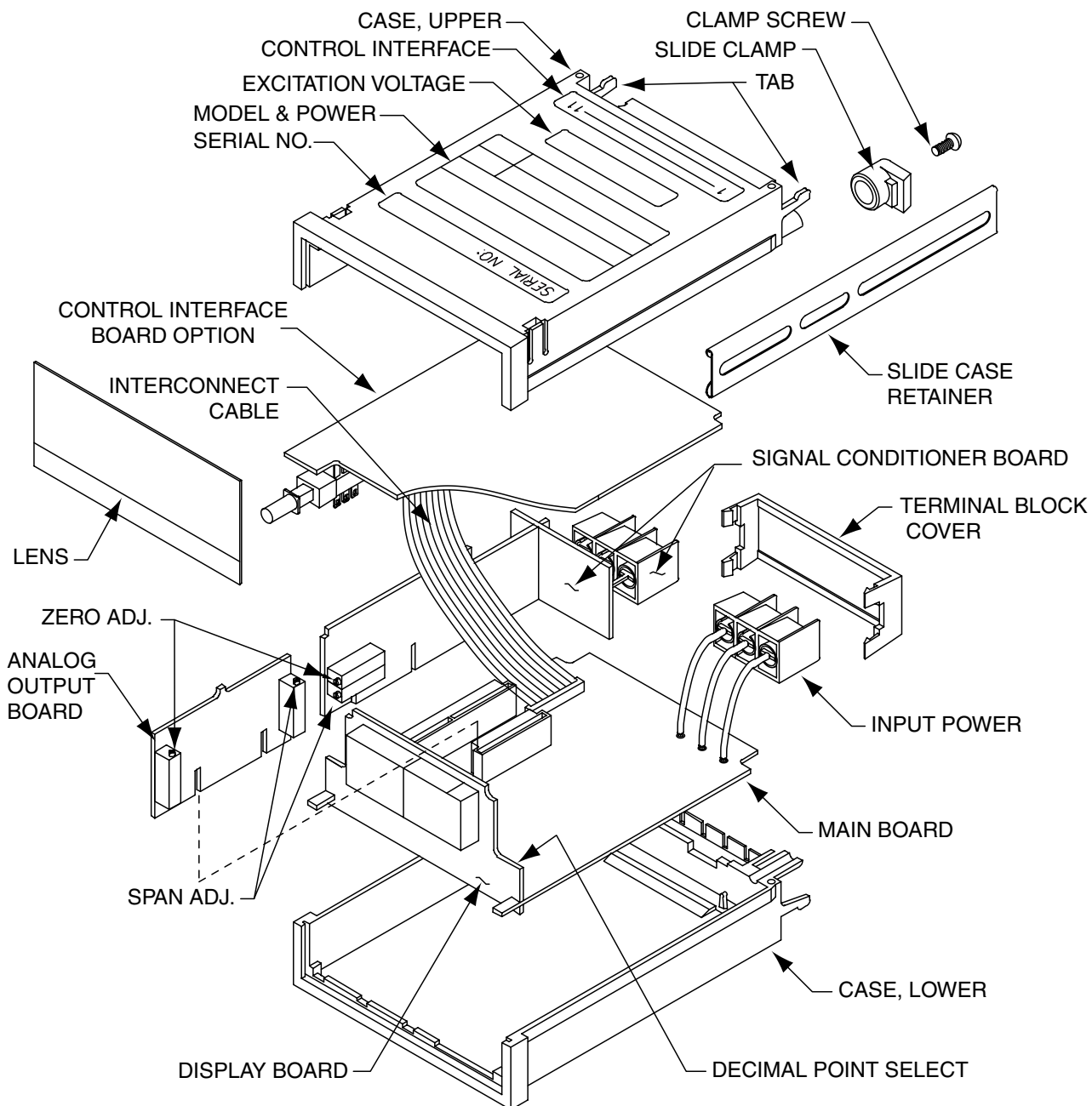

## 2.0 MECHANICAL ASSEMBLY & INSTALLATION

### 2.1 PANEL MOUNTING PROCEDURE (SEE FIGURE 1)

1. Remove the main board edge connector (J1), if installed.
2. Remove the interface board connector (J2), if installed.
3. Loosen two clamp screws on the rear of the case enough to rotate the two slide clamps.
4. Slide the two slide retainers toward the rear of the case and remove them.
5. From the front of the panel, insert the meter into the panel cutout.
6. Slide the slide retainers back onto the case and push up tightly against the rear of the panel.
7. Rotate the slide clamps back into their original position and tighten enough to hold the case in place. Overtightening can break the clamps.
8. Install any connectors removed.

### 2.2 LABELS (SEE FIGURE 2)

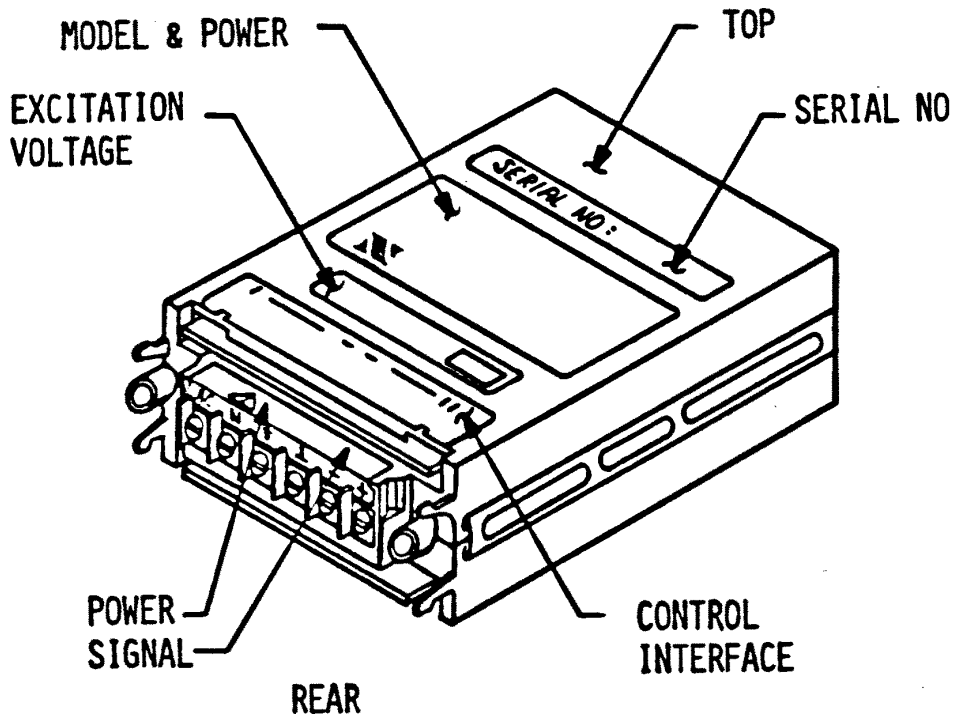

NOTE: READ LABELS FROM THE REAR

FIGURE 2. LABEL PLACEMENT



### 3.0 POWER & SIGNAL INPUT CONNECTIONS

**WARNING: Incorrect power input can damage your QUANTA PANEL METER**

#### 3.1 POWER CONNECTIONS

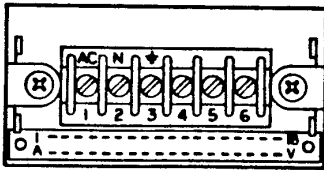

REAR TERMINAL VIEW

Terminal Connection	AC Versions	Wire Color
1	AC power HI	Black
2	AC power LO (neutral)	White
3	AC power GND	Green

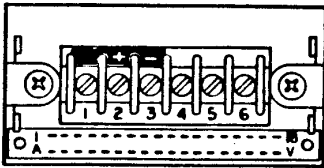

Terminal Connection	DC Versions
1	No connection
2	DC power +
3	DC power - (return)

#### 3.2 SIGNAL INPUT CONNECTIONS

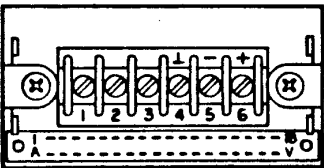

REAR TERMINAL VIEW

Terminal Connection	6 Terminal Versions Signal
4	Analog GND
5	Signal LO
6	Signal HI

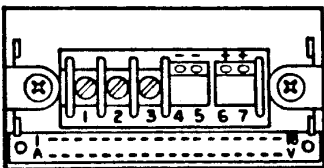

Terminal Connection	7 Terminal Versions Signal
4	-E (Excitation return)
5	-S (Signal LO input)
6	+S (Signal HI input)
7	+E (Excitation output)

#### **4.0 CONFIGURATION PROCEDURE**

This procedure is used to set the decimal point of the display and interface board signal bypass selections for the configuration of the QUANTA Q2XXXX Display and power options (BQ20 through BQ29).

The main assembly can be configured using the push-on jumpers provided or already positioned on the pin forests. Pin forest designations are shown at the top of every page of the configuration charts.

## 5.0 CONFIGURATION CHARTS

### 5.1 DECIMAL POINT SELECTION

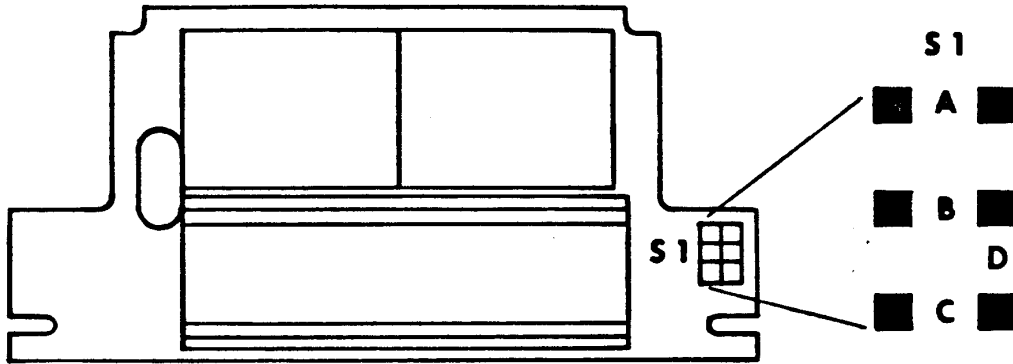

Step 1: Remove all push-on jumpers not used in the desired configuration(s).		
Step 2: Select the desired configuration from the chart below, then install the push-on jumpers indicated.		
Decimal Point Selection	S1	Alternate Decimal Point Selection Using Main Assembly Board (J1) Connector
Decimal Point (1.999)	A	Connect J1-K/9 to J1-6
Decimal Point (19.99)	B	Connect J1-J/8 to J1-6
Decimal Point (199.9)	C	Connect J1-H/7 to J1-6
No Decimal Point (1999)	D	No Connection

## 5.2 INTERFACE BOARD SIGNAL BYPASS SELECTION

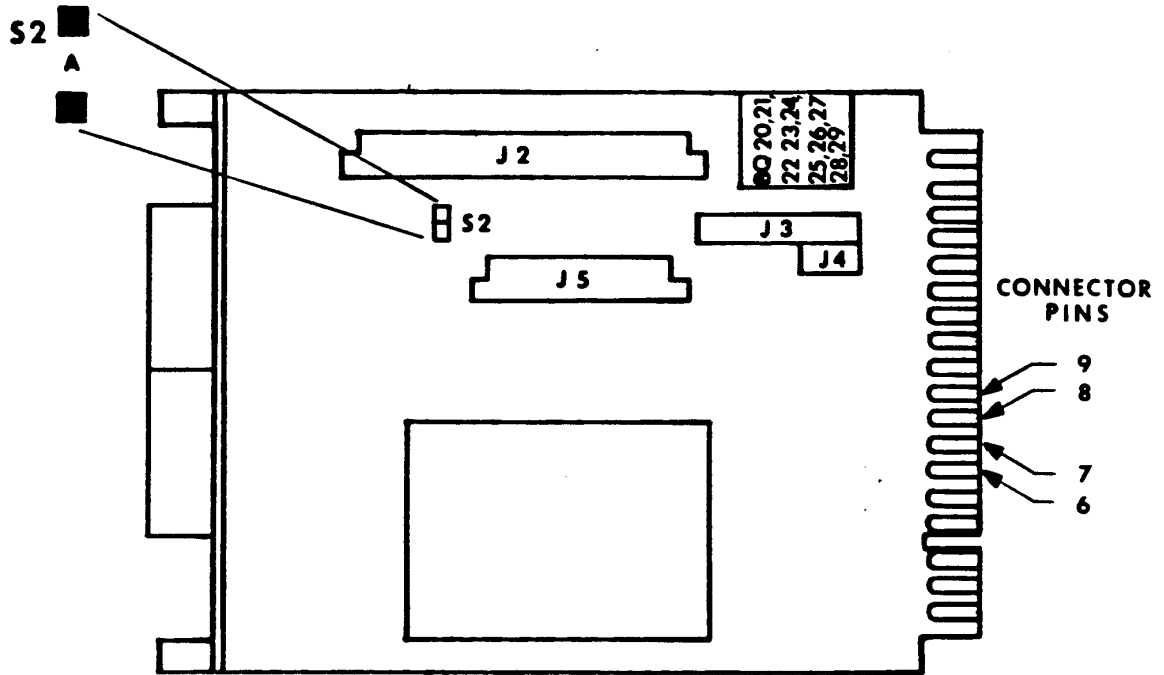

Step 1: Check your QUANTA part number for a zero (0) in the following position; Q2XX0X. If there is a zero (0) in that position, interface board signal bypass is required.	
Step 2: Remove all push-on jumpers not used in the desired configuration(s).	
Step 3: Select the desired configuration from the chart below, then install the push-on jumpers indicated.	
Interface Board Signal Configuration	S2
Interface Board Signal Bypass	A

## **6.0 TESTS & DIAGNOSTICS**

### **6.1 TEST CONFIGURATION REQUIREMENTS**

The QUANTA main assembly is designed to function with a signal conditioner board as a minimum configuration. There is no provision for testing a main assembly alone.

### **6.2 SIGNAL INPUT REQUIREMENTS**

Signal input requirements for your configuration are identified in the signal conditioner section of this manual.

**7.0 MAIN BOARD CONNECTOR PINOUTS (J1)**  
 (Left to right, looking at rear of case)

<u>Connection</u>	<u>Function</u>	
A - 1	Spare	
B	Oscillator	40 kHz
2	-8.2 V dc	Analog power
C - 3	Spare	
D	+ Pol (sign)	+ Polarity sign
4	HOLD	LED version only
E - 5	Spare	
F	Buffer	Integrator output
6	Digital Ground	
H - 7	199.9 (Decimal point)	Use with pin 6
J - 8	19.99 (Decimal point)	Use with pin 6
K - 9	1.999 (Decimal point)	Use with pin 6
L - 10	Test (LED version only)	Use with pin M/11
M - 11	+5 V dc	Analog & digital power
N - 12	Analog output	Standard 1 mV/count
P - 13	Spare	
R - 14	Spare	Used with H & S options - Excitation sense
S - 15	Analog Ground	
T - 16	Analog Option - Return	Used with analog option
U	Analog Option - Out	Used with analog option
17	+30 V dc	Unregulated power
V - 18	Spare	Used with S option + Excitation sense
-	Indicates common pin.	
	50 mA maximum power available from all internal sources.	

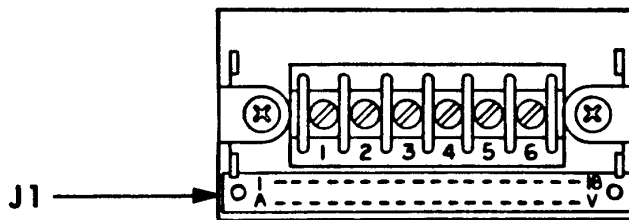

REAR TERMINAL VIEW

## 8.0 DRAWINGS

### 8.1 DIMENSIONS

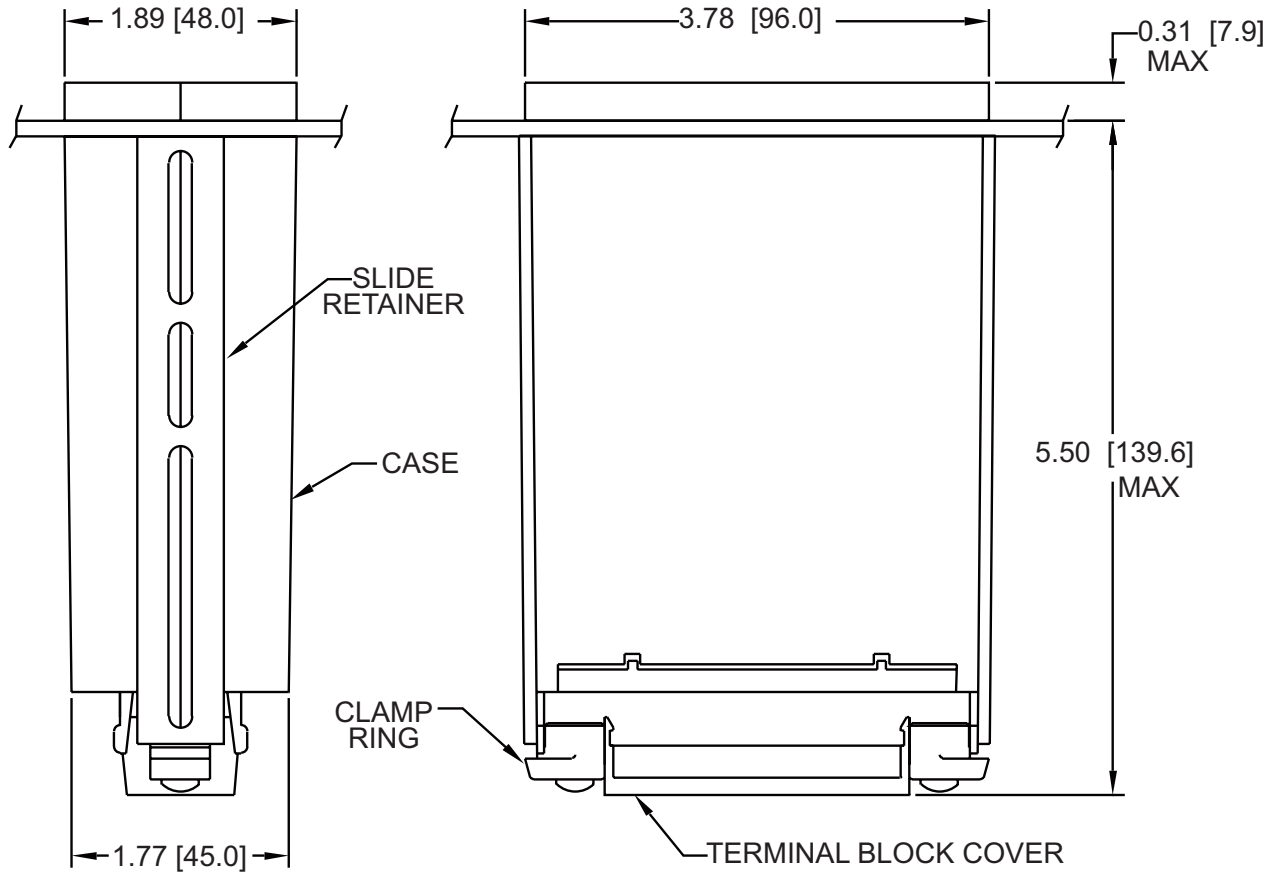

Notes: Dimensions are in inches  $\pm 0.01$ "  
with millimeters in [ ]  $\pm 0.25$  mm.

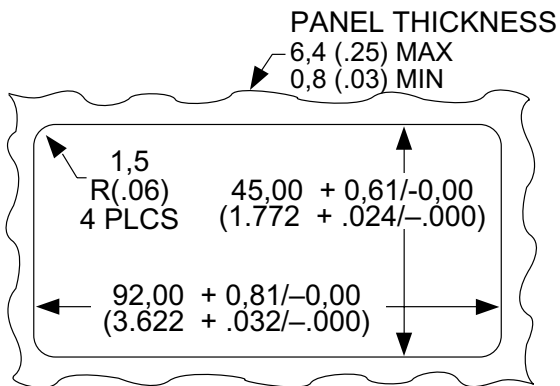

NOTE: Dimensions in Millimeters (Inches)

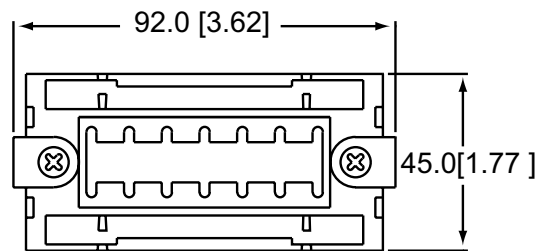

#### REAR VIEW

(TERMINAL BLOCK COVER AND  
BEZEL NOT SHOWN FOR CLARITY)  
SLIDE CLAMPS ROTATED AND SLIDE RETAINERS  
REMOVED AS SHOWN FOR INSTALLATION.

8.2 Q2000 LED MAIN ASSEMBLY

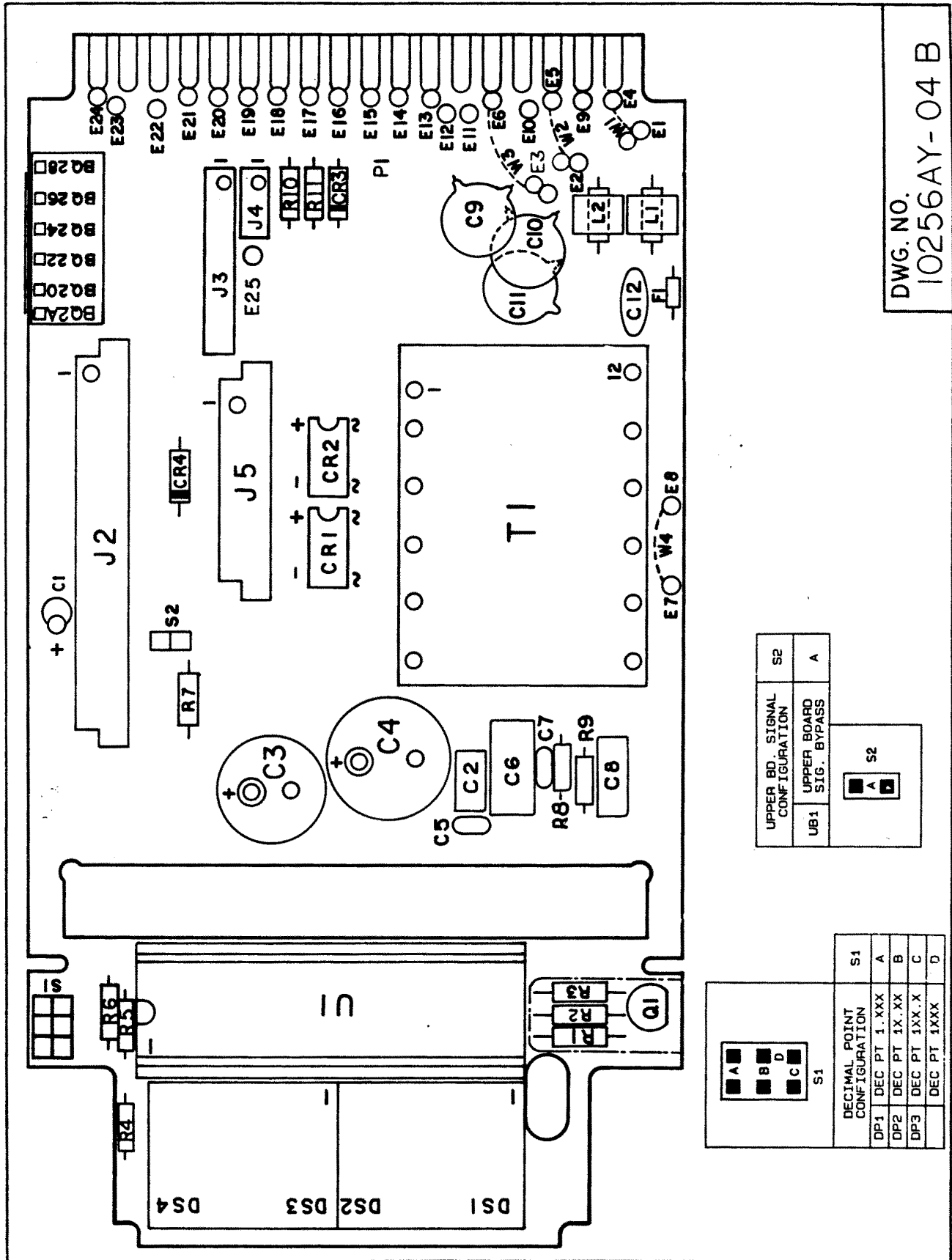

DWG. NO.  
10256AY-04 B

UPPER BD. SIGNAL CONFIGURATION		S2
UB1	UPPER BOARD SIG. BYPASS	A

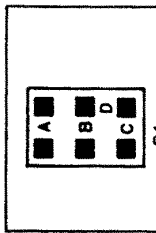
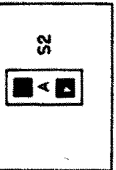

DECIMAL POINT CONFIGURATION		S1
DP1	DEC PT 1.XXX	A
DP2	DEC PT 1X.XX	B
DP3	DEC PT 1XX.X	C
	DEC PT 1XXX	D



## NOTES

8.4 Q2000 LCD MAIN ASSEMBLY

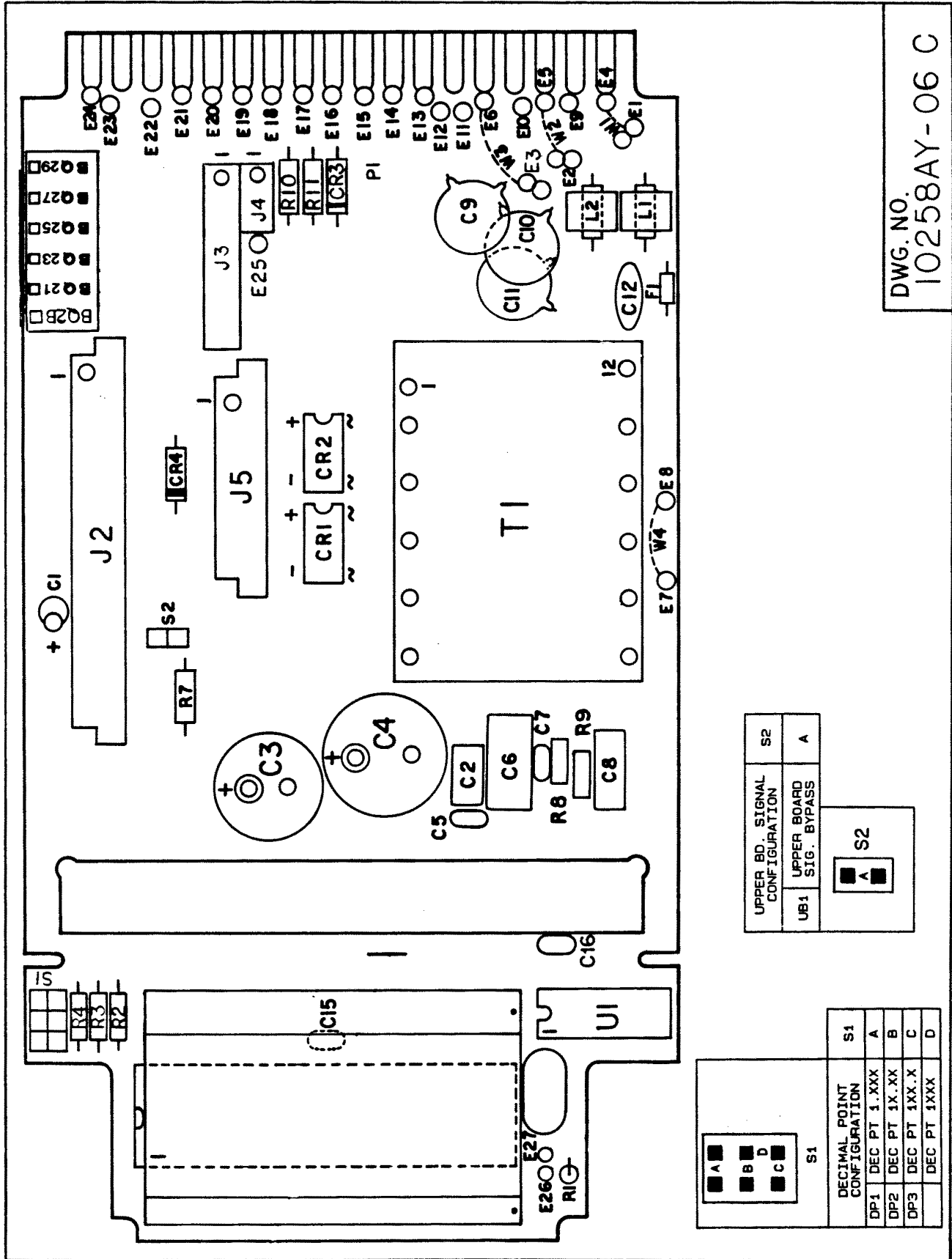

DWG. NO.  
10258AY-06 C

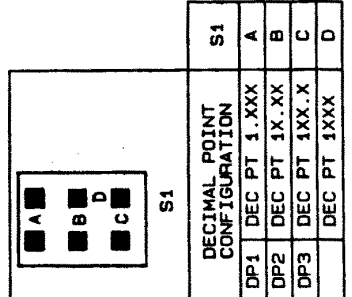
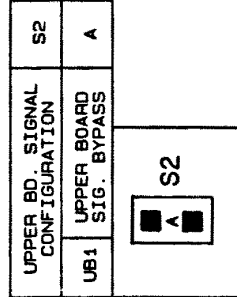

## NOTES

## NOTES

## 9.0 MAIN ASSEMBLY Q9000 SPECIFICATIONS

### 9.1 GENERAL

The Q9000 main assemblies are identified by an initial designator (BQ9) plus a power/display option number: 0, 2, 4, 6, or 8.

The following table identifies the main assembly types:

Display Type	120 V ac	240 V ac	9-32 V dc	5 V ac	24 V ac
LED	BQ90	BQ92	BQ94	BQ96	BQ98

The QUANTA Digital Panel Meter/Controller consists of a main assembly, signal conditioner and interface options (if ordered) all housed in a 1/8 DIN case.

The main assembly consists of a main board and a display board which is permanently attached to it at a 90 degree angle.

The main board provides mounting for the power supply, circuit components, and connectors for plugging in the signal conditioner, optional analog card, and optional controller/communications interface card (requires removal of a bypass push-on jumper).

The display board includes the analog-to-digital converter, the LED and the push-on jumper for programming the decimal points. Decimal point programming may also be done from the main board connector (J1).

## 9.2 POWER

AC Models:	24/120/240 V +10/-15% 47-63 Hz
Common Mode Voltage:	1500 Vp test (354 Vp per IEC spacing),
DC Models:	5 V $\pm$ 5% (5 V return common to signal LO) 9-32 V (300 V isolation from 9-32 V return to signal LO) (100 Vp per CE)
Source Impedance:	3 ohms
Ripple:	250 mV maximum
Power Consumption:	5 watts maximum

## 9.3 DISPLAY

LED:	14.2 mm (0.56 in), 7-segment light emitting diode
Lens color:	Red
Range:	0 to $\pm$ 9999, digits flash from 10K to 20K counts
Overload Indication:	Four digits flash zero at 20K and above

## 9.4 CONVERSION

Technique:	auto-zero, dual slope, average value
Signal Integration Period:	100 ms, nominal
Reading Rate:	2.5/s, nominal

## 9.5 ENVIRONMENTAL

Operating Temperature (Ambient):	0 to 60°C
Storage Temperature:	-40 to 85°C
Humidity:	To 95% RH, non-condensing, 0-40°C

## 9.6 MECHANICAL

Case Material:	UL-rated 94V-0, polycarbonate
Weight:	0.57 kg (with interface board)

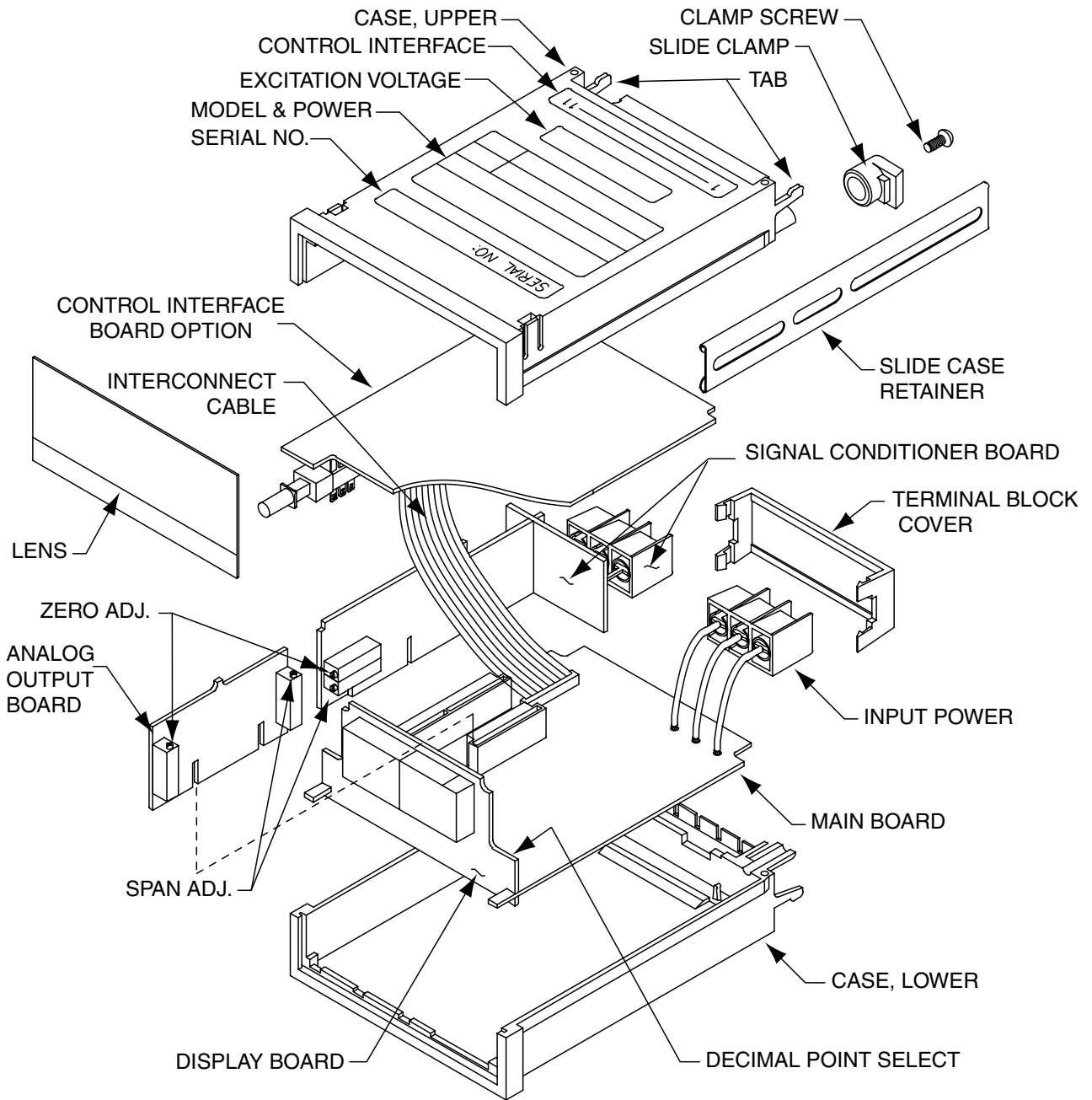

## 10.0 MECHANICAL ASSEMBLY & INSTALLATION

### 10.1 PANEL MOUNTING PROCEDURE (SEE FIGURE 3)

1. Remove the main board edge connector (J1), if installed.
2. Remove the interface board connector (J2), if installed.
3. Loosen two clamp screws on the rear of the case enough to rotate the two slide clamps.
4. Slide the two slide retainers toward the rear of the case and remove them.
5. From the front of the panel, insert the meter into the panel cutout.
6. Slide the slide retainers back onto the case and push up tightly against the rear of the panel.
7. Rotate the slide clamps back into their original position and tighten enough to hold the case in place. Overtightening can break the clamps.
8. Install any connectors removed.

### 10.2 LABELS (SEE FIGURE 4)

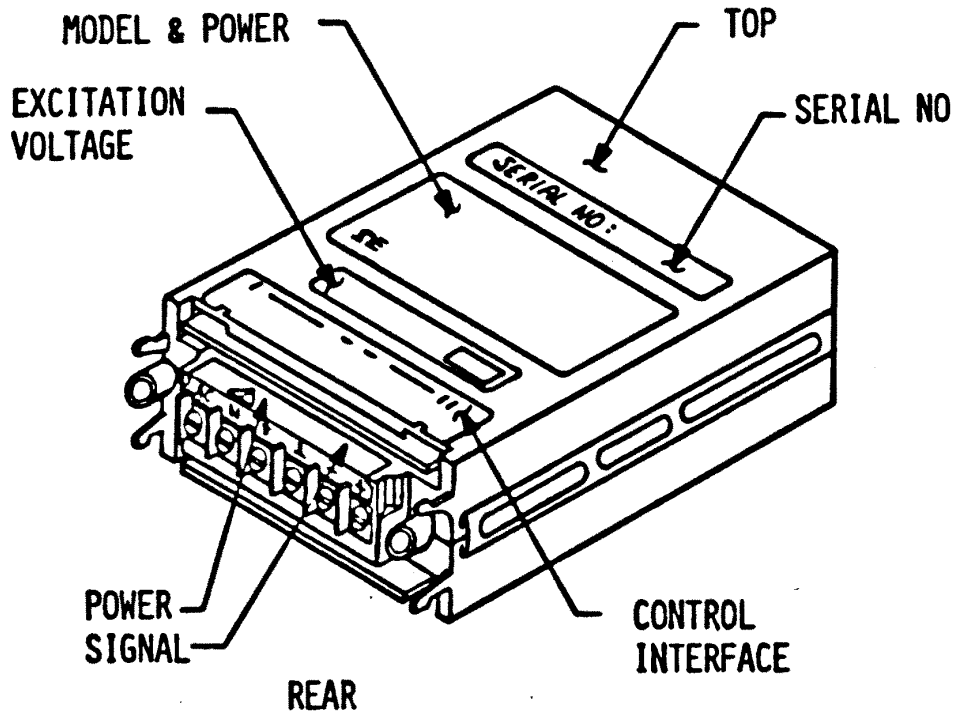

NOTE: READ LABELS FROM THE REAR

FIGURE 4. LABEL PLACEMENT



## 11.0 POWER & SIGNAL INPUT CONNECTIONS

**WARNING: Incorrect power input can damage your QUANTA PANEL METER.**

### 11.1 POWER CONNECTIONS

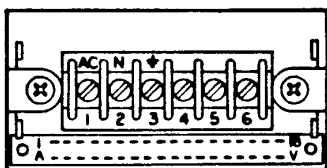

REAR TERMINAL VIEW

Terminal Connection	AC Versions	Wire Color
1	AC power HI	Black
2	AC power LO (neutral)	White
3	AC power GND	Green

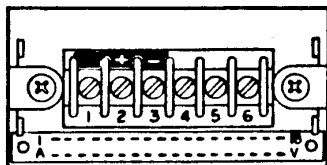

Terminal Connection	DC Versions
1	No connection
2	DC power +
3	DC power - (return)

### 11.2 SIGNAL INPUT CONNECTIONS

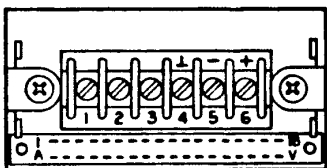

REAR TERMINAL VIEW

Terminal Connection	6 Terminal Versions Signal
4	Analog GND
5	Signal LO
6	Signal HI

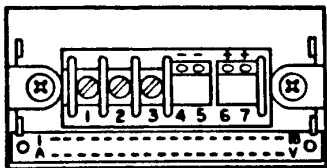

Terminal Connection	7 Terminal Versions Signal
4	-E (Excitation return)
5	-S (Signal LO input)
6	+S (Signal HI input)
7	+E (Excitation output)

## 12.0 CONFIGURATION PROCEDURE

This procedure is used to set the decimal point of the display and interface board signal bypass selections for the configuration of the QUANTA Q9XXXX display and power options (BQ90 through BQ98).

The main assembly can be configured using the push-on jumpers provided or already positioned on the pin forests. Pin forest designations are shown at the top of every page of the configuration charts.

## 13.0 CONFIGURATION CHARTS

### 13.1 DECIMAL POINT SELECTION

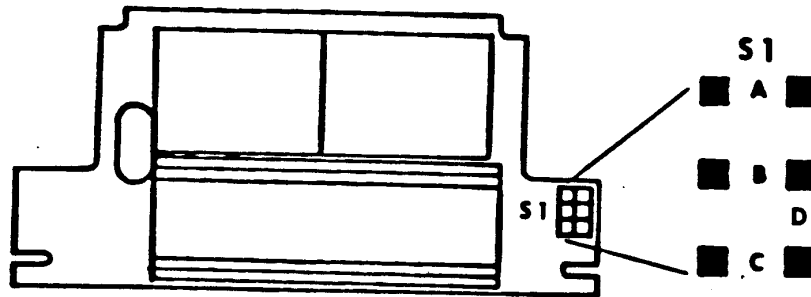

Step 1: Remove all push-on jumpers not used in the desired configuration(s).		
Step 2: Select the desired configuration from the chart below, then install the push-on jumpers indicated.		
Decimal Point Selection	S1	Alternate Decimal Point Selection Using Main Assembly Board (J1) Connector
Decimal Point (9.999)	A	Connect J1-K/9 to J1-6
Decimal Point (99.99)	B	Connect J1-J/8 to J1-6
Decimal Point (999.9)	C	Connect J1-H/7 to J1-6
No Decimal Point (9999)	D	No connection

### 13.2 INTERFACE BOARD SIGNAL BYPASS SELECTION

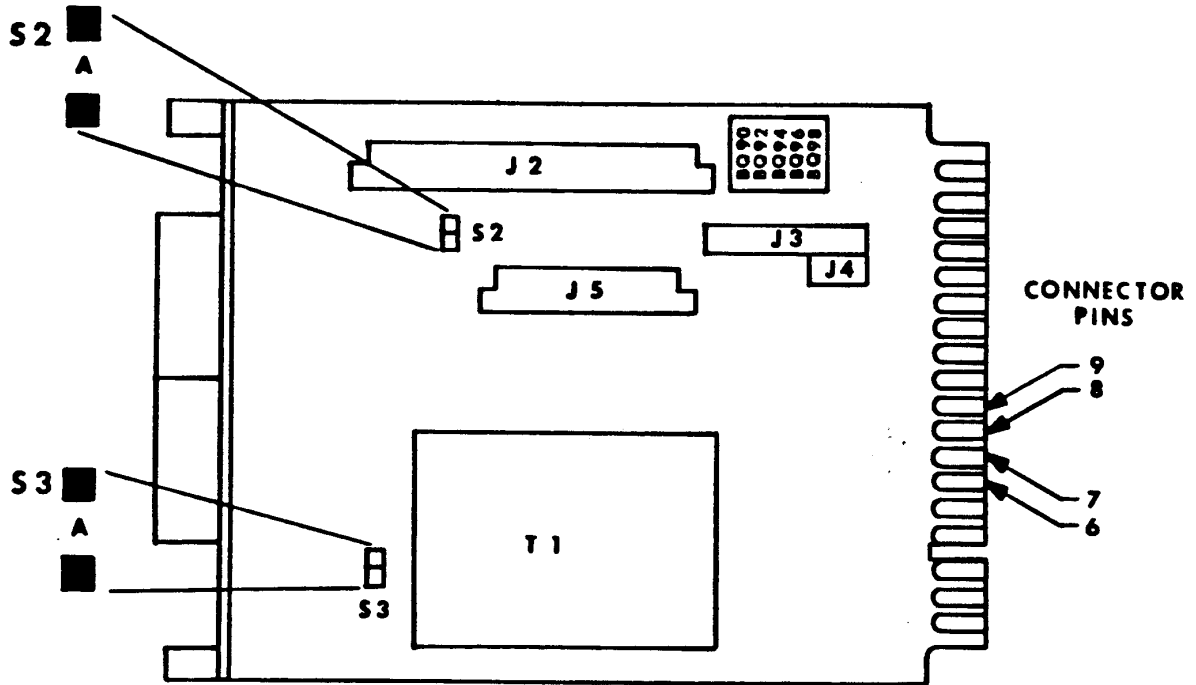

Step 1: Check your QUANTA part number for a zero (0) in the following position; Q9XX0X. If there is a zero (0) in that position, interface board signal bypass is required.	
Step 2: Remove all push-on jumpers not used in the desired configuration(s).	
Step 3: Select the desired configuration from the chart below, then install the push-on jumpers indicated.	
Interface Board Signal Configuration	S2
Interface Board Signal Bypass	A

### 13.3 REFERENCE VOLTAGE (RV1, RV2)

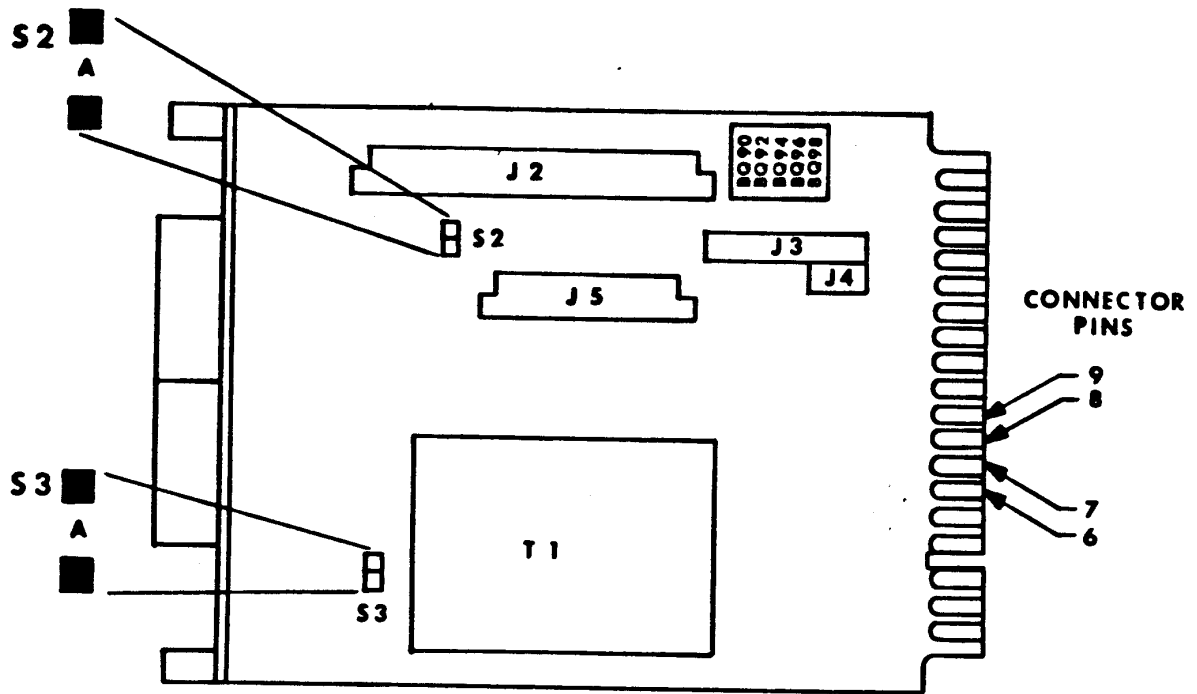

Step 1: Remove all push-on jumpers not used in the desired configuration(s).		
Step 2: Select the desired configuration from the chart below, then install the push-on jumpers indicated.		
Reference Voltage Configuration		S3
RV1	1 Volt	A
RV2	2 Volts	-

## 14.0 TESTS & DIAGNOSTICS

### 14.1 TEST CONFIGURATION REQUIREMENTS

The QUANTA main assembly is designed to function with a signal conditioner board as a minimum configuration. There is no provision for testing a main assembly alone.

### 14.2 SIGNAL INPUT REQUIREMENTS

Signal input requirements for your configuration are identified in the signal conditioner section of this manual.

**15.0 MAIN BOARD CONNECTOR PINOUTS (J1)**  
 (Left to right, looking at rear of case)

Connection	Function	
A - 1	Spare	
B	Oscillator	100 kHz
2	-8.2 V dc	Analog power
C - 3	Spare	
D	+ Pol (sign)	+ Polarity sign
4	HOLD	LED version only
E 5	Spare	
F	Buffer	Integrator output
6	Digital Ground	
H - 7	XXX.X (Decimal point)	Use with pin 6
J - 8	XX.XX (Decimal point)	Use with pin 6
K - 9	X.XXX (Decimal point)	Use with pin 6
L - 10	TEST	Use with pin M/11
M - 11	+5 V dc	Analog & digital power
N - 12	Analog output	Standard 1 mV/count
P 13	Spare	
R	Spare	
14		Used with H & S options - Excitation sense
S - 15	Analog Ground	
T - 16	Analog Option - Return	Used with analog option
U	Analog Option - Out	Used with analog option
17	+30 V dc	Unregulated power
V - 18	Spare	Used with S option
-	Indicates common pin	50 mA maximum power available from all internal sources.

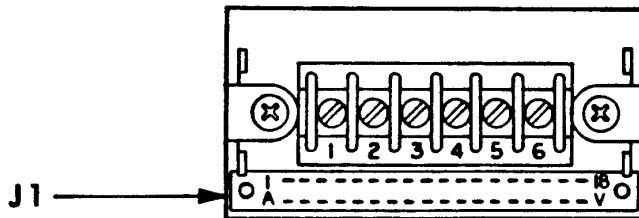

REAR TERMINAL VIEW

# 16.0 DRAWINGS

## 16.1 DIMENSIONS

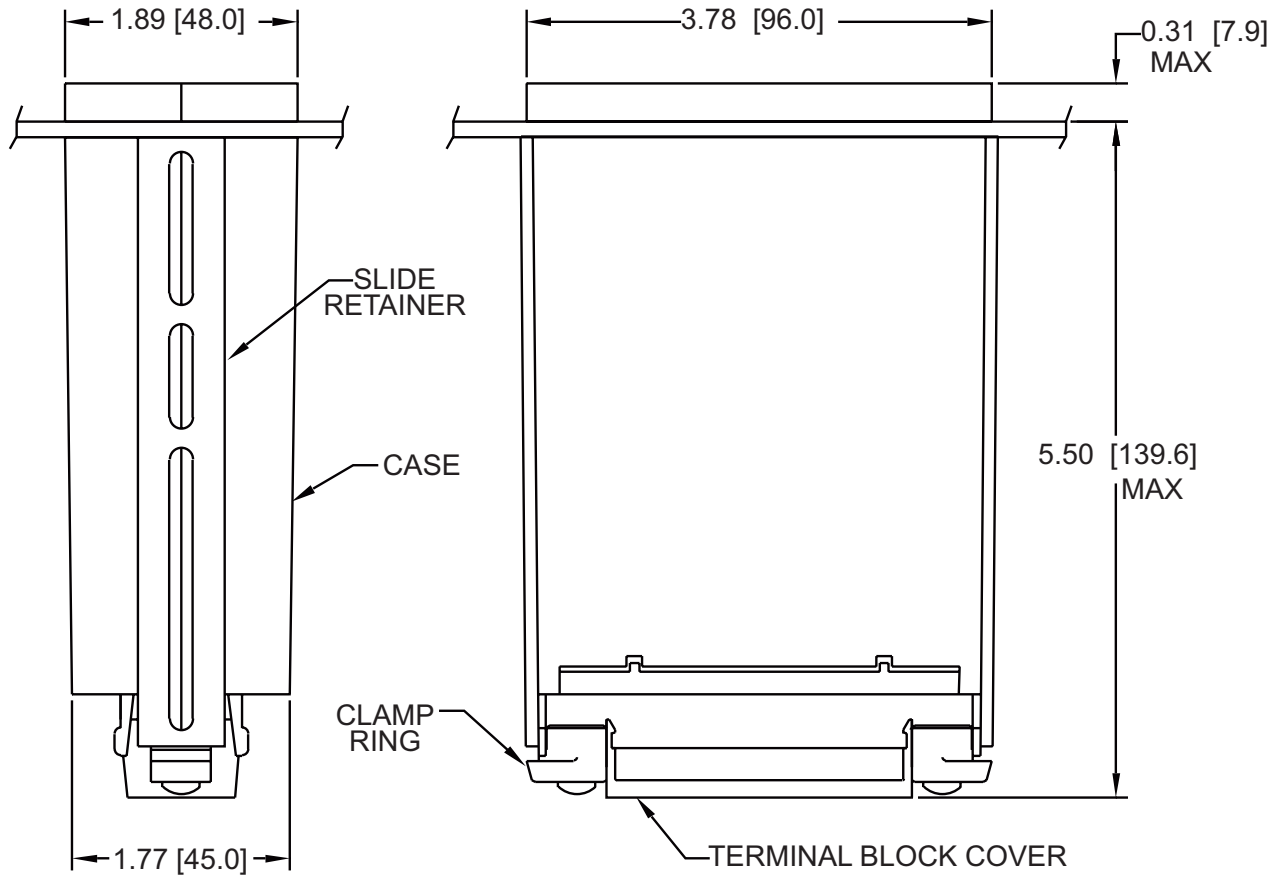

Notes: Dimensions are in inches  $\pm 0.01''$   
with millimeters in [ ]  $\pm 0.25$  mm.

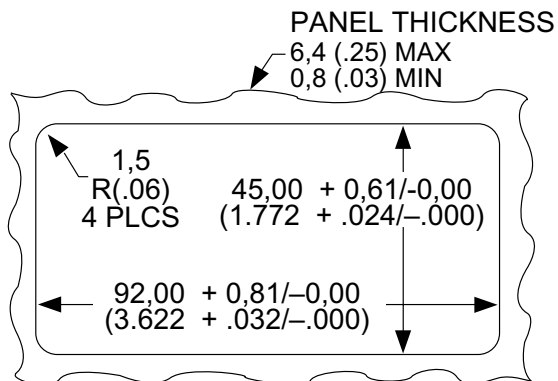

NOTE: Dimensions in Millimeters (Inches)

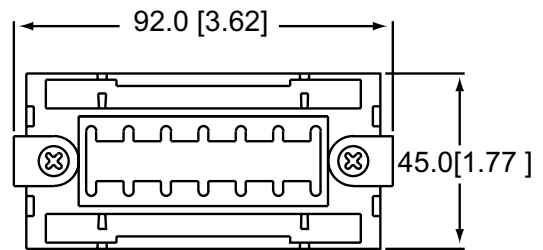

### REAR VIEW

(TERMINAL BLOCK COVER AND BEZEL NOT SHOWN FOR CLARITY)  
SLIDE CLAMPS ROTATED AND SLIDE RETAINERS REMOVED AS SHOWN FOR INSTALLATION.



16.2 Q9000 LED MAIN ASSEMBLY

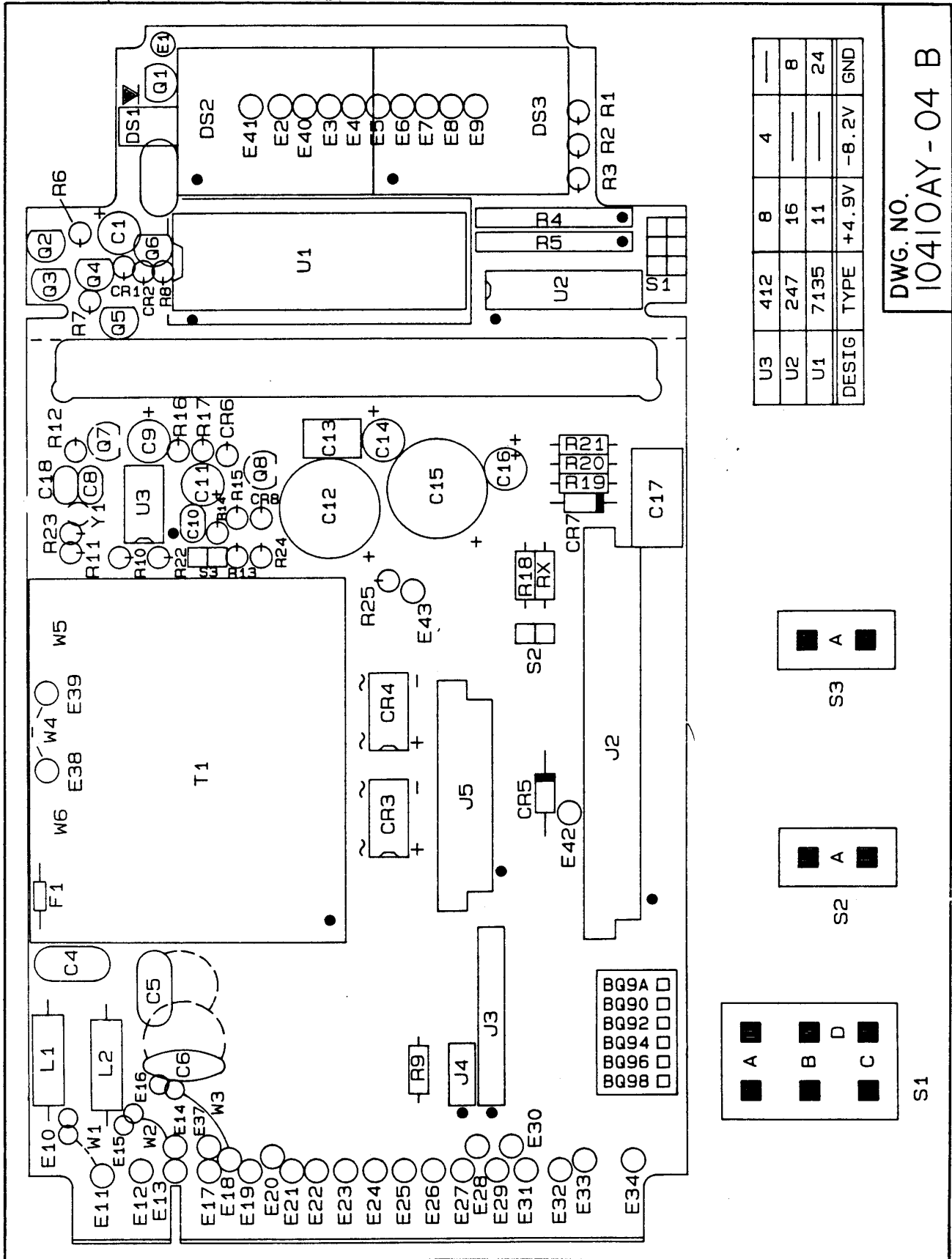

DWG. NO.  
10410AY-04 B

## NOTES

## 17.0 SPECIFICATIONS

### 17.1 GENERAL

The basic signal conditioner board is identified as a BSCC (Q2000C or Q9000C) for ac voltage input. The Q2000 and Q9000 prefix is determined by the main assembly board used with the BSCC option board. When the BSCC board is configured differently, it is identified as a BSCC/D (Q2000D or Q9000D), used for ac current input.

### 17.2 BSCC: AC VOLTAGE SIGNAL CONDITIONER

Five full-scale ranges are provided in the Q2000C and Q9000C series. The reading is computed from the rectified ac signal, calibrated for sinusoidal input. See AC VOLTAGE INPUT tables on pages 33 and 34.

### 17.3 BSCC/D: AC CURRENT SIGNAL CONDITIONER

Ten full-scale ranges are provided in this series. The reading is computed from the rectified ac signal, calibrated for sinusoidal input. See AC CURRENT INPUT tables on pages 35.

### 17.4 Q2000C & Q9000C: AC VOLTAGE INPUT SPECIFICATIONS

Configuration: Single-ended, meter ground common to signal LO

Zero: Automatic

#### Q2000C AC VOLTAGE INPUTS

RANGE	INPUT IMPEDANCE	RESOLUTION	FREQUENCY RANGE
199.9 mV	1.1 M ohm	0.1 mV	47-1000 Hz
1.999 V	1.1 M ohm	1 mV	47-1000 Hz
19.99 V	1 M ohm	10 mV	47-1000 Hz
199.9V	1 M ohm 150.0 V for CE	100 mV	47-1000 Hz
750 V	10 M ohm 150 V for CE	1V	47-1000 Hz

Full-wave rectified ac signal, calibrated for sinusoidal input.

### Q9000C AC VOLTAGE INPUTS

RANGE	INPUT IMPEDANCE	RESOLUTION	FREQUENCY RANGE
99.99 mV	1.1 MOhm	10 uV	47-100 Hz
999.9 mV	1.1 MOhm	100 uV	
9.999 V	1 MOhm	1 mV	
99.99 V	1 MOhm	10 mV	
750.0 V	10 MOhm	100 mV	

#### Common Mode

Analog ground to ac power ground

CMR at dc to 60 Hz 120 dB

CMV at dc to 60 Hz  $\pm 1500$  Vp per HV test  
 $\pm 354$  Vp per IEC spacing

#### Accuracy at 25°C

Maximum Error  
 Q2000C  $\pm 0.05\%$  R  $\pm 1$  count  
 Q9000C  $\pm 0.1\%$  R  $\pm 10$  counts

Reading Tempco  $\pm 0.01\%$  R/°C

Zero Tempco  $\pm 0.1$  count/°C

Warmup to rated accuracy Less than 1 minute

#### Q2000D & Q9000D: AC CURRENT SPECIFICATIONS

Configuration Single-ended, meter ground common to signal LO

Zero Automatic

### Q2000D AC CURRENT INPUTS

RANGE	INPUT IMPEDANCE (200 mV SHUNT)	RESOLUTION	FREQUENCY RANGE
19.99 $\mu$ A	10 kOhms	0.01 $\mu$ A	47-1000 Hz
199.9 $\mu$ A	1 kOhms	0.1 $\mu$ A	
1.999 mA	100 ohms	1 $\mu$ A	
19.99 mA	10 ohms	10 $\mu$ A	
199.9 mA	1 ohm	100 $\mu$ A	
1.999 A	0.1 ohm	1 mA	
5.00 A*	0.01 ohm	2.5 mA	
19.99 A	5 A CT	10 mA	
199.9 A	5 A CT	100 mA	
1999 A	5 A CT	1 A	

\* 50mV shunt for 5 A current transformer input.

### Q9000D AC CURRENT INPUTS

RANGE	INPUT IMPEDANCE (200 mV SHUNT)	RESOLUTION	FREQUENCY RANGE
9.999 $\mu$ A	10 kOhms	1 nA	47-1000 Hz
99.99 $\mu$ A	1 kOhm	10 nA	
0.9999 mA	100 ohms	100 nA	
9.999 mA	10 ohms	1 $\mu$ A	
99.99 mA	1 ohm	10 $\mu$ A	
0.9999 A	0.1 ohm	100 $\mu$ A	
5.00 A*	0.01 ohm	500 $\mu$ A	
9.999 A	5 A CT	1 mA	
99.99 A	5 A CT	10 mA	
999.9 A	5 A CT	100 mA	

Full-wave rectified ac signal, calibrated from sinusoidal input.

\* 50 mV shunt for 5 A current transformer input with main board reference of 2 V.

**Q2000D SPECIAL FULL-SCALE COUNTS (50 mV or 5 A full-scale)**

<u>COUNT RANGE</u>	<u>R16 (1%)</u>	<u>COUNT RANGE</u>	<u>R16 (1%)</u>
1900 to 2100	-	525 to 575	15.4 kOhm
1720 to 1900	523 kOhm	475 to 525	13.3 kOhm
1560 to 1720	215 kOhm	435 to 475	11.8 kOhm
1415 to 1560	130 kOhm	390 to 435	10.5 kOhm
1285 to 1415	93.1 kOhm	355 to 390	8.87 kOhm
1165 to 1285	69.8 kOhm	325 to 355	7.87 kOhm
1055 to 1165	53.6 kOhm	295 to 325	6.98 kOhm
955 to 1055	47.5 kOhm	270 to 295	6.04 kOhm
860 to 955	38.3 kOhm	250 to 270	5.49 kOhm
775 to 860	29.4 kOhm	230 to 250	4.87 kOhm
700 to 775	24.3 kOhm	210 to 230	4.42 kOhm
635 to 700	20.5 kOhm	190 to 210	3.83 kOhm
575 to 635	18.2 kOhm		

**Q9000D SPECIAL FULL-SCALE COUNTS (5 A full-scale)**

<u>COUNT RANGE</u>	<u>R16 (1%)</u>	<u>COUNT RANGE</u>	<u>R16 (1%)</u>
9500 to 10500	-	2625 to 2875	15.4 kOhm
8600 to 9500	523 kOhm	2375 to 2625	13.3 kOhm
7800 to 8600	215 kOhm	2175 to 2375	11.8 kOhm
7075 to 7800	130 kOhm	1950 to 2175	10.5 kOhm
6425 to 7075	93.1 kOhm	1775 to 1950	8.87 kOhm
5825 to 6425	69.9 kOhm	1625 to 1775	7.87 kOhm
5275 to 5825	53.6 kOhm	1475 to 1625	6.98 kOhm
4775 to 5275	47.5 kOhm	1350 to 1475	6.04 kOhm
4300 to 4775	38.3 kOhm	1250 to 1350	5.49 kOhm
3875 to 4300	29.4 kOhm	1150 to 1250	4.87 kOhm
3500 to 3875	24.3 kOhm	1050 to 1150	4.42 kOhm
3175 to 3500	20.5 kOhm	950 to 1050	3.83 kOhm
2875 to 3175	18.2 kOhm		

**Common Mode**

Analog ground to ac power ground

CMR at dc to 60 Hz	120 dB
CMV at dc to 60 Hz	±1500 Vp per HV test ±354 Vp per IEC spacing

**Accuracy at 25°C**

Maximum Error	
Q2000D	±0.05% R ±1 count
Q9000D	±0.1% R ±10 counts
Reading Tempco	±0.01% R/°C
Zero Tempco	±0.1 count/°C
Warmup to rated accuracy	Less than 1 minute

**18.0 SIGNAL INPUT CONNECTIONS (TB1) (SEE FIGURE 5)**

18.1 The signal input connections for the BSCC ac voltage signal conditioner are made at the standard 3-terminal barrier strip:

<u>Terminal Connection</u>	<u>Signal</u>	<u>Input</u>
4	Analog GND (N/C)	●
5	Signal LO	● —————
6	Signal HI	● —————

18.2 The signal input connections for the BSCC/D ac current signal conditioner are made at the standard 3-terminal barrier strip:

<u>Terminal Connection</u>	<u>Signal</u>	<u>Input</u>
4	Analog GND	●
5	Signal LO	● —————
6	Signal HI	● —————

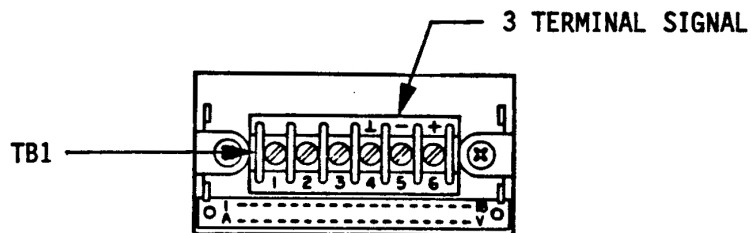

REAR TERMINAL VIEW  
 FIGURE 5. SIGNAL INPUT CONNECTIONS

## 19.0 TESTS AND DIAGNOSTICS

- The signal conditioner board BSCC is designed to function with a main assembly as a minimum configuration. There is no provision for testing a signal conditioner board alone.
- Signal input requirements for your configuration are identified in the specifications for the BSCC signal conditioner.
- Operating power and connections for your configuration are identified in the main assembly section of this manual.
  - NOTE: If using Main Assembly Q2000, refer to Section BQ20/BQ29.
  - If using Main Assembly Q9000, refer to Section BQ90/BQ98.
- Inspect the QUANTA panel meter for physical damage. If damage is apparent, resolve the damage with the shipper or your supplier.

### 19.1 FUNCTIONAL ELECTRICAL TESTING

NOTE: Perform this test after your meter has been configured.

1. Short terminals 5 and 6 on barrier strip (TB1).
2. Apply proper power for your configuration to terminals 1, 2 and 3 on barrier strip (TB1). Display will read approximately zero (0000).



## 20.0 CONFIGURATION PROCEDURE

### 20.1 GENERAL

Use this procedure to determine the configuration of the BSCC or BSCC/D. Configure the meter using the push-on jumpers provided separately or already positioned on the pin forests. Pin forests designations are shown with each configuration chart.

### 20.2 GLOSSARY

The chart below explains various terms which appear throughout the following procedure:

Term	Definition Voltage Input Range	Term	Definition Current Input Range
CVR1	0 / 50 mV ac	DCR1	0 / 20 $\mu$ A ac
CVR2	0 / 200 mV ac	DCR2	0 / 200 $\mu$ A ac
CVR3	0 / 2 V ac	DCR3	0 / 2 mA ac
CVR4	0 / 20 V ac	DCR4	0 / 20 mA ac
CVR5	0 / 200 V ac 0 / 150 V for CE	DCR5	0 / 200 mA ac
CVR6	0 / 750 V ac 0 / 150 for CE	DCR6	0 / 2 A ac
		DCR7	0 / 5 A ac

Term	Definition
V1	Largest input voltage
I1	Largest input current

### 20.3 SELECTION

If the Input is:

Voltage, proceed to Section 20.3.1

Current, proceed to Section 20.3.2

### 20.3.1 Input Voltage Range Selection (CVR1,2,3,4,5,6)

Specify the magnitude of the largest input voltage:

V1 = \_\_\_\_\_ Volts

Select the required range where V1 is equal to or less than the limit of that range.

CVR1 = 50 mV ac                      CR4 = 20 V ac

CVR2 = 200 mV ac                    CR5 = 200 V ac

CVR3 = 2 V ac                        CR6 = 750 V ac

CVR = \_\_\_\_\_

Proceed to Installation (Section 20.4)

### 20.3.2 Input Current Range Selection (DCR1,2,3,4,5,6,7)

Specify the magnitude of the largest input current:

I1 = \_\_\_\_\_ mA

Select the required current range where I1 is equal to or less than the limit of that range.

DCR1 = 20 uA ac                      DCR4 = 20 mA ac

DCR2 = 200 uA ac                    DCR5 = 200 mA ac

DCR3 = 2 mA ac                      DCR6 = 2 A ac

DCR7 = 5 A ac

DCR = \_\_\_\_\_

Based on the current range chosen, select a shunt resistor (R1) from the following:

DCR1 = 10 kOhm, 1%, 1/8W, MF (P/N 8211002)

DCR2 = 1 kOhm, 1%, 1/8W, MF (P/N 8211001)

DCR3 = 100 ohms, 1%, 1/8W, MF (P/N 8211009)

DCR4 = 10 ohms, 1%, 1/8W, MF (P/N 8211008)

DCR5 = 1.0 ohm, 1%, 1/8W, WW (P/N 8710006)

DCR6 = 0.1 ohm, 1%, 1/2W, WW (P/N 8910005)

DCR7 = 0.01 ohm, 1%, 2W, WW (P/N 8910004)

## 20.4 INSTALLATION

### 20.4.1 General

Select the Voltage Range (CVR1-6) or Current Range (DCR1-7) and install the push-on jumper(s) as per the appropriate Subsection of Section 21.0.

### 20.4.2 Reference Voltage (Q9000C or Q9000D only)

Select reference RV1 by installing push-on jumper A as per Subsection 13.3 in Main Assembly Section BQ90/BQ98.

NOTE: Select the RV2 reference if using the DCR7 range. Remove any jumpers in the S3 position as per Subsection 13.3.

### 20.4.3 Current

If a Current Range (DCR1-7) is selected, you must install the shunt resistor (R1) chosen. Install the shunt resistor (R1) as per page 41 (21.2).

### 20.4.4 Decimal Point

If a decimal point is required, refer to the appropriate Main Assembly Section for location and configuration procedure.

NOTE: If using Main Assembly Q2000, refer to Section BQ20/BQ29.  
If using Main Assembly Q9000, refer to Section BQ90/BQ98.

## 21.0 CONFIGURATION CHARTS

### 21.1 INPUT VOLTAGE (CVR1, 2, 3, 4, 5, 6)

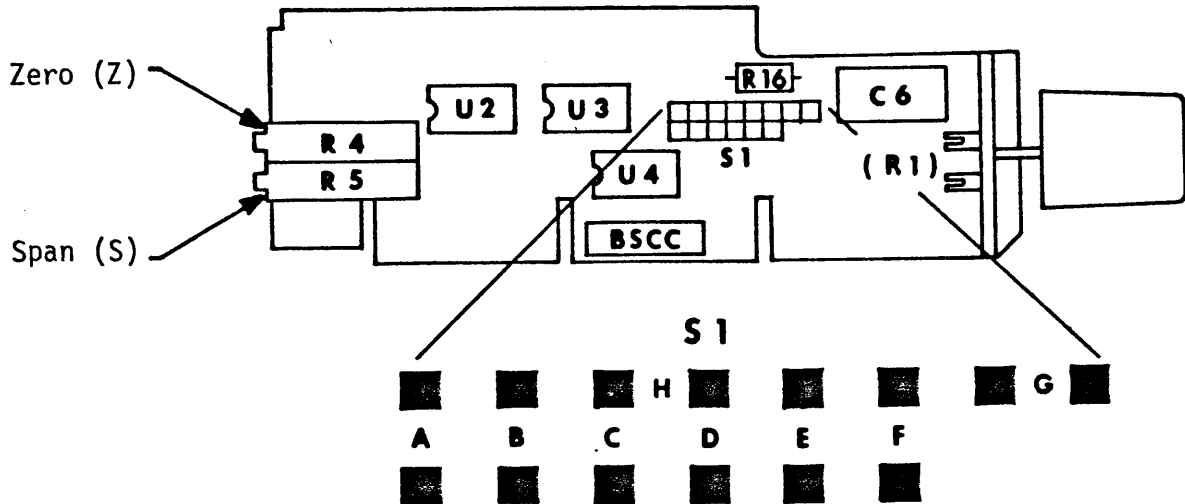

STEP 1: Remove all push-on jumpers not used in the desired configuration(s).

STEP 2: Select the desired configuration from the chart below, then install the push-on jumpers indicated.

Input Voltage Configuration *		S1			
CVR1	50 mV	E	F	G	H
CVR2	200 mV	A	E	F	G
CVR3	2 V	A	D	F	G
CVR4	20 V	A	B	F	G
CVR5	200 V (150 V max for CE)	A	C	F	G
CVR6	750 V (150 V max for CE)	A	C	-	-

\* Used on the Q2000C or Q9000C

## 21.2 INPUT CURRENT (DCR1,2,3,4,5,6,7)

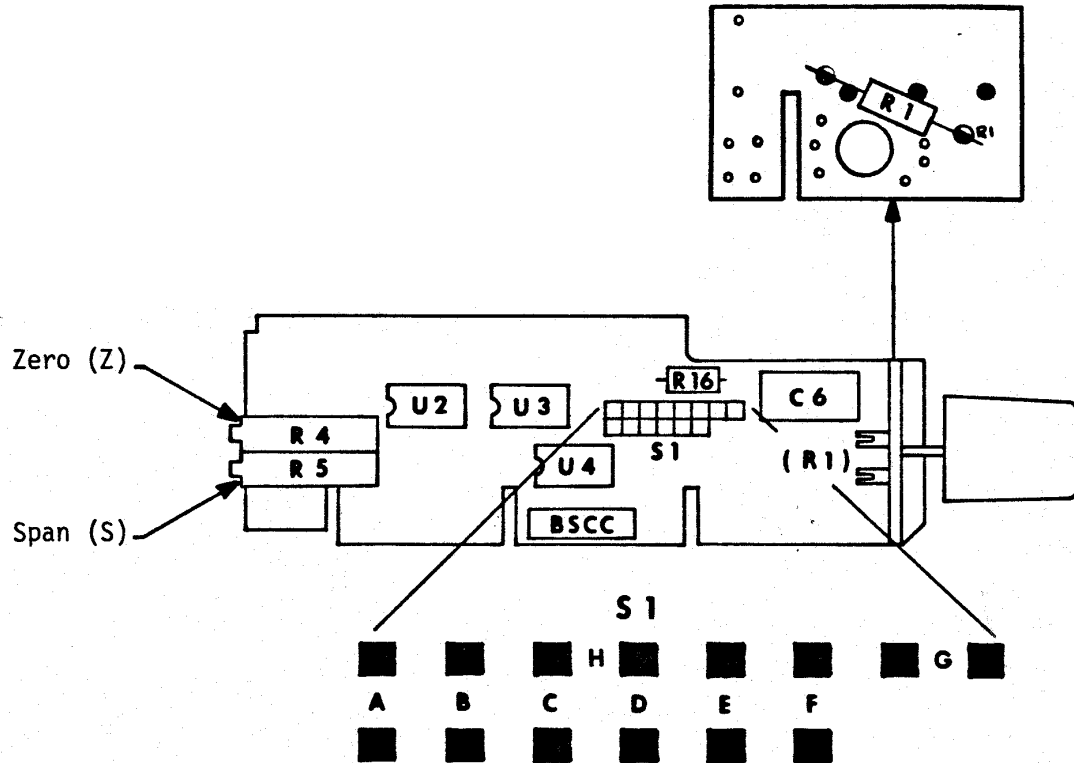

Step 1: Remove all push-on jumpers not used in the desired configuration(s).						
Step 2: Select the desired configuration from the chart below, then install the push-on jumpers indicated.						
Input Current Configuration *		S1				R1
DCR1	20 $\mu$ A Input	A	E	F	G	10 kOhm
DCR2	200 $\mu$ A Input	A	E	F	G	1 kOhm
DCR3	2 mA Input	A	E	F	G	100 ohms
DCR4	20 mA Input	A	E	F	G	10 ohms
DCR5	200 mA Input	A	E	F	G	1.0 ohm
DCR6	2 A Input	A	E	F	G	0.1 ohm
DCR7	5 A Input	E	F	G	H	0.01 ohm

\* Used on the Q2000D or Q9000D

## 22.0 CALIBRATION

### 22.1 Q2000 VOLTAGE RANGES (CVR1-6)

1. Apply an input voltage equal to the low end of the range selected and adjust the zero (Z) pot (R4) to make the display read 000.
2. Apply an input voltage equal to 95% of the high end of the range selected and adjust the span pot (R5) to make the display read 1900 (if CVR6 is selected the display should read 712).
3. Repeat steps above as required to set the display to within  $\pm 1$  count.

### 22.2 Q2000 CURRENT RANGES (DCR1-7)

1. Apply an input current equal to the low end of the range selected and adjust the zero (Z) pot (R4) to make the display read 000.
2. Apply an input current equal to 95% of the high end of the range selected and adjust the span (S) pot (R5) to make the display read 1900.
3. Repeat steps above as required to set the display to within  $\pm 1$  count.

### 22.3 Q9000 VOLTAGE RANGES (CVR1-6)

1. Apply an input voltage equal to the low end of the range selected and adjust the zero (Z) pot (R4) to make the display read 0000.
2. Apply an input voltage equal to 95% of the high end of the range selected and adjust the span pot (R5) to make the display read 9500 (if CVR6 is selected the display should read 712.5).
3. Repeat steps above as required to set the display to within  $\pm 1$  count.

### 22.4 Q9000 CURRENT RANGES (DCR1-7)

1. Apply an input current equal to the low end of the range selected and adjust the zero (Z) pot (R4) to make the display read 0000.
2. Apply an input current equal to 95% of the high end of the range selected and adjust the span (S) pot (R5) to make the display 9500.
3. Repeat steps above as required to set the display to within  $\pm 1$  count.

# 23.0 DRAWINGS

## 23.1 BSCC ASSEMBLY DIAGRAM

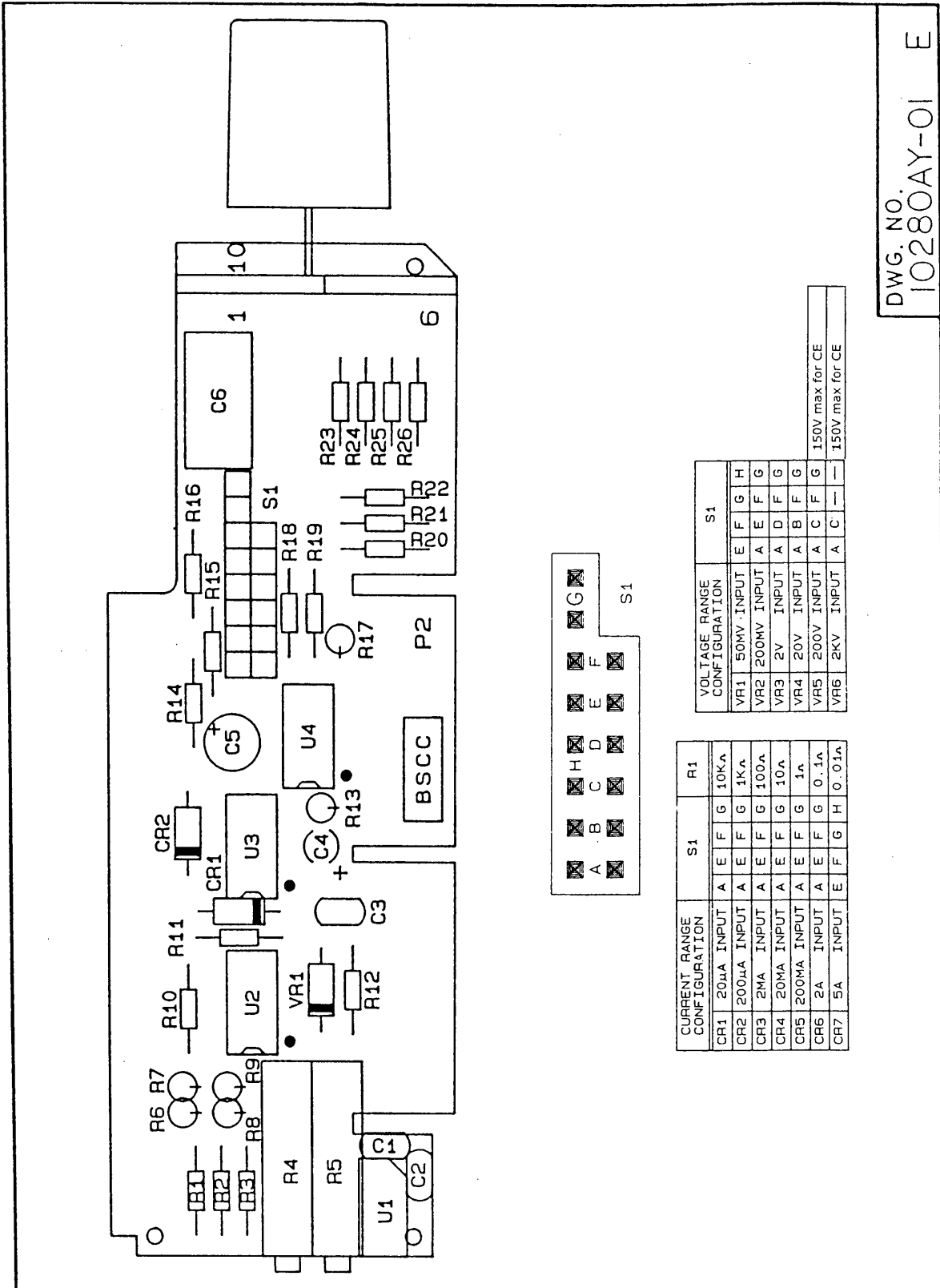

DWG. NO.  
10280AY-01 E

## NOTES



## 24.0 DIGITAL PANEL METER INSTALLATION INSTRUCTIONS

### IMPORTANT:

For proper installation electrical connections must be made according to the model number on the meter label. Write the model number in the following space and use the appropriate instructions for **your** model number.

```
      .--- Power requirement (Section 24.3)
      :
      : .--- Analog output (see Analog Output Manual)
      :
      : .--- Control output (see Controller/
      :                      Interface Manual)
      :
      : .--- Signal input (Section 25.0)
      :
      :
Model number Q2 _____
Model number Q9 _____
```

=====

### 24.1 UNPACKING & INSPECTION

Your QUANTA digital panel meter was systematically inspected and tested, then carefully packed before shipment.

Unpack the instrument and inspect for obvious shipping damage. Notify the freight carrier immediately upon discovery of any shipping damage.

### 24.2 MECHANICAL INSTALLATION

1. Insure that the panel cutout dimensions are as shown on Figure 6.
2. Remove the lower printed circuit board edge connector, (if installed) J1, by pushing two molded plastic tabs away from the connector body and pulling the connector off the printed circuit board. Remove the printed circuit board edge connector, J2, if upper board output option was ordered.
3. Loosen two clamp screws on the rear of the case enough to rotate the two slide clamps.
4. Slide the two slide retainers toward the rear of the case and remove them.
5. From the front of the panel, insert the meter into the panel cutout.
6. Slide the slide retainers back onto the case and push up tightly against the rear of the panel.
7. Rotate the slide clamps back into their original position and tighten enough to hold the case in place. Overtightening can break the clamps.
8. Install the lower printed circuit board edge connector, if supplied, by pushing it on to the prinped circuit board connections. Install the upper printed circuit board edge connector, if used.

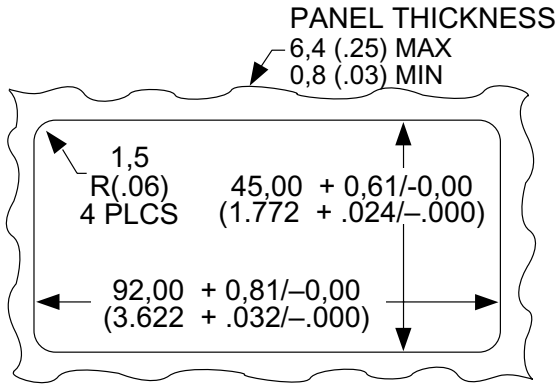

NOTE: Dimensions in Millimeters (Inches)

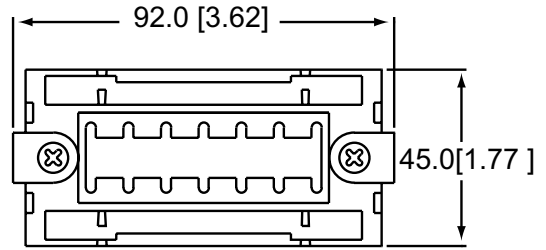

**REAR VIEW**

(TERMINAL BLOCK COVER AND BEZEL NOT SHOWN FOR CLARITY)  
 SLIDE CLAMPS ROTATED AND SLIDE RETAINERS REMOVED AS SHOWN FOR INSTALLATION.

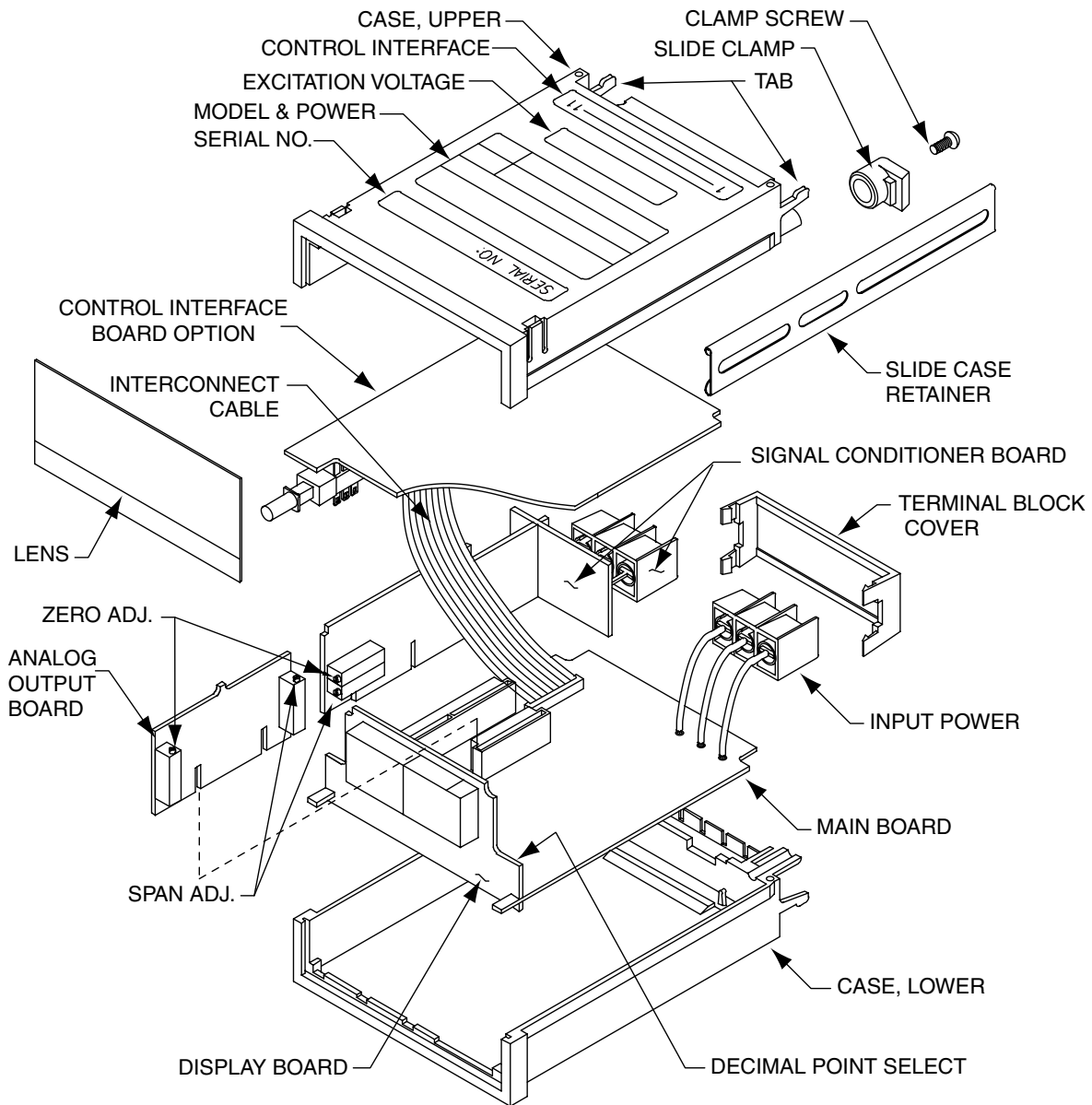

## 24.3 POWER REQUIREMENTS AND CONNECTIONS (TB1)

24.3.1 The standard meter is wired to operate from one of five power sources.

<u>Models</u>	<u>Power Requirements</u>
Q20XXX, Q21XXX and Q90XXX	120 V ac (50-60 Hz)
Q22XXX, Q23XXX and Q92XXX	240 V ac (50-60 Hz)
Q24XXX, Q25XXX and Q94XXX	9-32 V dc
Q26XXX, Q27XXX and Q96XXX	5 V dc
Q28XXX, Q29XXX and Q98XXX	24 V ac (50-60 Hz)

24.3.2 Regardless of the power source used, connections are made to the same terminal barrier strip, TB1, as follows:

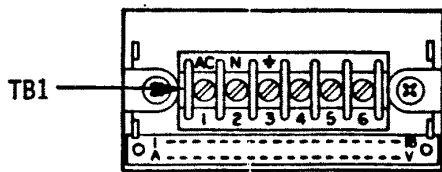

<u>TB1 Terminal Connection</u>	<u>AC Operation</u> 24 V, 120 V, 240 V	<u>Wire Color</u>
1	AC power HI	Black
2	AC power LO (neutral)	White
3	AC power GND	Green

REAR TERMINAL VIEW

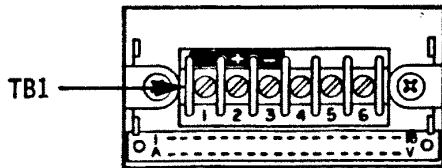

<u>TB1 Terminal Connection</u>	<u>DC Operation</u> 5 V or 9-32 V
1	No Connection
2	DC power +
3	DC power - (return)

## 25.0 SIGNAL INPUT CONNECTIONS (TB1)

The signal input connections for all meters are made at the same terminal barrier strip, TB1, as follows:

### Signal Input Connections For Q2XXXC and Q9XXXC (AC Voltage)

<u>Terminal Connection</u>	<u>Signal</u>	<u>Input</u>
4	Analog GND	●
5	- Signal LO	●
6	+ Signal HI	●

### Signal Input Connections For Q2XXXD and Q9XXXD (AC Current)

<u>Terminal Connection</u>	<u>Signal</u>	<u>Input</u>
4	Analog GND	●
5	- Signal LO	●
6	+ Signal HI	●

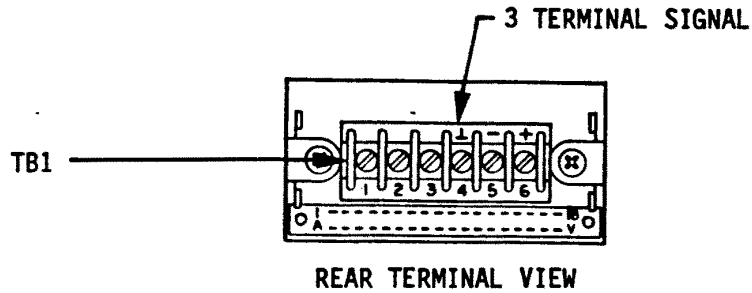





## Warranty/Disclaimer

NEWPORT ELECTRONICS, INC. warrants this unit to be free of defects in materials and workmanship for a period of one (1) year from date of purchase. In addition to NEWPORT's standard warranty period, NEWPORT ELECTRONICS will extend the warranty period for one (1) additional year if the warranty card enclosed with each instrument is returned to NEWPORT.

If the unit should malfunction, it must be returned to the factory for evaluation. NEWPORT's Customer Service Department will issue an Authorized Return (AR) number immediately upon phone or written request. Upon examination by NEWPORT, if the unit is found to be defective it will be repaired or replaced at no charge. NEWPORT's WARRANTY does not apply to defects resulting from any action of the purchaser, including but not limited to mishandling, improper interfacing, operation outside of design limits, improper repair, or unauthorized modification. This WARRANTY is VOID if the unit shows evidence of having been tampered with or shows evidence of being damaged as a result of excessive corrosion; or current, heat, moisture or vibration; improper specification; misapplication; misuse or other operating conditions outside of NEWPORT's control. Components which wear are not warranted, including but not limited to contact points, fuses, and triacs.

**NEWPORT is pleased to offer suggestions on the use of its various products. However, NEWPORT neither assumes responsibility for any omissions or errors nor assumes liability for any damages that result from the use of its products in accordance with information provided by NEWPORT, either verbal or written. NEWPORT warrants only that the parts manufactured by it will be as specified and free of defects. NEWPORT MAKES NO OTHER WARRANTIES OR REPRESENTATIONS OF ANY KIND WHATSOEVER, EXPRESSED OR IMPLIED, EXCEPT THAT OF TITLE, AND ALL IMPLIED WARRANTIES INCLUDING ANY WARRANTY OF MERCHANTABILITY AND FITNESS FOR A PARTICULAR PURPOSE ARE HEREBY DISCLAIMED. LIMITATION OF LIABILITY: The remedies of purchaser set forth herein are exclusive and the total liability of NEWPORT with respect to this order, whether based on contract, warranty, negligence, indemnification, strict liability or otherwise, shall not exceed the purchase price of the component upon which liability is based. In no event shall NEWPORT be liable for consequential, incidental or special damages.**

CONDITIONS: Equipment sold by NEWPORT is not intended to be used, nor shall it be used: (1) as a "Basic Component" under 10 CFR 21 (NRC), used in or with any nuclear installation or activity; or (2) in medical applications or used on humans. Should any Product(s) be used in or with any nuclear installation or activity, medical application, used on humans, or misused in any way, NEWPORT assumes no responsibility as set forth in our basic WARRANTY/DISCLAIMER language, and additionally, purchaser will indemnify NEWPORT and hold NEWPORT harmless from any liability or damage whatsoever arising out of the use of the Product(s) in such a manner.

## Return Requests/Inquiries

Direct all warranty and repair requests/inquiries to the NEWPORT Customer Service Department. BEFORE RETURNING ANY PRODUCT(S) TO NEWPORT, PURCHASER MUST OBTAIN AN AUTHORIZED RETURN (AR) NUMBER FROM NEWPORT'S CUSTOMER SERVICE DEPARTMENT (IN ORDER TO AVOID PROCESSING DELAYS). The assigned AR number should then be marked on the outside of the return package and on any correspondence.

The purchaser is responsible for shipping charges, freight, insurance and proper packaging to prevent breakage in transit.

FOR **WARRANTY** RETURNS, please have the following information available BEFORE contacting NEWPORT:

1. P.O. number under which the product was PURCHASED,
2. Model and serial number of the product under warranty, and
3. Repair instructions and/or specific problems relative to the product.

FOR **NON-WARRANTY** REPAIRS, consult NEWPORT for current repair charges. Have the following information available BEFORE contacting NEWPORT:

1. P.O. number to cover the COST of the repair,
2. Model and serial number of product, and
3. Repair instructions and/or specific problems relative to the product.

NEWPORT's policy is to make running changes, not model changes, whenever an improvement is possible. This affords our customers the latest in technology and engineering.

NEWPORT is a registered trademark of NEWPORT ELECTRONICS, INC.

© Copyright 2006 NEWPORT ELECTRONICS, INC. All rights reserved. This document may not be copied, photocopied, reproduced, translated, or reduced to any electronic medium or machine-readable form, in whole or in part, without prior written consent of NEWPORT ELECTRONICS, INC.

For immediate technical or application assistance please call:

**1-800-6397678®**  
**1-800-NEWPORT**

---

Newport Electronics, Inc.  
2229 South Yale Street • Santa Ana, CA • 92704 • U.S.A.  
TEL: (714) 540-4914 • FAX: (203) 968-7311  
Toll Free: 1-800-639-7678 • www.newportUS.com • e-mail:info@newportUS.com  
ISO 9001 Certified

---

Newport Technologies, Inc.  
976 Bergar • Laval (Quebec) • H7L 5A1 • Canada  
TEL: (514) 335-3183 • FAX: (514) 856-6886  
Toll Free: 1-800-639-7678 • www.newport.ca • e-mail:info@newport.ca

---

Newport Electronics, Ltd.  
One Omega Drive • River Bend Technology Centre  
Northbank, Irlam • Manchester M44 5BD • United Kingdom  
Tel: +44 161 777 6611 • FAX: +44 161 777 6622  
Toll Free: 0800 488 488 • www.newportuk.co.uk • e-mail:sales@newportuk.co.uk

---

Newport Electronics spol s.r.o.  
Frystatska 184, 733 01 Karviná • Czech Republic  
TEL: +420 59 6311899 • FAX: +420 59 6311114  
Toll Free: 0800-1-66342 • www.newport.cz • e-mail: info@newport.cz

---

Newport Electronics GmbH  
Daimlerstrasse 26 • D-75392 Deckenpfronn • Germany  
TEL: 49 7056 9398-0 • FAX: 49 7056 9398-29  
Toll Free: 0800 / 6397678 • www.newport.de • e-mail: sales@newport.de

---

Mexico and Latin America  
FAX: 001 (203) 359-7807  
En Español: 001 (203) 359-7803

---

<b>NEWPORTnet<sup>SM</sup> On-Line Service</b> www.newportUS.com
---

<b>Internet e-mail</b> info@newportUS.com
--

 **NEWPORT** Electronics, Inc.