

All rights reserved. Reproduction or Issue to third parties is not permitted without written permission from

1.64 Max

2.2

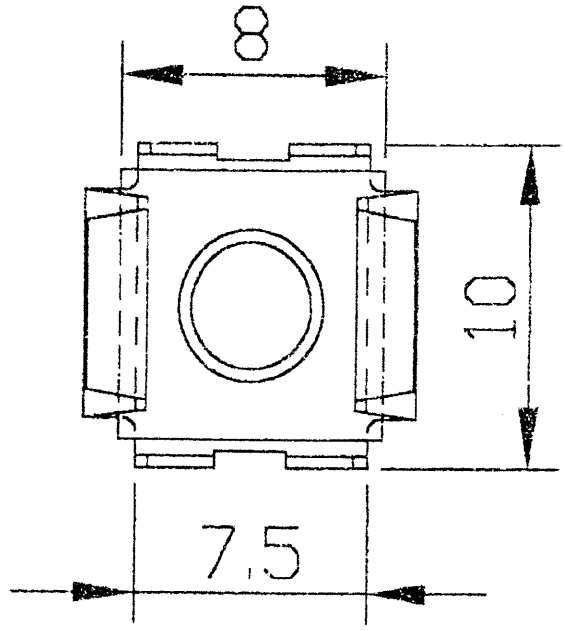
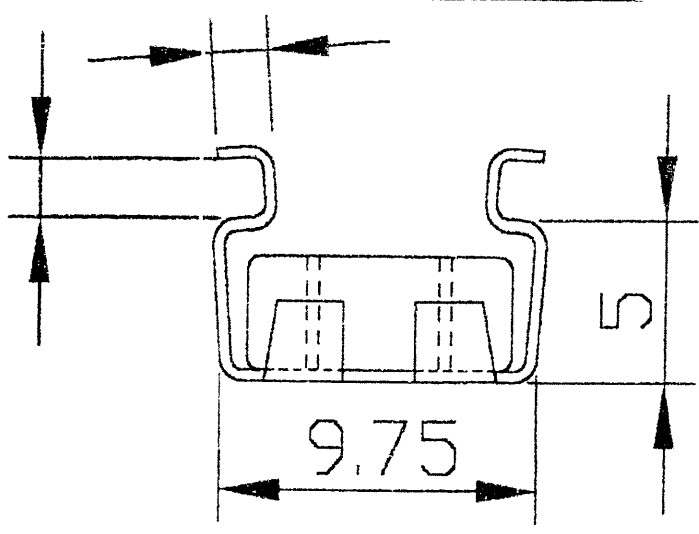

M4 NARROW

| | | | | | | |
|--|--------------------|-----------------------------------|---|-------------------|---------------|--------------|
| Tolerances: General +/- 0.4mm | | | Material: Cage: 0.46mm CS 70 / Nut: Mild Steel | | | |
| Heat Treatment: Cage: H&T 380/420 VPN | | | Finish: Cage & Nut: Zinc & Yellow Pass to ZN3 | | | |
| Drawn By: I R | Checked By: L W | Approved By/Date: S F 10/12/99 | File Name: Cage Nut | Date: 10/12/99 | Scale: NTS | |
| | | | Title: M4 Cage Nut | | | Issue: 1 |
| | | | Part No: CN/4M/ND/ZP | | | Page: 1/1 |