

Suitable for lighting and motor load, 1 Form A 50A latching relays

DJ-H RELAYS (ADJH)

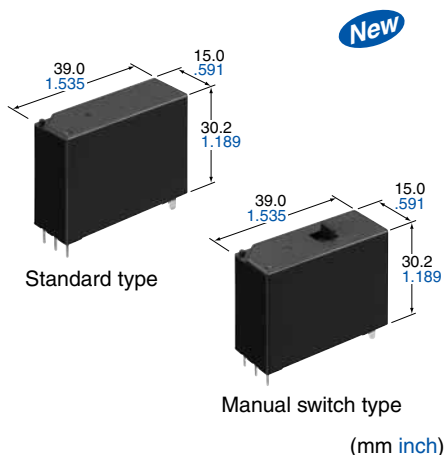

RoHS compliant

Protective construction: Flux-resistant type

FEATURES

- High inrush capability
 - Tungsten load (TV-20 class)
 - Electronic ballast load (NEMA410)
 - Capacitive load (IEC60669-1)
- Supports manual operation
 - Manual switch type available

TYPICAL APPLICATIONS

- Smart house (Shutter and blind control)
- Lighting control

ORDERING INFORMATION

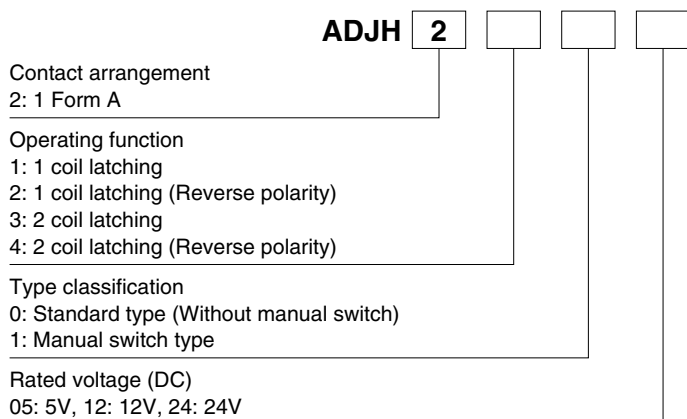

TYPES

1. Standard type (Without manual switch)

Contact arrangement	Rated voltage	Type No.		Standard packing	
		1 coil latching type	2 coil latching type	Carton	Case
1 Form A	5V DC	ADJH21005	ADJH23005	50 pcs.	200 pcs.
	12V DC	ADJH21012	ADJH23012		
	24V DC	ADJH21024	ADJH23024		

*Reverse polarity type available. (1 coil latching type: ADJH220**, 2 coil latching type: ADJH240**)

2. Manual switch type

Contact arrangement	Rated voltage	Type No.		Standard packing	
		1 coil latching type	2 coil latching type	Carton	Case
1 Form A	5V DC	ADJH21105	ADJH23105	50 pcs.	200 pcs.
	12V DC	ADJH21112	ADJH23112		
	24V DC	ADJH21124	ADJH23124		

*Reverse polarity type available. (1 coil latching type: ADJH221**, 2 coil latching type: ADJH241**)

RATING

1. Coil data

1) 1 coil latching type

Rated voltage	Set voltage (at 20°C 68°F)*1	Reset voltage (at 20°C 68°F)*1	Rated operating current [±10%] (at 20°C 68°F)		Coil resistance [±10%] (at 20°C 68°F)		Rated operating power	Max. allowable voltage (at 20°C 68°F)
			Set coil	Reset coil	Set coil	Reset coil		
5V DC	Max. 75% or less of rated voltage (Initial)	Max. 75% or less of rated voltage (Initial)	200mA	200mA	25Ω	25Ω	1,000mW	130% of rated voltage
12V DC			83.3mA	83.3mA	144Ω	144Ω		
24V DC			41.7mA	41.7mA	576Ω	576Ω		

*1. Square, pulse drive

2) 2 coil latching type

Rated voltage	Set voltage (at 20°C 68°F)*1	Reset voltage (at 20°C 68°F)*1	Rated operating current [±10%] (at 20°C 68°F)		Coil resistance [±10%] (at 20°C 68°F)		Rated operating power	Max. allowable voltage (at 20°C 68°F)
			Set coil	Reset coil	Set coil	Reset coil		
5V DC	Max. 75% or less of rated voltage (Initial)	Max. 75% or less of rated voltage (Initial)	400mA	400mA	12.5Ω	12.5Ω	2,000mW	130% of rated voltage
12V DC			166.7mA	166.7mA	72Ω	72Ω		
24V DC			83.3mA	83.3mA	288Ω	288Ω		

*1. Square, pulse drive

2. Specifications

Characteristics	Item	Specifications	
Contact rating	Arrangement	1 Form A	
	Contact resistance (Initial)	Max. 20 mΩ (by voltage drop 24 V DC 1A)	
	Contact material	AgSnO ₂ type	
	Contact rating (Resistive load)	50A 277V AC	
	Max. switching power (Resistive load)	13,850 VA (50A 277V AC)	
	Max. switching voltage	480V AC	
	Max. switching current	50A (AC)	
	Min. switching load (Reference value)*1	100mA 5 V DC	
Insulation resistance (Initial)		Min. 1,000MΩ at 500V DC Measured portion is the same as the case of dielectric voltage	
Dielectric strength (Initial)	Between open contacts	1,500 Vrms for 1min. (Detection current: 10mA)	
	Between contact and coil	4,000 Vrms for 1min. (Detection current: 10mA)	
Surge withstand voltage*2 (Initial)	Between contact and coil	12,000 V	
Time characteristics	Set time	Max. 20ms (Initial) (at 20°C 68°F) at rated voltage, without bounce	
	Reset time	Max. 20ms (Initial) (at 20°C 68°F) at rated voltage, without bounce	
Mechanical characteristics	Shock resistance	Functional	100 m/s ² (half-sine shock pulse: 11 ms, detection time: 10μs)
		Destructive	1,000 m/s ² (half-sine shock pulse: 6 ms)
	Vibration resistance	Functional	10 to 55 Hz at double amplitude of 1.5 mm (detection time: 10μs)
		Destructive	10 to 55 Hz at double amplitude of 2.0 mm
Mechanical life		Min. 1×10 ⁶ (at 180 times/min.)	
Conditions	Conditions for operation, transport and storage*3	Ambient Temperature: -40 to +85°C -40 to +185°F Humidity: 5 to 85% R.H. (Not freezing and condensing at low temperature)	
Unit weight		Approx. 31 g 1.09 oz	

Notes: *1. Minimum switching load is a guide to the lower current limit of switching under the micro-load. This parameter is changed by the condition, such as switching times, environment condition, and expected reliability. When the relay is used lower than minimum switching load, reliability is attrition. Please use the relay over minimum switching load.

*2. Wave is standard shock voltage of ±1.2×50μs according to JEC-212-1981

*3. Allowable range when in original packaging is -40 to +70°C -40 to +158°F.

3. Expected electrical life

Type	Load	Switching capacity	No. of operations	
1 Form A	Resistive load	50A 277V AC	Min. 1 × 10 ⁴ (ON:OFF = 1s:9s)	
		25A 277V AC	Min. 1 × 10 ⁵ (ON:OFF = 1s:9s)	
	Inrush load	Tungsten load	2,400W 120V AC	Min. 2.5 × 10 ⁴ (ON:OFF = 1s:59s)
		Electronic ballast load	20A 277V AC	Min. 6 × 10 ³ (ON:OFF = 1s:9s)
		Capacitive load (IEC 60669-1)	20A 250V AC 200μF	Min. 3 × 10 ⁴ (ON:OFF = 1s:9s)

4. Inrush load (Electrical life diagram)

Load	Tungsten load	Electronic ballast load	Capacitive load (IEC 60669-1)
Switching capacity	2,400W 120V AC	20A 277V AC	20A 250V AC 200 μ F
Load voltage	120V AC (60Hz)	277V AC (60Hz)	250V AC (60Hz)
Load current	Inrush 250A _{O-P} Steady-state 20Arms	Inrush 480A _{O-P} Steady-state 16Arms	Inrush 400A _{O-P} Steady-state 20Arms
Circuit			
Current waveform			

DJ-H (ADJH2)

DIMENSIONS (mm inch)

The CAD data of the products with a **CAD Data** mark can be downloaded from: <http://industrial.panasonic.com/ac/e/>

1. Standard type (Without manual switch)

CAD Data

External dimensions

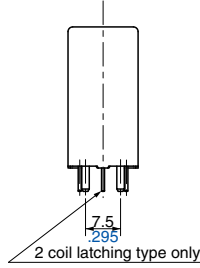
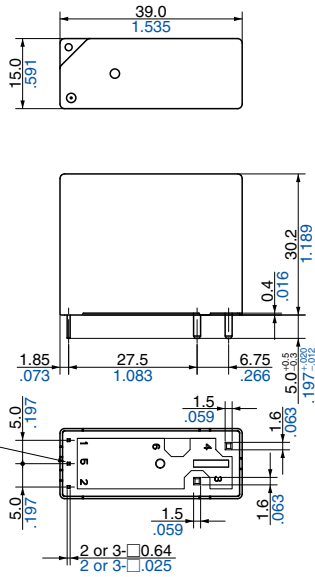

PC board pattern (Bottom view)

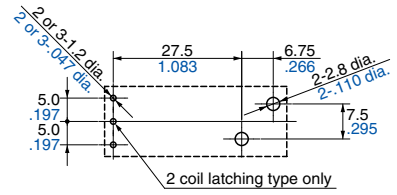

Tolerance: $\pm 0.1 \pm 0.004$

Schematic (Bottom view)

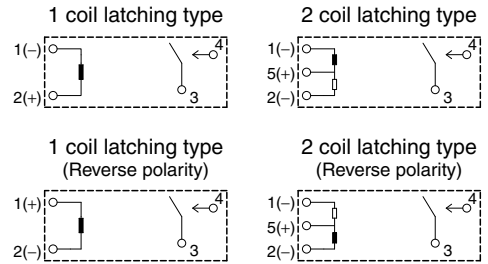

General tolerance: $\pm 0.3 \pm 0.012$

2. Manual switch type

CAD Data

External dimensions

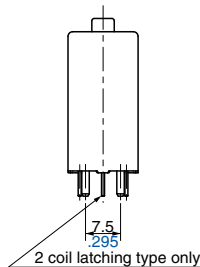
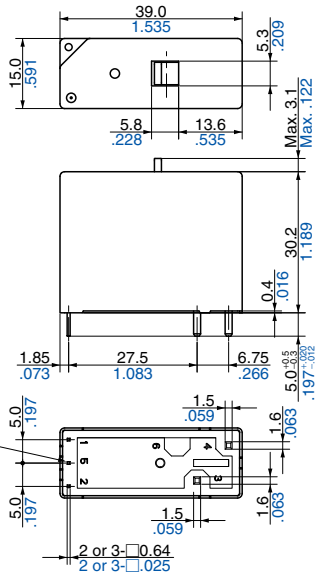

PC board pattern (Bottom view)

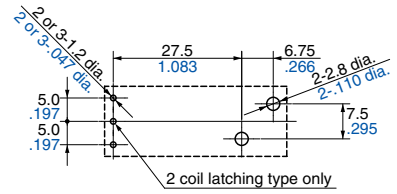

Tolerance: $\pm 0.1 \pm 0.004$

Schematic (Bottom view)

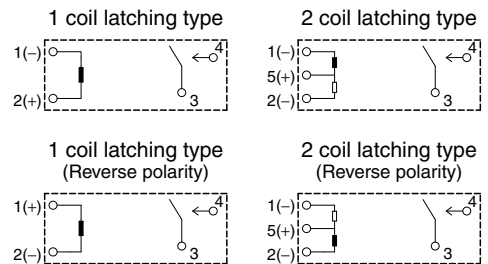

General tolerance: $\pm 0.3 \pm 0.012$

NOTES

1. For cautions for use, please read “GENERAL APPLICATION GUIDELINES”.
2. Regarding the set/reset pulse time of the latching type relay, it is recommended to apply rated voltage for minimum 100ms pulse across the coil to secure the sure operation considering the ambient temperature and condition change through service life.

Please contact

Panasonic Corporation

Electromechanical Control Business Division

■ 1006, Oaza Kadoma, Kadoma-shi, Osaka 571-8506, Japan
industrial.panasonic.com/ac/e/

Panasonic®

©Panasonic Corporation 2016