

User Guide

Keysight 34921A-34925A Low Frequency Multiplexer Modules

Notices

© Keysight Technologies, Inc. 2016

No part of this manual may be reproduced in any form or by any means (including electronic storage and retrieval or translation into a foreign language) without prior agreement and written consent from Keysight Technologies, Inc. as governed by United States and international copyright laws.

Manual Part Number

34980-90021

Edition

Second Edition, January 2016

Printed in

Malaysia

Published by

Keysight Technologies, Inc.
900 S. Taft Ave.
Loveland, CO 80537 USA

Trademarks

PICMG[®], Compact PCI[®] are registered trademarks of the PCI Industrial Computer Manufacturers Group.

AdvancedTCA[®] and ATCA are registered trademarks of the PCI Industrial Computer Manufacturers Group.

PCI-SIG[®], PCI Express[®], and PCIe[®] are registered trademarks of PCI-SIG.

Technology Licenses

The hardware and/or software described in this document are furnished under a license and may be used or copied only in accordance with the terms of such license.

Declaration of Conformity

Declarations of Conformity for this product and for other Keysight products may be downloaded from the Web. Go to <http://keysight.com/go/conformity>.

You can then search by product number to find the latest Declaration of Conformity.

U.S. Government Rights

The Software is “commercial computer software,” as defined by Federal Acquisition Regulation (“FAR”) 2.101. Pursuant to FAR 12.212 and 27.405-3 and Department of Defense FAR Supplement (“DFARS”) 227.7202, the U.S. government acquires commercial computer software under the same terms by which the software is customarily provided to the public. Accordingly, Keysight provides the Software to U.S. government customers under its standard commercial license, which is embodied in its End User License Agreement (EULA), a copy of which can be found at <http://www.keysight.com/find/sweula>. The license set forth in the EULA represents the exclusive authority by which the U.S. government may use, modify, distribute, or disclose the Software. The EULA and the license set forth therein, does not require or permit, among other things, that Keysight: (1) Furnish technical information related to commercial computer software or commercial computer software documentation that is not customarily provided to the public; or (2) Relinquish to, or otherwise provide, the government rights in excess of these rights customarily provided to the public to use, modify, reproduce, release, perform, display, or disclose commercial computer software or commercial computer software documentation. No additional government requirements beyond those set forth in the EULA shall apply, except to the extent that those terms, rights, or licenses are explicitly required from all providers of commercial computer software pursuant to the FAR and the DFARS and are set forth specifically in writing elsewhere in the EULA. Keysight shall be under no obligation to update, revise or otherwise modify the Software. With respect to any technical data as defined by FAR 2.101, pursuant to FAR 12.211 and 27.404.2 and DFARS 227.7102, the U.S. government acquires no greater than Limited Rights as defined in FAR 27.401 or DFAR 227.7103-5 (c), as applicable in any technical data.

Warranty

THE MATERIAL CONTAINED IN THIS DOCUMENT IS PROVIDED “AS IS,” AND IS SUBJECT TO BEING CHANGED, WITHOUT NOTICE, IN FUTURE EDITIONS. FURTHER, TO THE MAXIMUM EXTENT PERMITTED BY APPLICABLE LAW, KEYSIGHT DISCLAIMS ALL WARRANTIES, EITHER EXPRESS OR IMPLIED, WITH REGARD TO THIS MANUAL AND ANY INFORMATION CONTAINED HEREIN, INCLUDING BUT NOT LIMITED TO THE IMPLIED WARRANTIES OF MERCHANTABILITY AND FITNESS FOR A PARTICULAR PURPOSE. KEYSIGHT SHALL NOT BE LIABLE FOR ERRORS OR FOR INCIDENTAL OR CONSEQUENTIAL DAMAGES IN CONNECTION WITH THE FURNISHING, USE, OR PERFORMANCE OF THIS DOCUMENT OR OF ANY INFORMATION CONTAINED HEREIN. SHOULD KEYSIGHT AND THE USER HAVE A SEPARATE WRITTEN AGREEMENT WITH WARRANTY TERMS COVERING THE MATERIAL IN THIS DOCUMENT THAT CONFLICT WITH THESE TERMS, THE WARRANTY TERMS IN THE SEPARATE AGREEMENT SHALL CONTROL.

Keysight Technologies does not warrant third-party system-level (combination of chassis, controllers, modules, etc.) performance, safety, or regulatory compliance unless specifically stated.

Safety Information

CAUTION

A CAUTION denotes a hazard. It calls attention to an operating procedure or practice that, if not correctly performed or adhered to, could result in damage to the product or loss of important data. Do not proceed beyond a CAUTION notice until the indicated conditions are fully understood and met.

WARNING

A WARNING denotes a hazard. It calls attention to an operating procedure or practice, that, if not correctly performed or adhered to, could result in personal injury or death. Do not proceed beyond a WARNING notice until the indicated conditions are fully understood and met.

Safety Information

The following general safety precautions must be observed during all phases of operation of this instrument. Failure to comply with these precautions or with specific warnings or operating instructions in the product manuals violates safety standards of design, manufacture, and intended use of the instrument. Keysight Technologies assumes no liability for the customer's failure to comply with these requirements.

General

Do not use this product in any manner not specified by the manufacturer. The protective features of this product must not be impaired if it is used in a manner specified in the operation instructions.

Before Applying Power

Verify that all safety precautions are taken. Make all connections to the unit before applying power. Note the external markings described under "Safety Symbols".

Ground the Instrument

Keysight chassis' are provided with a grounding-type power plug. The instrument chassis and cover must be connected to an electrical ground to minimize shock hazard. The ground pin must be firmly connected to an electrical ground (safety ground) terminal at the power outlet. Any interruption of the protective (grounding) conductor or disconnection of the protective earth terminal will cause a potential shock hazard that could result in personal injury.

Do Not Operate in an Explosive Atmosphere

Do not operate the module/chassis in the presence of flammable gases or fumes.

Do Not Operate Near Flammable Liquids

Do not operate the module/chassis in the presence of flammable liquids or near containers of such liquids.

Cleaning

Clean the outside of the Keysight module/chassis with a soft, lint-free, slightly dampened cloth. Do not use detergent or chemical solvents.

Do Not Remove Instrument Cover

Only qualified, service-trained personnel who are aware of the hazards involved should remove instrument covers. Always disconnect the power cable and any external circuits before removing the instrument cover.

Keep away from live circuits

Operating personnel must not remove equipment covers or shields. Procedures involving the removal of covers and shields are for use by service-trained personnel only. Under certain conditions, dangerous voltages may exist even with the equipment switched off. To avoid dangerous electrical shock, DO NOT perform procedures involving cover or shield removal unless you are qualified to do so.

DO NOT operate damaged equipment

Whenever it is possible that the safety protection features built into this product have been impaired, either through physical damage, excessive moisture, or any other reason, REMOVE POWER and do not use the product until safe operation can be verified by service-trained personnel. If necessary, return the product to an Keysight Technologies Sales and Service Office for service and repair to ensure the safety features are maintained.

DO NOT block the primary disconnect

The primary disconnect device is the appliance connector/power cord when a chassis used by itself, but when installed into a rack or system the disconnect may be impaired and must be considered part of the installation.

Do Not Modify the Instrument

Do not install substitute parts or perform any unauthorized modification to the product. Return the product to an Keysight Sales and Service Office to ensure that safety features are maintained.

In Case of Damage

Instruments that appear damaged or defective should be made inoperative and secured against unintended operation until they can be repaired by qualified service personnel

CAUTION

Do NOT block vents and fan exhaust: To ensure adequate cooling and ventilation, leave a gap of at least 50mm (2") around vent holes on both sides of the chassis.

Do NOT operate with empty slots: To ensure proper cooling and avoid damaging equipment, fill each empty slot with an AXle filler panel module.

Do NOT stack free-standing chassis: Stacked chassis should be rack-mounted.

All modules are grounded through the chassis: During installation, tighten each module's retaining screws to secure the module to the chassis and to make the ground connection.

WARNING

Operator is responsible to maintain safe operating conditions. To ensure safe operating conditions, modules should not be operated beyond the full temperature range specified in the Environmental and physical specification. Exceeding safe operating conditions can result in shorter lifespan, improper module performance and user safety issues. When the modules are in use and operation within the specified full temperature range is not maintained, module surface temperatures may exceed safe handling conditions which can cause discomfort or burns if touched. In the event of a module exceeding the full temperature range, always allow the module to cool before touching or removing modules from the chassis.

Safety Symbols







CAUTION

A CAUTION denotes a hazard. It calls attention to an operating procedure or practice, that, if not correctly performed or adhered to could result in damage to the product or loss of important data. Do not proceed beyond a CAUTION notice until the indicated conditions are fully understood and met.

WARNING

A WARNING denotes a hazard. It calls attention to an operating procedure or practice, that, if not correctly performed or adhered to, could result in personal injury or death. Do not proceed beyond a WARNING notice until the indicated conditions are fully understood and met.

Products display the following symbols:

-  Warning, risk of electric shock
-  Refer to manual for additional safety information.
-  Earth Ground.
-  Chassis Ground.
-  Alternating Current (AC).
-  Standby Power. Unit is not completely disconnected from AC mains when switch is in standby.
-  Antistatic precautions should be taken.
- CAT I IEC Measurement Category I, II, III, or IV
- CAT II
- CAT III
- CAT IV

For localized Safety Warnings, Refer to Keysight Safety document (p/n 9320-6792).



The CSA mark is a registered trademark of the Canadian Standards Association and indicates compliance to the standards laid out by them. Refer to the product Declaration of Conformity for details.



Notice for European Community: This product complies with the relevant European legal Directives: EMC Directive (2004/108/EC) and Low Voltage Directive (2006/95/EC).



The Regulatory Compliance Mark (RCM) mark is a registered trademark. This signifies compliance with the Australia EMC Framework regulations under the terms of the Radio Communication Act of 1992.

ICES/NMB-001

ICES/NMB-001 indicates that this ISM device complies with the Canadian ICES-001.



This symbol represents the time period during which no hazardous or toxic substance elements are expected to leak or deteriorate during normal use. Forty years is the expected useful life of this product.



South Korean Class A EMC Declaration. This equipment is Class A suitable for professional use and is for use in electromagnetic environments outside of the home.

A 급 기기 (업무용 방송통신기자재) 이 기기는 업무용 (A 급) 전자파적합기기로서 판매자 또는 사용자는 이 점을 주의하시기 바라 며 , 가정외의 지역에서 사용하는 것을 목적으로 합니다.



Waste Electrical and Electronic Equipment (WEEE) Directive 2002/96/EC

This product complies with the WEEE Directive (2002/96/EC) marking requirement. The affixed product label (see below) indicates that you must not discard this electrical/electronic product in domestic household waste.

Product Category: With reference to the equipment types in the WEEE directive Annex 1, this product is classified as a "Monitoring and Control instrumentation" product.

Do not dispose in domestic household waste.

To return unwanted products, contact your local Keysight office for more information.



Contents

1 Low Frequency Multiplexer Modules

Multiplexer Module Capabilities	9
Measurement Functions for the Multiplexer Modules	10
Operating Considerations	11
SCPI Programming Examples for the Multiplexer Modules	12
34921A 40-Channel Armature Multiplexer with Low Thermal Offset	15
34921A Simplified Schematic	17
34921A D-Sub Connectors	18
34921T Terminal Block	20
34922A 70-Channel Armature Multiplexer	22
34922A Simplified Schematic	23
34922A D-Sub Connectors	24
34922T Terminal Blocks	26
34923A 40/80-Channel Reed Multiplexer	28
Two-Wire Mode	29
Four-Wire Mode	29
One-Wire Mode	29
34923A Simplified Schematic for Two- or Four-Wire Mode	31
34923A D-Sub Connectors for Two- or Four-Wire Mode	32
34923T-001 Terminal Block for Two-Wire or Four-Wire Mode	34
34923A Simplified Schematic for One-Wire Mode	35
34923A D-Sub Connectors for One-Wire Mode	36
34923T-002 Terminal Block for One-Wire Mode	38
34924A 70-Channel Reed Multiplexer	40
34924A Simplified Schematic	42
34924A D-Sub Connectors	43
34924T Terminal Blocks	45
34925A 40/80-Channel Optically-Isolated FET Multiplexer	47
Two-Wire Mode	47
Four-Wire Mode	48
One-Wire Mode	48
Interlock Protection	48
Overvoltage Protection	48
34925A Simplified Schematic for Two- or Four-Wire Mode	50
34925A D-Sub Connectors for Two- or Four-Wire Mode	51
34925T-001 Terminal Block for Two-Wire or Four-Wire Mode	53

34925A Simplified Schematic for One-Wire Mode	54
34925A D-Sub Connectors for One-Wired Mode	55
34925T-002 Terminal Block for One-Wire Mode	57

Index

Low Frequency Multiplexer Modules

This User's Guide covers the following five plug-in modules for the Keysight 34980A Multifunction Switch/Measure Unit:

34921A	40-channel armature multiplexer w/low thermal offset
34922A	70-channel armature multiplexer
34923A	40/80-channel reed multiplexer
34924A	70-channel reed multiplexer
34925A	40-channel optically isolated FET multiplexer

Multiplexer Module Capabilities

Each multiplexer (MUX) module features two banks of channels, providing broad multiplexing and measurement capabilities. Briefly:

- You can connect a MUX to an external instrument, and/or switch multiple analog signals to the internal DMM.
- With the 34921A, 34922A, 34923A, and the 34924A modules, you can close more than one channel in each bank simultaneously ($N:1$ configuration).
- Since the 34925A module is protected with overvoltage circuitry, you can close only one channel in each bank at one time ($1:N$ configuration).
- You can connect multiple MUXes to the built-in Analog Buses, which allow you to scan as many as 560 2-wire (differential) channels or 640 1-wire (single-ended) channels in one 34980A mainframe.

Measurement Functions for the Multiplexer Modules

The MUX modules support the DMM measurement functions shown in the following table.

Measurement Function(s)	34922A 40-ch Armature Mux	34922A 70-ch Armature Mux	34923A 40-ch Reed Mu x (2-Wire)	34923A 80-ch Reed Mux (1-Wire)	34924A 70-ch Reed Mu x)	34925 A 40-ch FET Mux (2-Wire)	34925A 80-ch FET Mux (1-Wire)
Voltage, AC/DC	Yes	Yes	Yes	Yes	Yes	Yes	Yes
Current, AC/DC	Yes ¹	No	No	No	No	No	No
Frequency/Period	Yes	Yes	Yes	Yes	Yes	Yes	Yes
Ohms 2-Wire	Yes	Yes	Yes ⁵	Yes ⁵	Yes ⁵	Yes ⁶	Yes ⁶
Ohms 4-Wire	Yes	Yes	Yes ⁵	No	Yes ⁵	Yes ⁶	No
Thermocouple	Yes ²	Yes ³	Yes ^{3,4}	Yes ^{3,4}	Yes ^{3,4}	Yes ³	Yes ³
RTD 2-Wire	Yes	Yes	Yes ⁵	Yes ⁵	Yes ⁵	No	No
RTD 4-Wire	Yes	Yes	Yes ⁵	No	Yes ⁵	Yes ⁶	No
Thermistor	Yes	Yes	Yes ⁵	Yes ⁵	Yes ⁵	No	No

¹ Direct current measurements are allowed on channels 41 through 44 only (for all other channels, external shunts are required).

² Optional 34921T Terminal Block is required for thermocouple measurements with built-in internal reference junction.

³ A fixed or external reference junction temperature is required for thermocouple measurement with this module.

⁴ Impact of higher offset voltage specification ($< 50 \mu\text{V}$) must be taken into consideration.

⁵ 1 k Ω or higher range used unless 100 Ω series resistors are bypassed on module.

⁶ 10 k Ω or higher range used for loads over approximately 300 Ω due to series resistance of FET channels.

Operating Considerations

Current Ratings

See the *Introduction to the Plug In Modules* chapter of the 34980A Mainframe User's Guide for detailed environmental operating conditions for the 34980A mainframe and its installed modules. That guidance sets maximum per channel current ratings at rated voltage for pollution degree 1 (dry) and pollution degree 2 (possible condensation) conditions, for all of the multiplexer modules.

Safety Interlock

The Analog Buses of the 34980A are capable of carrying 300V signals. The MUX modules have a hardware *Safety Interlock* feature that automatically opens the Analog Bus relays when the associated interlock pins on the D-sub connectors (faceplate) lose continuity. This prevents signals on the Analog Buses from being present on the D-sub connector pins. Optional terminal blocks available from Keysight automatically provide continuity for these interlock pins. If cables are used, you must provide continuity for the interlock pins in your DUT assembly. See the pinout information later in this guide for the location of interlock pins on each module.

The MUX modules have Analog Bus relays on each of their two banks. Therefore, the interlock pins are present on both the Bank 1 and Bank 2 D-sub connectors on the MUX modules.

Normally, if you attempt to connect to the Analog Buses without a terminal block or cable connected, an error is generated. The

`SYSTEM:ABUS:INTerlock:SIMulate` command allows you to temporarily disable errors generated by the Safety Interlock feature and enables the simulation mode. Although Safety Interlock errors are suppressed in this mode, the actual Analog Bus relays affected by the Safety Interlock are disabled as long as no terminal block or cable is connected to the module.

CAUTION

The Safety Interlock feature is implemented in hardware on the modules and cannot be circumvented. Regardless of whether the simulation mode is enabled or disabled, all Analog Bus connections are prohibited as long as no terminal block or properly-wired cable is connected to the module.

- The simulation mode applies to the entire mainframe and cannot be selectively used on individual modules.
- When the simulation mode is enabled, the Analog Bus relays will *appear* to close and open as directed. For example, no errors are generated if you close an Analog Bus relay from the front panel, remote interface, or Web Interface. However, remember that the Safety Interlock feature prevents the actual hardware state of the Analog Bus relays from being changed. When you connect a terminal block or cable to the module, the Analog Bus relays will be closed.
- The simulation setting is stored in volatile memory and will be lost when power is turned off. To re-enable the simulation mode after power has been off, you must send the command again.

SCPI Programming Examples for the Multiplexer Modules

The programming examples below provide you with SCPI command examples to use for actions specific to the MUX modules.

The slot and channel addressing scheme used in these examples follow the form `sccc` where `s` is the mainframe slot number (1 through 8) and `ccc` is the three-digit channel number. For information on specific MUX channel configurations, refer to the simplified schematics contained in each MUX section of this manual.

For complete information on the SCPI commands used to program the 34980A, with example programs, refer to the *Keysight 34980A Programmer's Reference* contained on the *34980A Product Reference CD*.

Opening and Closing Channels

Example – Closing and opening channels on the armature and reed MUX modules: This command closes the specified channels on a MUX module. If any channel in a bank is defined to be part of the scan list, and a scan is occurring, attempting to close another channel (including Analog Bus channels) within the same bank will result in an error. Channel closures in the other bank are allowed as long as no channels are part of the scan list.

The following commands close and open channels 13 and 15 through 18 in slot 3.

```
ROUTE:CLOSE (@3013,3015:3018)
ROUTE:OPEN (@3013,3015:3018)
```

Example –Closing channels on the FET MUX module: The FET MUX module supports a 1:N type closure, meaning that you can have only one channel per bank closed at a time. The following command closes then automatically opens each channel from 1-19 (Bank 1) in succession, leaving channel 20 closed. Then the command continues closing and opening channels 21 to 39 (Bank 2), then leaving channel 40 closed.

At the end, only channels 20 and 40 will be closed, while all other channels will have been closed and then opened. In this process, a channel will open before the next channel in succession closes, making this a “break-before-make” series.

```
ROUTE:CLOSE (@3001:3040)
```

The following command opens the closed channel on Bank 1 of a FET MUX module in slot 3, and closes channel 15 on that bank.

```
ROUTE:CLOSE (@3015)
```

Example - Closing and opening Analog Bus relays: The following command connects the Analog Buses to Bank 1 (via the Analog Bus relays on Bank 1) for a module in slot 3.

```
ROUTE:CLOSE (@3911,3912,3913,3914)
ROUTE:OPEN (@3911,3912,3913,3914)
```

The Analog Bus relays (numbered s911, s912, s913, etc.) on the MUX modules are ignored if they are included in a range of channels.

An error will be generated if an Analog Bus relay is specified as the first or last channel in a range of channels. For example, the following command closes all valid channels between channel 30 (slot 1) and channel 5 (slot 2). In addition, this command closes Analog Bus relay 911 on the module in slot 1 (Bank 1). Note that although the specified range of channels includes the other Analog Bus relays, they are ignored and are not closed by this command.

```
ROUTE:CLOSE (@1030:2005,1911)
```

Example - Querying channels for open or close state: The following command returns a 1 (true) or 0 (false) state of channel 036 for a module in slot 3.

```
ROUTE:CLOSE (@3036)
ROUTE:CLOSE? (@3036) !Returns a 1
ROUTE:OPEN? (@3036) !Returns a 0
```

Making Measurements

Example - Making voltage measurements: The following command configures channels 9 and 10 in slot 4 for DC voltage measurements, triggers the internal DMM to scan channels 9 and 10, and returns the reading.

The 1 V range is selected with 1 mV resolution.

```
MEASURE:VOLTage:DC? 1,0.001, (@4009,4010)
```

Example - Making voltage measurements using INITiate and FETCh?:

The following program segment shows how to use the **INITiate** command with the **CONFigure** and **FETCh?** commands. The **ROUTE:SCAN** command puts channels 3 and 8 (of a module in slot 1) into the scan list (and redefines the scan list). The **INITiate** command scans the specified channels, and then sends the readings to memory. The **FETCh?** command transfers the readings from memory to the user.

```
CONFigure:VOLTage:DC 10,0.003, (@1003,1008)
ROUTE:SCAN (@1003,1008)
INITiate
FETCh?
```

Example - Making current measurements: The following command configures channel 43 for a 34921A modules in slot 7 for dc current measurements, triggers the internal DMM to scan the channel, and then sends the reading to the output buffer of the 34980A. The default settings for range (autorange) and resolution (1 PLC) are used for the measurement.

```
MEASURE:CURRENT:DC? (@7043)
```

Configuring a Module

Example - Configuring a module for 2-wire or 1-wire mode: The following command configures a MUX module in slot 4 for 1-wire mode. Because you can configure only the 34923A and 34925A MUX modules (and the 34933A matrix module) for either 2-wire or 1-wire mode, an error is generated if you send this command to a slot that does not contain one of those three modules. If you are using terminal blocks with these modules, be sure to use the corresponding 2-wire or 1-wire terminal block.

```
SYSTem:MODUle:WIRE:MODE WIRE1,4
```

NOTE

When using a command to configure the system, the new configuration does not take effect until you cycle power on the 34980A.

Example - Querying the system for module Identify: The following command returns the identity of the module installed in slot 7.

```
SYSTem:CTYPe? 7
```

NOTE

For the 34923A and the 34925A MUX modules, the query response may include a suffix to indicate a 1-wire configuration. For example, the response for the 34923A will be either "34923A" (differential mode) or "34923A-1W" (single-ended mode).

Querying and Clearing Cycle Count, and Resetting Modules

Example - Querying the cycle count for a relay: The following command returns the cycle count on channel 7 and channel 16 for a MUX module in slot 1.

```
DIAGnostic:RELay:CYCLes? (@1007,1016)
```

NOTE

The 34925A will return 0 for relay counts because the FET relays on that module are non-mechanical and have an undefined lifetime.

Example - Clearing the cycle count for a relay: The following command resets the cycle count to zero on the channels 7 and 16 for a MUX module in slot 1.

```
DIAGnostic:RELay:CYCLes:CLEar (@1007,1016)
```

Example - Resetting module(s) to power-on state: The following command resets a module in slot 4 to its power-on state.

```
SYSTem:CPON 4
```

34921A 40-Channel Armature Multiplexer with Low Thermal Offset

The 34921A 40-Channel Armature Multiplexer (40-Ch Arm MUX) is divided into two banks with 20 latching armature switches (channels 1-20 and 21-40) in each. This module also offers four additional fused relays (channels 41-44) for making AC and DC current measurements with the internal DMM with no external shunts needed. These current channels feature “make-before-break” connections to ensure continuous current flow when switching from one current channel to another. The current fuses are replaceable. Refer to the *34980A Service Guide* for specific information about these fuses.

This module also contains nine armature Analog Bus relays (channels 911-914, 921-924, and 931), four on each bank that can connect the bank relays to the system Analog Buses and one that connects the current relays to the current input of the DMM. Through ABus1 and ABus2 you can connect any of the channels to the internal DMM for voltage or resistance measurements. Refer to the simplified schematic on [page 17](#).

NOTE

ABus1 consists of three wires that are used for current and voltage measurements. A separate current bus on ABus1 connects to the internal DMM current measurement input and this bus can be connected only to channels 41 through 44. The current channel low (L) signal path is common with the ABus1 low (L) signal path.

You cannot measure current and voltage on ABus1 simultaneously.

Using program commands or the mainframe front panel, you can control each of the channel switches individually, and thus configure the 34921A module in these modes:

- two independent 20-channel 2-wire MUXes. This configuration requires neither using external wiring nor connecting through the internal Analog Buses.
- one 20-channel 4-wire MUX. This configuration requires neither using external wiring nor connecting through the internal Analog Buses. For 4-wire resistance measurements, the instrument automatically pairs channel n on Bank 1 (source) with channel $n+20$ on Bank 2 (sense) to provide these connections. Four-wire controls occur only when doing 4-wire measurement operations through the internal DMM, such as `MEASure:FRESistance?` or scanning a channel previously configured as 4-wire.

- one 40-channel 2-wire MUX. You must use external wiring or connect through the internal Analog Bus relays for this configuration. For example, closing Analog Bus channels 913 and 923 connects Bank 1 and Bank 2 through ABus3. Or, externally you can connect COM1 to COM2 to create this configuration.

Low thermal offset voltage makes the 34921A ideal for low-level signal switching. The 34921T optional terminal block provides a built-in thermocouple reference junction that helps minimize errors due to thermal offset when you measure thermocouples.

This module has capability to scan as many as 100 channels/second using the internal DMM. With the automatic “break-before-make” connection operation, you are assured that no two signals are connected to each other during a scan. When using the module in a non-scanning mode, you can close as many channels as you wish.

This module is safety interlock protected, which means whenever the D-sub connector end of the modules is exposed, the Analog Bus relays automatically open and disconnect from the Analog Bus. For more information, see “[Safety Interlock](#)” on page 11 and “[34921A D-Sub Connectors](#)” on page 18.

When power is off, all channel relays maintain state, and the Analog Bus relays open.

34921A Simplified Schematic

This drawing shows two independent 20-channel 2-wire MUXes.

NOTE

The three-digit number assigned to each switch represents the channel number.

Bank Relays: Armature latching; Analog Bus Relays: Armature non-latching

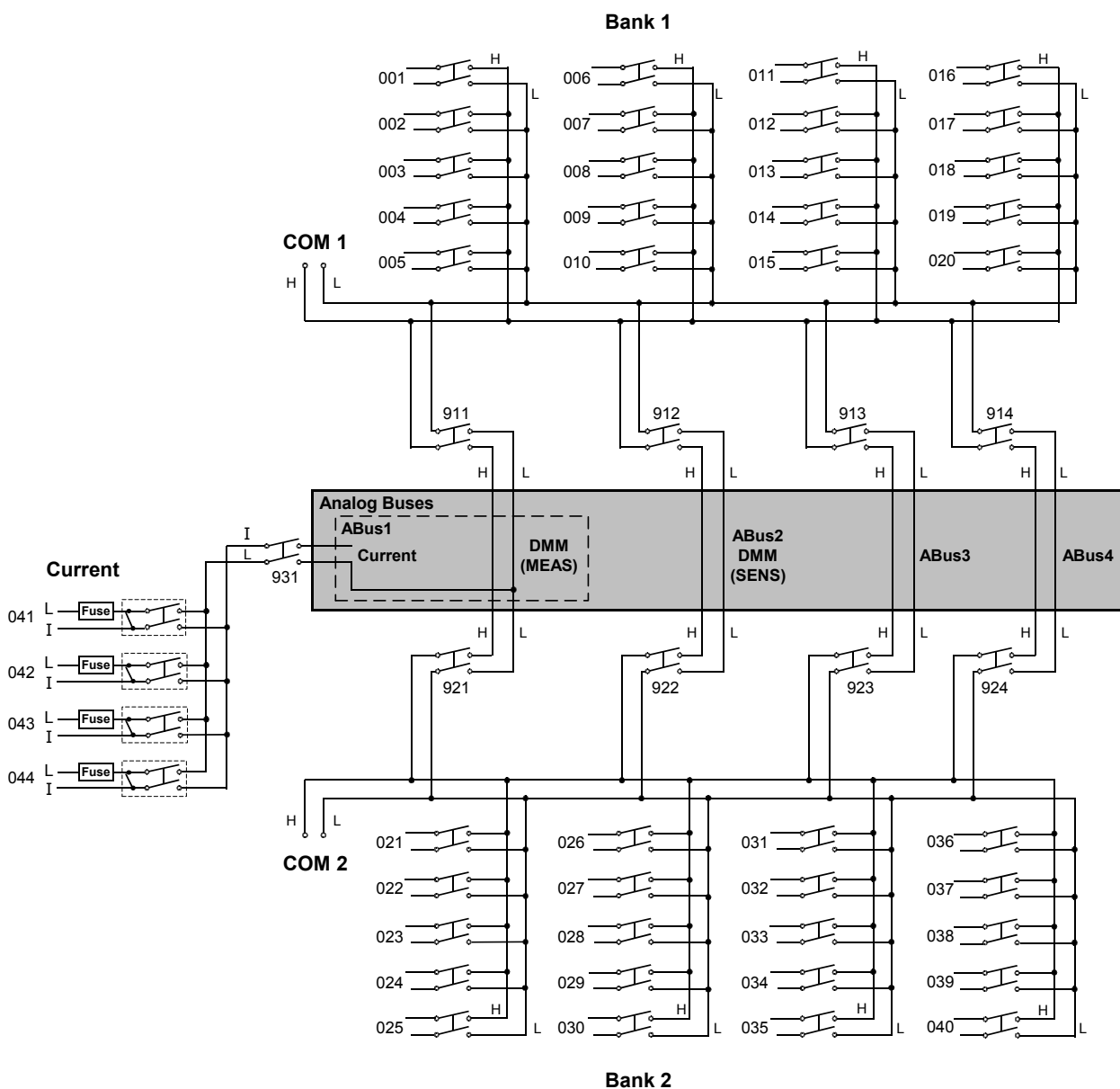

34921A D-Sub Connectors

Bank 1

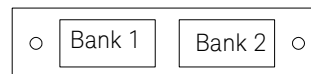

For orientation, the D-sub connector end of the module is

*TSIL = Temperature Sensor Interface Line. Provides thermocouple reference sensor serial output line to the mainframe processor.

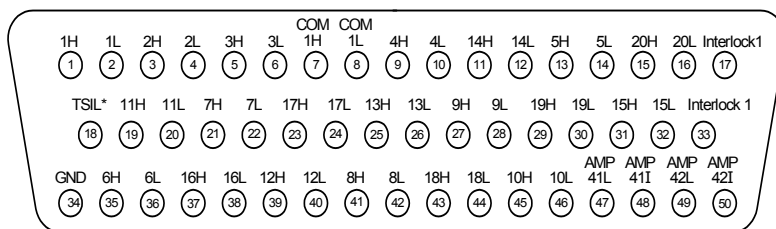

50-Pin D-Sub Male Connector

Desc	Pin	Desc	Pin	Desc	Pin	Desc	Pin	Desc	Pin
1H	1	6H	35	11H	19	16H	37	COM1 H	7
1L	2	6L	36	11L	20	16L	38	COM1 L	8
2H	3	7H	21	12H	39	17H	23	Interlock 1	17
2L	4	7L	22	12L	40	17L	24	Interlock 1	33
3H	5	8H	41	13H	25	18H	43	GND	34
3L	6	8L	42	13L	26	18L	44	TSIL*	18
4H	9	9H	27	14H	11	19H	29	AMP 41L	47
4L	10	9L	28	14L	12	19L	30	AMP 41I	48
5H	13	10H	45	15H	31	20H	15	AMP 42L	49
5L	14	10L	46	15L	32	20L	16	AMP 42I	50

WARNING

As a safety feature, interlock 1 pins (17 and 33) on Bank 1 must be shorted to enable the Bank 1 Analog Bus relays to close. The optional 34921T terminal block shorts these pins for you. This feature protects inadvertent routing of high voltages from the Analog Bus to the D-sub connector of the module.

Bank 2

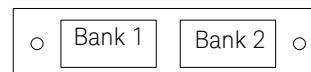

For orientation, the D-sub connector end of the module is facing you.

*TSIL = Temperature Sensor Interface Line. Provides thermocouple reference sensor serial output line to the mainframe processor.

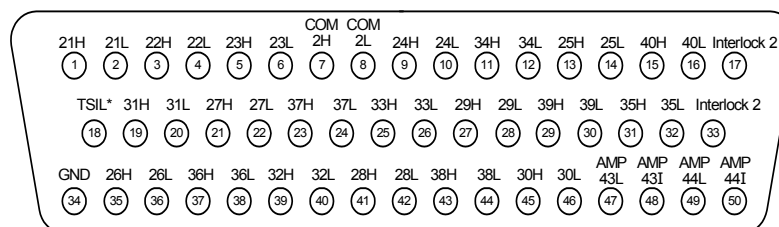

50-Pin D-Sub Male Connector

Desc	Pin	Desc	Pin	Desc	Pin	Desc	Pin	Desc	Pin
21H	1	26H	35	31H	19	36H	37	COM2 H	7
21L	2	26L	36	31L	20	36L	38	COM2 L	8
22H	3	27H	21	32H	39	37H	23	Interlock 2	17
22L	4	27L	22	32L	40	37L	24	Interlock 2	33
23H	5	28H	41	33H	25	38H	43	GND	34
23L	6	28L	42	33L	26	38L	44	TSIL*	18
24H	9	29H	27	34H	11	39H	29	AMP 43L	47
24L	10	29L	28	34L	12	39L	30	AMP 43I	48
25H	13	30H	45	35H	31	40H	15	AMP 44L	49
25L	14	30L	46	35L	32	40L	16	AMP 44I	50

WARNING

As a safety feature, interlock 2 pins (17 and 33) on Bank 2 must be shorted to enable the Bank 2 Analog Bus relays to close. The optional 34921T terminal block shorts these pins for you. This feature protects inadvertent routing of high voltages from the Analog Bus to the D-sub connector of the module.

34921T Terminal Block

This terminal block with screw-type connections is labeled with the model number and the abbreviated module name. In addition, space is available on the label for you to write the slot number.

NOTE All modules that connect to the internal DMM are interlock protected. This means that when an installed module is exposed (no terminal block or cable is connected), the Analog Bus relays are open and disconnected from the Analog Buses. See “Safety Interlock” on page 11 for further information.

The 34921T is the only terminal block that provides an isothermal block with temperature reference for thermocouple measurements. The temperature sensor is located on the bottom side of the PC board as shown below. Also shown are two holes that you can use for connecting an external temperature reference to the terminal block.

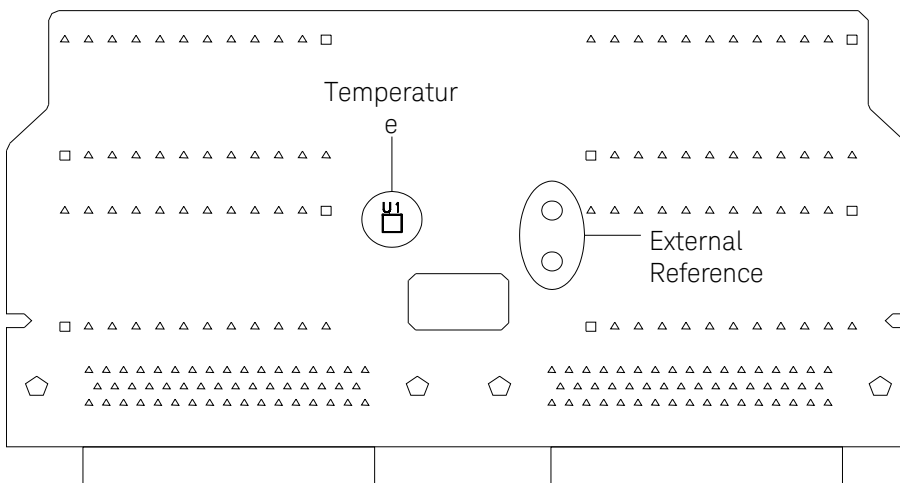

34921T (viewed from bottom side)

CAUTION When wiring the terminal block via cables to the mainframe, make sure the cables are connected to the correct connector. The cables provide communication and power to the temperature sensor on the 34921T terminal block. If cabling is not correct, an error may occur indicating that the 34921A module is not fully operational.

The 34980A Product Reference CD (shipped with the instrument) contains a 34921T Wiring Log for you to document your wiring configuration for this module. You can open the wiring log file in Microsoft® Excel® or Adobe® Acrobat® format.

Wire Size:
20 AWG Typical
18 AWG Max

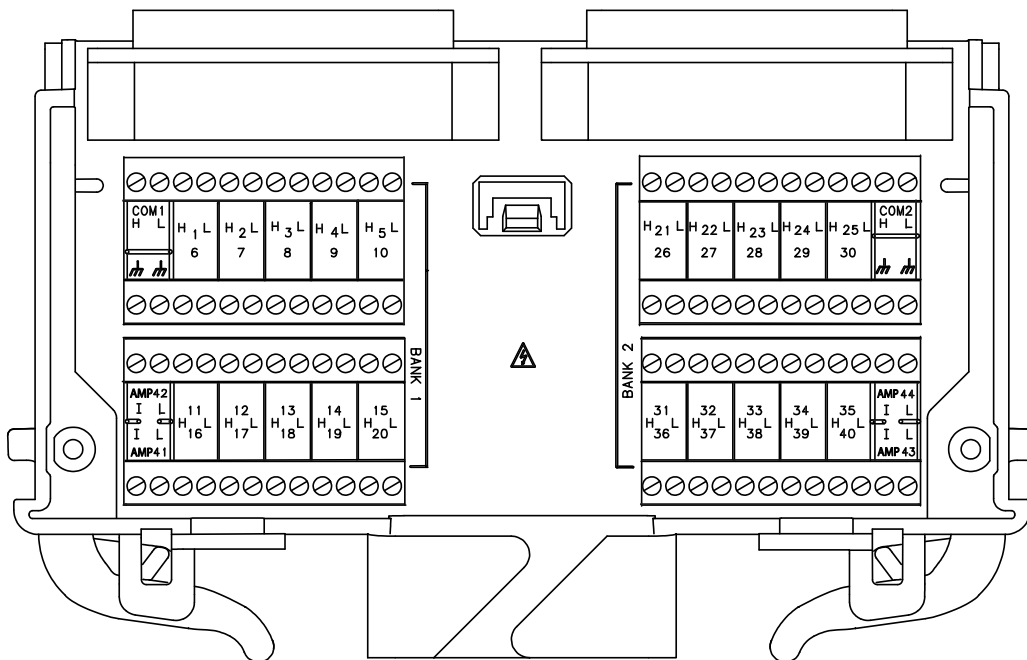

34922A 70-Channel Armature Multiplexer

The high-density 34922A 70-Channel Armature Multiplexer (70-Ch Arm MUX) is divided into two banks with 35 latching armature switches (channels 1-35 and 36-70) in each. This module also contains eight armature Analog Bus relays (channels 911-914 and 921-924), four on each bank that can connect the bank relays to the system Analog Buses. Through ABus1 and ABus2 you can connect any of the channels to the internal DMM for voltage or resistance measurements. Refer to the simplified schematic on [page 23](#).

Using program commands or the mainframe front panel, you can control each of the channel switches individually, and thus configure the 34922A in these modes:

- two independent 35-channel 2-wire MUXes. This configuration requires neither using external wiring nor connecting through the internal Analog Buses.
- one 35-channel 4-wire MUX. This configuration requires neither using external wiring nor connecting through the internal Analog Buses. For 4-wire resistance measurements, the instrument automatically pairs channel n on Bank 1 (source) with channel $n+35$ on Bank 2 (sense) to provide these connections. Four-wire controls occur only when doing 4-wire measurement operations through the internal DMM, such as `MEASure:FRESistance?` or scanning a channel previously configured as 4-wire.
- one 70-channel 2-wire MUX. You must use external wiring or connect through the internal Analog Bus relays for this configuration. For example, closing Analog Bus channels 913 and 923 connects Bank 1 and Bank 2 through ABus3. Or, externally you can connect COM1 to COM2 to create this configuration.

This module has capability to scan as many as 100 channels/second using the internal DMM. With the automatic “break-before-make” connection operation, you are assured that no two signals are connected to each other during a scan. When using the module in a non-scanning mode, you can close as many channels as you wish.

This module is interlock protected, which means whenever the D-sub connector end of the modules is exposed, the Analog Bus relays automatically open and disconnect from the Analog Bus. For more information, see “[Safety Interlock](#)” on page 11 and “[34922A D-Sub Connectors](#)” on page 24.

When the power is off, all channel relays maintain state, and the Analog Bus relays open.

34922A Simplified Schematic

This drawing shows two independent 35-channel 2-wire MUXes.

NOTE

The three-digit number assigned to each switch represents the channel number.

Bank Relays: Armature latching; Analog Bus Relays: Armature non-latching

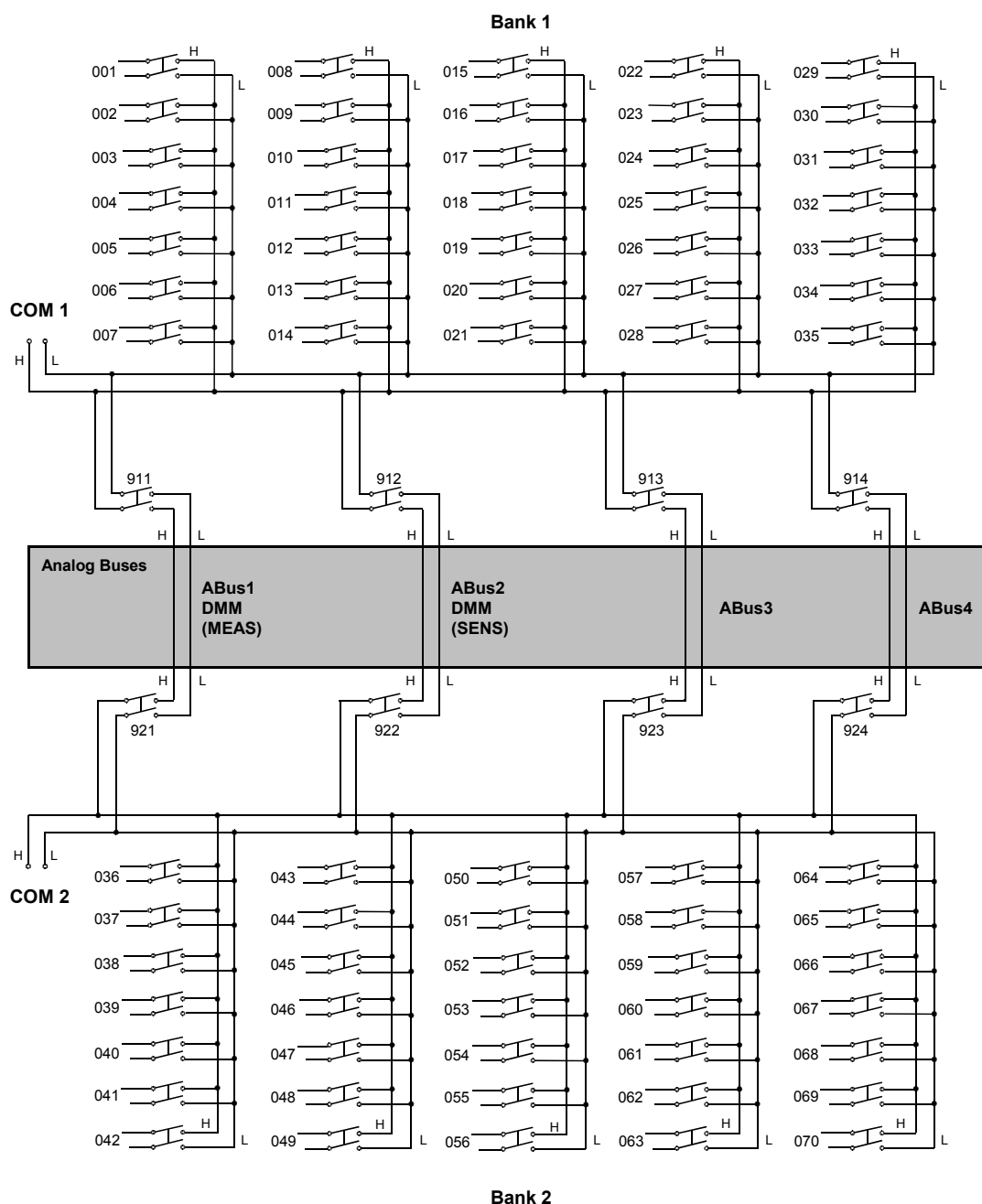

34922A D-Sub Connectors

Bank 1

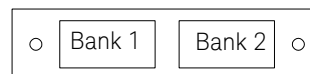

For orientation, the D-sub connector end of the module is facing you.

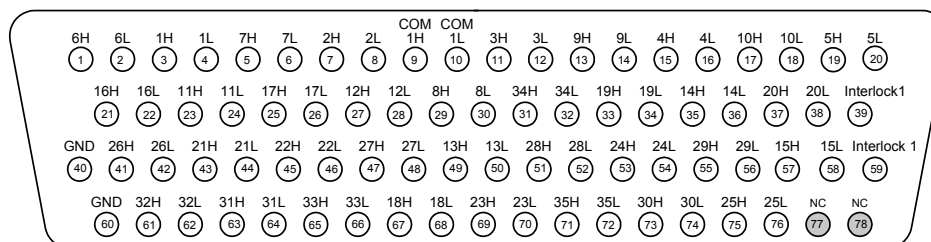

78-Pin D-Sub Male Connector

Desc	Pin	Desc	Pin	Desc	Pin	Desc	Pin	Desc	Pin	Desc	Pin
1H	3	8H	29	15H	57	22H	45	29H	55	COM1 H	9
1L	4	8L	30	15L	58	22L	46	29L	56	COM1 L	10
2H	7	9H	13	16H	21	23H	69	30H	73	Interlock 1	39
2L	8	9L	14	16L	22	23L	70	30L	74	Interlock 1	59
3H	11	10H	17	17H	25	24H	53	31H	63	GND	40
3L	12	10L	18	17L	26	24L	54	31L	64	GND	60
4H	15	11H	23	18H	67	25H	75	32H	61	No Connect	77
4L	16	11L	24	18L	68	25L	76	32L	62	No Connect	78
5H	19	12H	27	19H	33	26H	41	33H	65		
5L	20	12L	28	19L	34	26L	42	33L	66		
6H	1	13H	49	20H	37	27H	47	34H	31		
6L	2	13L	50	20L	38	27L	48	34L	32		
7H	5	14H	35	21H	43	28H	51	35H	71		
7L	6	14L	36	21L	44	28L	52	35L	72		

WARNING

As a safety feature, interlock 1 pins (39 and 59) on Bank 1 must be shorted to enable the Bank 1 Analog Bus relays to close. The optional 34922T terminal blocks short these pins for you. This feature protects inadvertent routing of high voltages from the Analog Buses to the D-sub connector of the module.

Bank 2

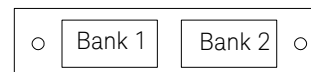

For orientation, the D-sub connector end of the module is facing you.

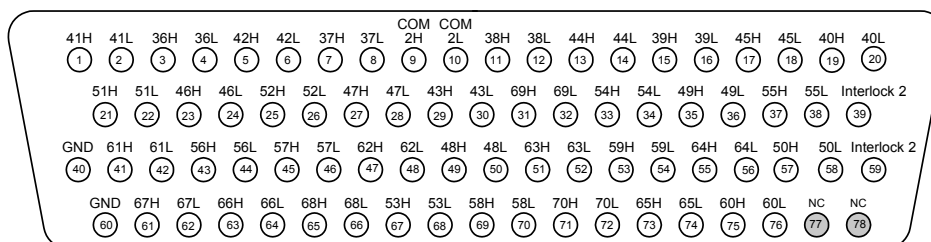

78-Pin D-Sub Male Connector

Desc	Pin	Desc	Pin	Desc	Pin	Desc	Pin	Desc	Pin	Desc	Pin
36H	3	43H	29	50H	57	57H	45	64H	55	COM2 H	9
36L	4	43L	30	50L	58	57L	46	64L	56	COM2 L	10
37H	7	44H	13	51H	21	58H	69	65H	73	Interlock 2	39
37L	8	44L	14	51L	22	58L	70	65L	74	Interlock 2	59
38H	11	45H	17	52H	25	59H	53	66H	63	GND	40
38L	12	45L	18	52L	26	59L	54	66L	64	GND	60
39H	15	46H	23	53H	67	60H	75	67H	61	No Connect	77
39L	16	46L	24	53L	68	60L	76	67L	62	No Connect	78
40H	19	47H	27	54H	33	61H	41	68H	65		
40L	20	47L	28	54L	34	61L	42	68L	66		
41H	1	48H	49	55H	37	62H	47	69H	31		
41L	2	48L	50	55L	38	62L	48	69L	32		
42H	5	49H	35	56H	43	63H	51	70H	71		
42L	6	49L	36	56L	44	63L	52	70L	72		

WARNING

As a safety feature, interlock 2 pins (39 and 59) on Bank 2 must be shorted to enable the Bank 2 Analog Bus relays to close. The optional 34922T terminal blocks short these pins for you. This feature protects inadvertent routing of high voltages from the Analog Buses to the D-sub connector of the module.

34922T Terminal Blocks

Two terminal blocks are available to facilitate wiring connections to the 34922A module:

34922T-001 (Option 001)	Terminal block with solder connectors
34922T-002 (Option 002)	Terminal block with screw connectors

The 34980A Product Reference CD (shipped with the instrument) contains a 34922T Wiring Log for you to document your wiring configuration for this module. You can open the wiring log file in Microsoft® Excel® or Adobe® Acrobat® format.

NOTE All modules that connect to the internal DMM are interlock protected. This means that when an installed module is exposed (no terminal block or cable is connected), the Analog Bus relays are open and disconnected from the Analog Buses. See “Safety Interlock” on page 11 for further information.

34922T-001 Terminal Block

This terminal block with solder-type connections is labeled with the model number and the abbreviated module name. In addition, space is available on the label for you to write the slot number.

Wire Size:
20 AWG
Typical

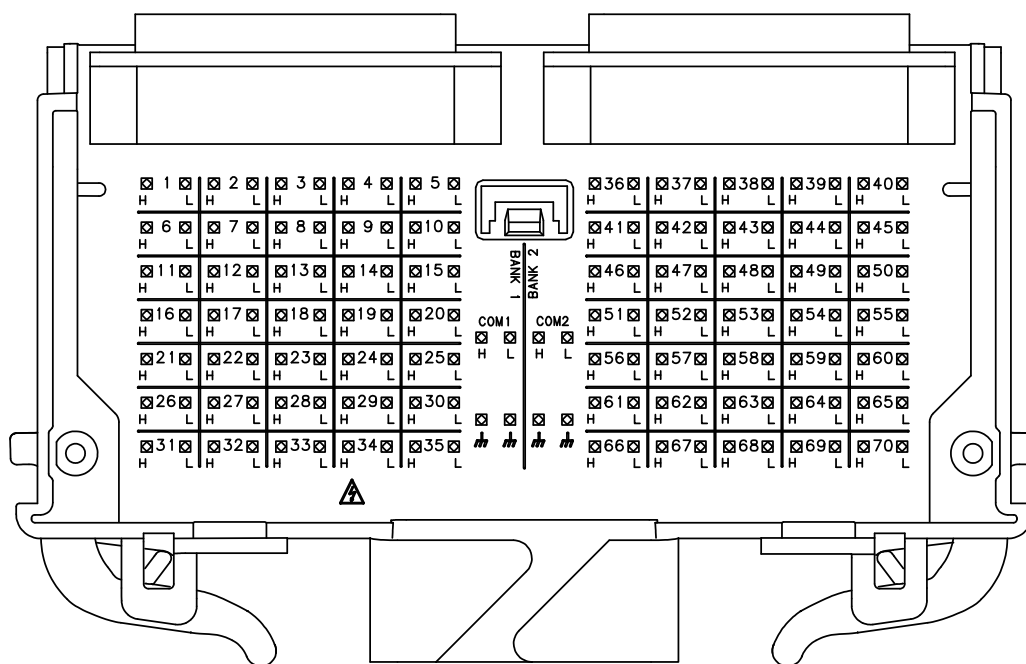

34922T-002 Terminal Block

This terminal block with screw-type connections is labeled with the model number and the abbreviated module name. In addition, space is available on the label for you to write the slot number.

Wire Size:
22 AWG Typical
20 AWG Max

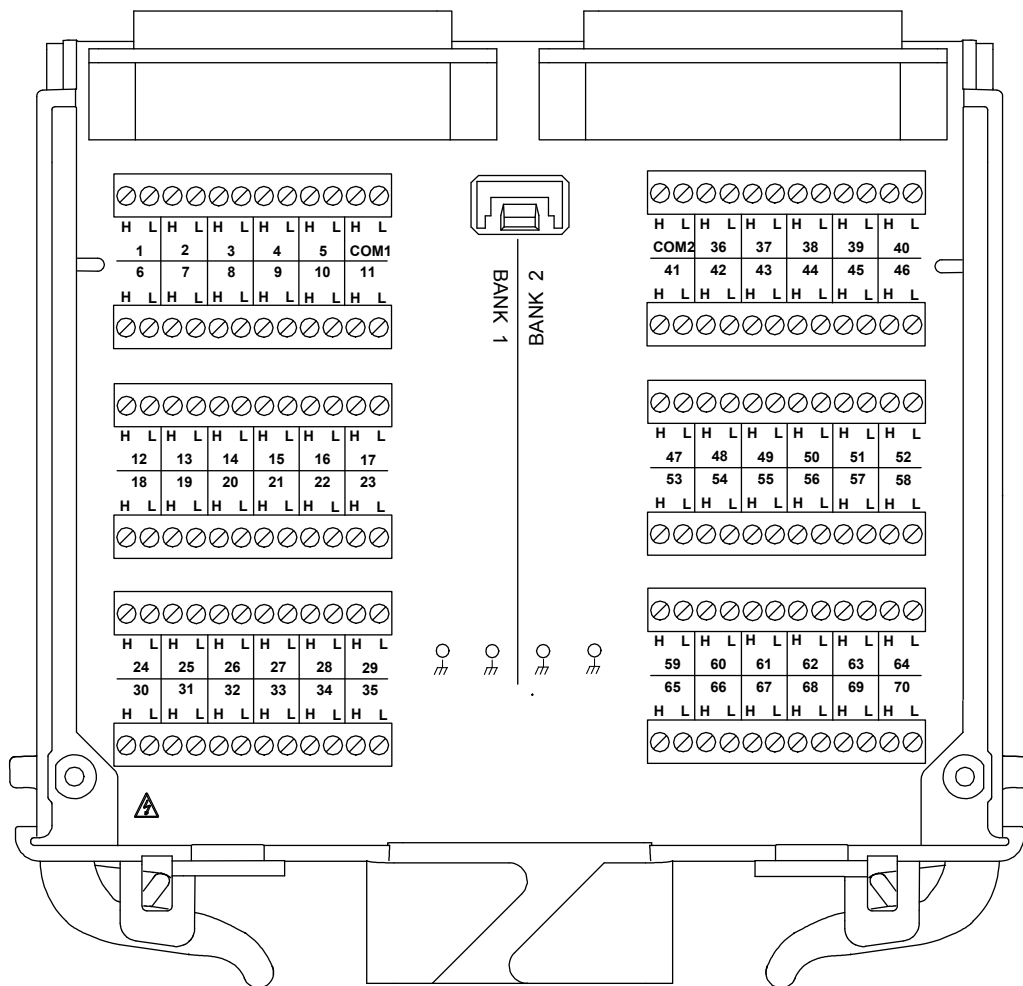

34923A 40/80-Channel Reed Multiplexer

The 34923A 40/80-Channel Reed Multiplexer (40/80-Ch Reed MUX) is divided into two equal banks of non-latching reed switches. This module also contains eight armature Analog Bus relays (channels 911-914 and 921-924), four on each bank that can connect the bank relays to the system Analog Buses. You can connect any of the channels to the internal DMM through ABus1 and ABus2 for voltage or resistance measurements.

Using program commands or the mainframe front panel, you can control each of the channel switches individually, and configure this module for differential (2-wire or 4-wire) or single-ended (1-wire) mode. Refer to the simplified schematics on [page 31](#) and [page 35](#).

If you are using an Keysight 34923T-00x terminal block to connect your DUT to this module, be sure to use the terminal block that corresponds to your module configuration mode (Refer to the terminal block drawings on [page 34](#) and [page 38](#)):

34923T-001 (Option 001)	Terminal block for differential (two- or four-wire) mode
34923T-002 (Option 002)	Terminal block for single-ended (1-wire) mode

You can confirm the mode in which your module is configured by using the `SYSTEM:CTYPE? <slot number>` program command. This command returns the identity of the plug-in module in the specified slot.

NOTE

Whenever you change from 2- or 4-wire mode to 1-wire mode, or the reverse, you must cycle power on the 34980A for the configuration to take effect.

In all modes, this module has capability to scan as many as 500 channels/second using the internal DMM. With the automatic “break-before-make” connection operation, you are assured that no two signals are connected to each other during a scan.

This module is interlock protected, which means whenever the D-sub connector end of the modules is exposed, the Analog Bus relays immediately open and disconnect from the Analog Bus. For more information, see “[Safety Interlock](#)” on page 11 and the D-Sub connector drawings on [page 32](#) and [page 36](#).

CAUTION

Because user-attached reactive loads and backplane parasitic capacitance may result in high in-rush currents, 100 Ω in-rush resistors protect the reed relays from damage and performance degradation. Therefore, you must consider these resistors when you are designing a measurement. Refer to the simplified schematics on [page 31](#) and [page 35](#).

Lifetime of relays is severely degraded as current or voltage goes up. If higher voltage is being switched, limits on source current are recommended. When the power is off, all channel and Analog Bus relays open.

Two-Wire Mode

You may configure the 34923A as:

- two independent 20-channel 2-wire MUXes. This configuration requires neither the use of external wiring nor connection through the internal Analog Buses.
- one 40-channel, 2-wire MUX. For this configuration, you *must* use external wiring or connect through the internal Analog Buses.

In 2-wire mode, you can close no more than 20 channels simultaneously due to power dissipation. Note that there are two 20 channel banks in 2-wire mode. Each 20 channel bank is further divided into two 10 channel sub-banks in the control circuitry. These 20 channels are split 10 to a bank. However, note that Analog Bus relays count half as much as channel relays in that total. For example, with one Analog Bus relay closed, you can close up to a maximum of 19 channel relays. If you try to close more than the allowed number of channels, you will receive an error message.

Four-Wire Mode

You may configure the 34923A as a 20-channel 4-wire MUX. This configuration requires neither external wiring nor connection through the Analog Buses.

For 4-wire resistance measurements, the instrument automatically pairs channel n on Bank 1 (source) with channel $n+20$ on Bank 2 (sense) to provide these connections. Four-wire controls occur only when doing 4-wire measurement operations through the internal DMM, such as `MEASure:FRESistance?` or scanning a channel previously configured as 4-wire.

One-Wire Mode

You may configure the 34923A as:

- two independent 40-channel 1-wire MUXes. This configuration requires neither external wiring nor connection through the internal Analog Buses.
- one 80-channel 1-wire MUX. You must use external wiring or connect through the internal Analog Bus for this configuration.

NOTE

Because all bank relays supply only HI signals, you can apply a LOW signal through COM1 L or COM2 L when you are making 2-wire resistance measurements in 1-wire mode.

In 1-wire mode, you can close no more than 40 channels simultaneously due to power dissipation. Note that there are two 40 channel banks in 1-wire mode. Each 40 channel bank is further divided into two 20 channel sub-banks in the control circuitry. These channels are split 20 to a bank. For example, with one

Analog Bus relay closed you can close up to a maximum of 39 channel relays. If you try to close more than the allowed number of channels, you will receive an error message.

34923A Simplified Schematic for Two- or Four-Wire Mode

This drawing shows two independent 20-channel 2-wire MUXes.
To change configuration modes, use the `SYSTem:MODuLe:WIRE:MODE` command.

NOTE

The three-digit number assigned to each switch represents the channel number.

Bank Relays: Reed non-latching; Analog Bus Relays: Armature non-latching

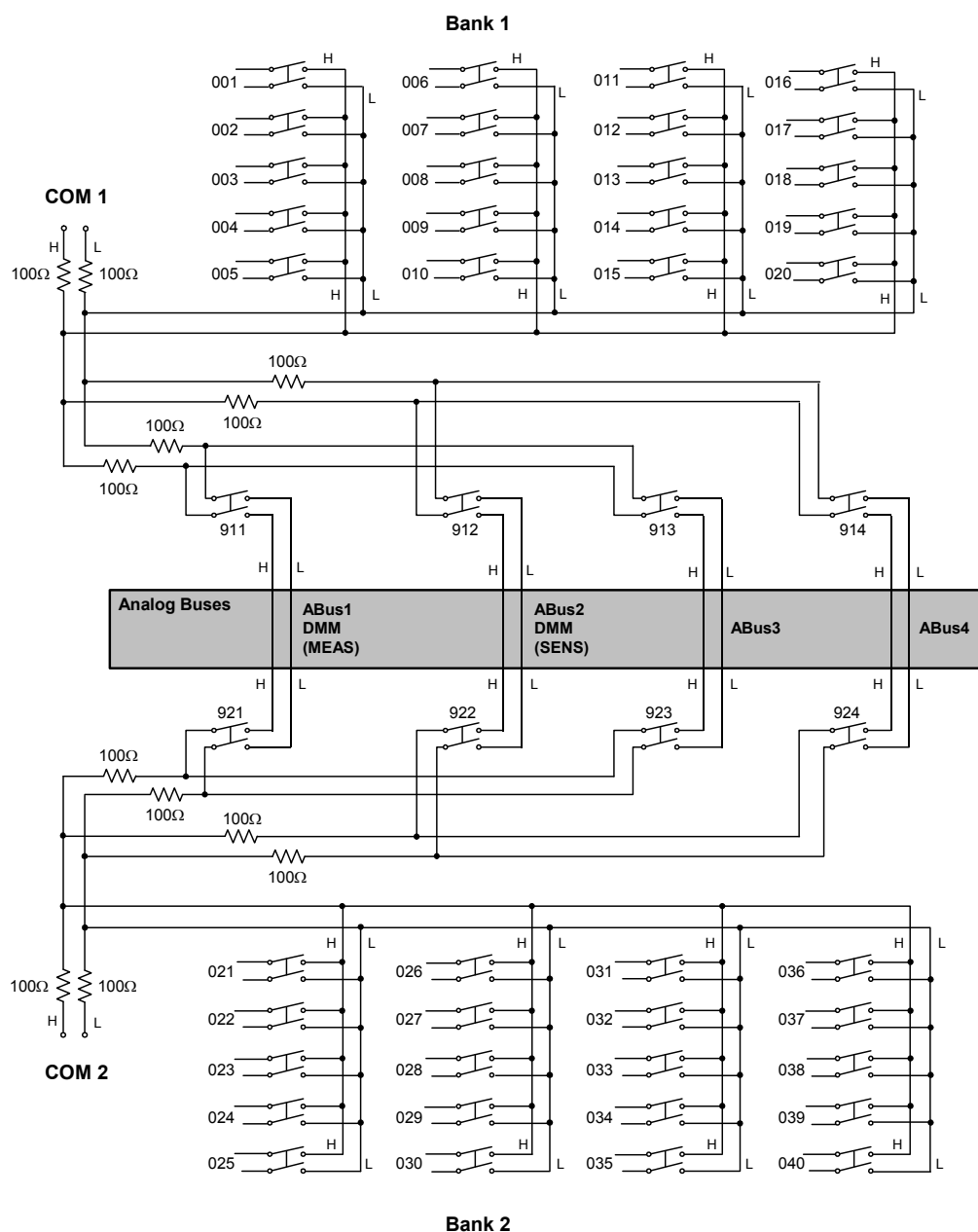

34923A D-Sub Connectors for Two- or Four-Wire Mode

Bank 1

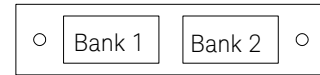

For orientation, the D-sub connector end of the module is facing you.

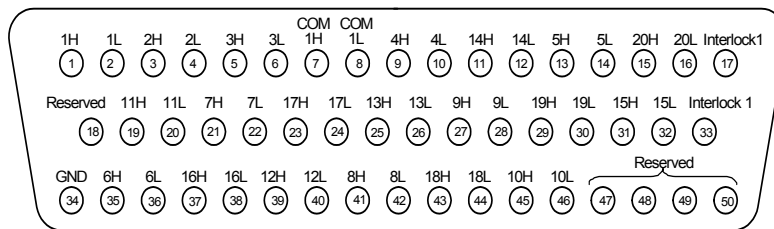

50-Pin D-Sub Male Connector

Desc	Pin	Desc	Pin	Desc	Pin	Desc	Pin	Desc	Pin
1H	1	6H	35	11H	19	16H	37	COM1 H	7
1L	2	6L	36	11L	20	16L	38	COM1 L	8
2H	3	7H	21	12H	39	17H	23	Interlock 1	17
2L	4	7L	22	12L	40	17L	24	Interlock 1	33
3H	5	8H	41	13H	25	18H	43	GND	34
3L	6	8L	42	13L	26	18L	44	Reserved	18
4H	9	9H	27	14H	11	19H	29	Reserved	47
4L	10	9L	28	14L	12	19L	30	Reserved	48
5H	13	10H	45	15H	31	20H	15	Reserved	49
5L	14	10L	46	15L	32	20L	16	Reserved	50

WARNING

As a safety feature, interlock 1 pins (17 and 33) on Bank 1 must be shorted to enable the Bank 1 Analog Bus relays to close. The optional 34923T-001 (for 2-wire) terminal block shorts these pins for you. This feature protects inadvertent routing of high voltages from the Analog Bus to the D-sub connector of the module.

Bank 2

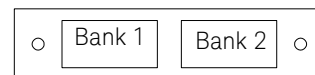

For orientation, the D-sub connect end of the module is facing you.

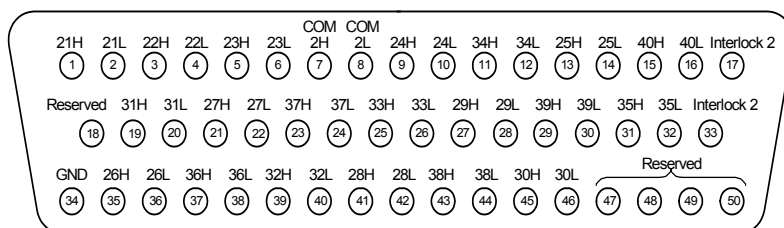

50-Pin D-Sub Male Connector

Desc	Pin	Desc	Pin	Desc	Pin	Desc	Pin	Desc	Pin
21H	1	26H	35	31H	19	36H	37	COM2 H	7
21L	2	26L	36	31L	20	36L	38	COM2 L	8
22H	3	27H	21	32H	39	37H	23	Interlock 2	17
22L	4	27L	22	32L	40	37L	24	Interlock 2	33
23H	5	28H	41	33H	25	38H	43	GND	34
23L	6	28L	42	33L	26	38L	44	Reserved	18
24H	9	29H	27	34H	11	39H	29	Reserved	47
24L	10	29L	28	34L	12	39L	30	Reserved	48
25H	13	30H	45	35H	31	40H	15	Reserved	49
25L	14	30L	46	35L	32	40L	16	Reserved	50

WARNING

As a safety feature, interlock 2 pins (17 and 33) on Bank 2 must be shorted to enable the Bank 2 Analog Bus relays to close. The optional 34923T-001 (for 2-wire) shorts these pins for you. This feature protects inadvertent routing of high voltages from the Analog Buses to the D-sub connector of the module.

34923T-001 Terminal Block for Two-Wire or Four-Wire Mode

This terminal block with screw-type connections is labeled with the model number and the abbreviated module name. In addition, space is available on the label for you to write the slot number.

NOTE All modules that connect to the internal DMM are interlock protected. This means that when an installed module is exposed (no terminal block or cable is connected), the Analog Bus relays are open and disconnected from the Analog Buses. See “Safety Interlock” on page 11 for further information.

NOTE If you are using a Keysight terminal block to connect your DUT to this module be sure to use the 34923T-001 terminal block that corresponds to the 2- or 4-wire configuration mode. An error will not be generated if you have installed a terminal block that doesn't match the present module configuration.

The 34980A Product Reference CD (shipped with the instrument) contains a 34923T (2-wire mode) Wiring Log for you to document your wiring configuration for this module. You can open the wiring log file in Microsoft® Excel® or Adobe® Acrobat® format.

Wire Size:
20 AWG Typical
18 AWG Max

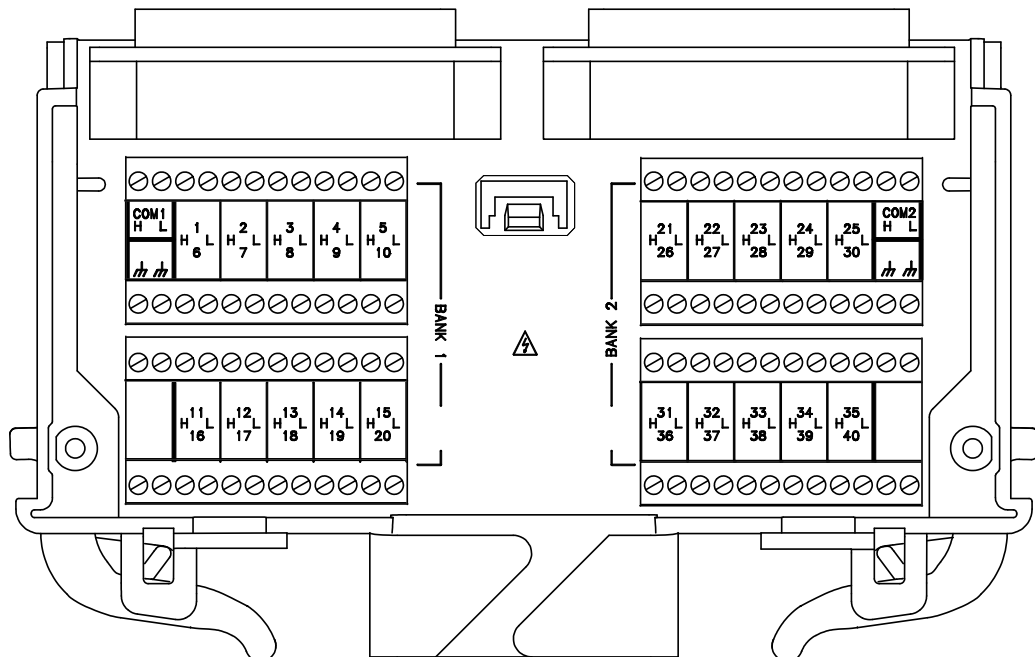

34923A Simplified Schematic for One-Wire Mode

This drawing shows two independent 40-channel 1-wire MUXes. To change configuration modes, use the `SYSTEM:MODULE:WIRE:MODE` command.

NOTE

The three-digit number assigned to each switch represents the channel number.

Bank Relays: Reed non-latching; Analog Bus Relays: Armature non-latching

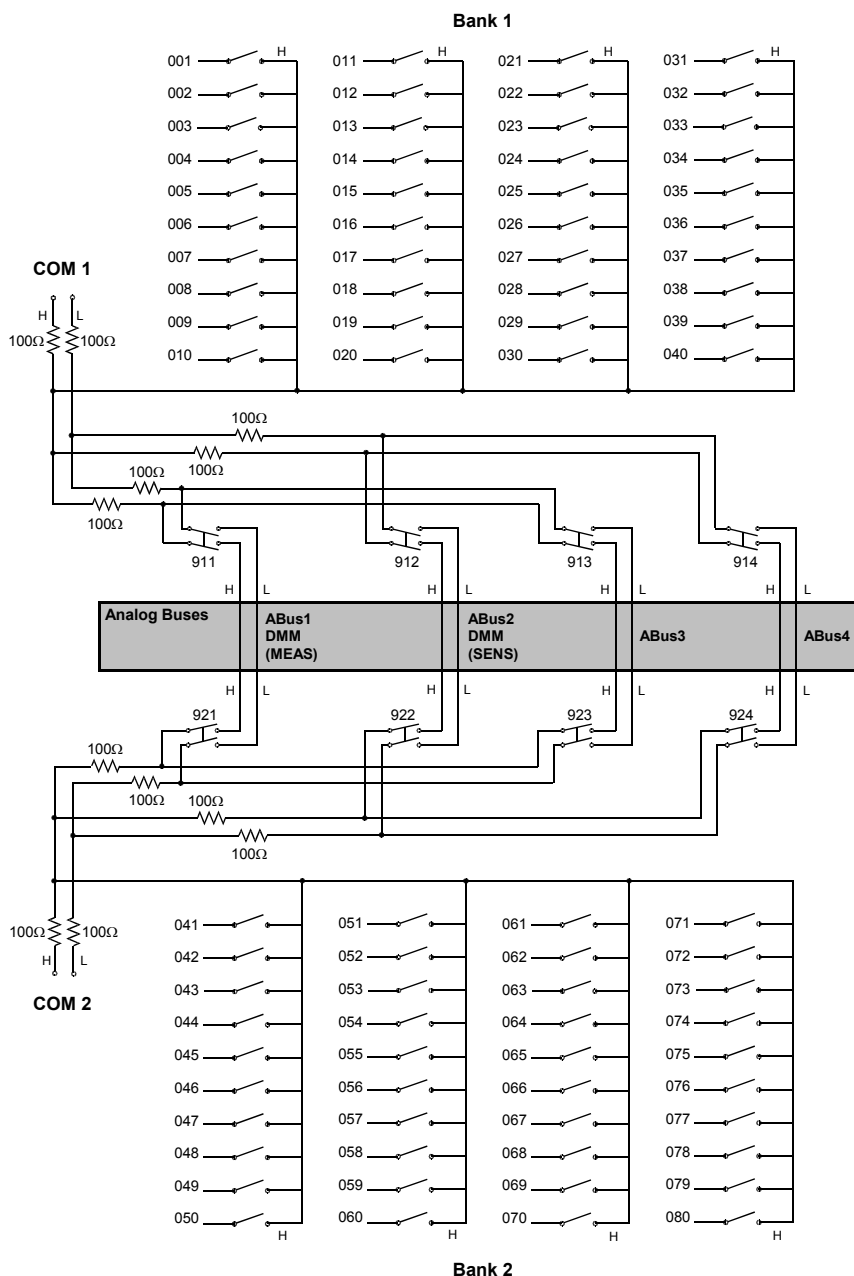

34923A D-Sub Connectors for One-Wire Mode

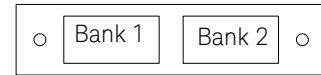

Bank 1

For orientation, the D-sub connector end of the module is facing you.

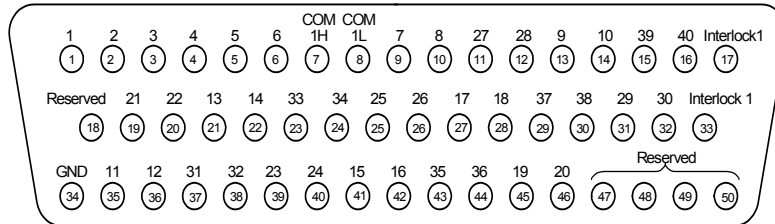

50-Pin D-Sub Male Connector

Desc	Pin	Desc	Pin	Desc	Pin	Desc	Pin	Desc	Pin
1	1	11	35	21	19	31	37	COM1 H	7
2	2	12	36	22	20	31	38	COM1 L	8
3	3	13	21	23	39	33	23	Interlock 1	17
4	4	14	22	24	40	34	24	Interlock 1	33
5	5	15	41	25	25	35	43	GND	34
6	6	16	42	26	26	36	44	Reserved	18
7	9	17	27	27	11	37	29	Reserved	47
8	10	18	28	28	12	38	30	Reserved	48
9	13	19	45	29	31	39	15	Reserved	49
10	14	20	46	30	32	40	16	Reserved	50

WARNING

As a safety feature, interlock 1 pins (17 and 33) on Bank 1 must be shorted to enable the Bank 1 Analog Bus relays to close. The optional 34923T-002 (for 1-wire) shorts these pins for you. This feature protects inadvertent routing of high voltages from the Analog Bus to the D-sub connector of the module.

Bank 2

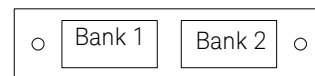

For orientation, the D-sub connector end of the module is facing you.

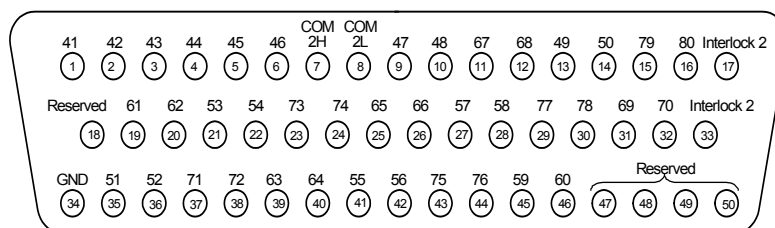

50-Pin D-Sub Male Connector

Desc	Pin	Desc	Pin	Desc	Pin	Desc	Pin	Desc	Pin
41	1	51	35	61	19	71	37	COM2 H	7
42	2	52	36	62	20	72	38	COM2 L	8
43	3	53	21	63	39	73	23	Interlock 2	17
44	4	54	22	64	40	74	24	Interlock 2	33
45	5	55	41	65	25	75	43	GND	34
46	6	56	42	66	26	76	44	Reserved	18
47	9	57	27	67	11	77	29	Reserved	47
48	10	58	28	68	12	78	30	Reserved	48
49	13	59	45	69	31	79	15	Reserved	49
50	14	60	46	70	32	80	16	Reserved	50

WARNING

As a safety feature, interlock pins (17 and 33) on Bank 2 must be shorted to enable the Bank 2 Analog Bus relays to close. The optional 34923T-002 (for 1-wire) shorts these pins for you. This feature protects inadvertent routing of high voltages from the Analog Buses to the D-sub connector of the module.

34923T-002 Terminal Block for One-Wire Mode

This terminal block with screw-type connections is labeled with the model number and the abbreviated module name. In addition, space is available on the label for you to write the slot number

NOTE

All modules that connect to the internal DMM are interlock protected. This means that when an installed module is exposed (no terminal block or cable is connected), the Analog Bus relays are open and disconnected from the Analog Buses. See “[Safety Interlock](#)” on page 11 for further information.

NOTE

If you are using an Keysight terminal block to connect your DUT to this module be sure to use the 34923T-002 terminal block that corresponds to the 1-wire configuration mode. An error will not be generated if you have installed a terminal block that doesn't match the present module configuration.

The *34980A Product Reference* CD (shipped with the instrument) contains a 34923T (1-wire mode) Wiring Log for you to document your wiring configuration for this module. You can open the wiring log file in Microsoft® Excel® or Adobe® Acrobat® format.

Low Frequency Multiplexer Modules

Wire Size:
 20 AWG Typical
 18 AWG Max

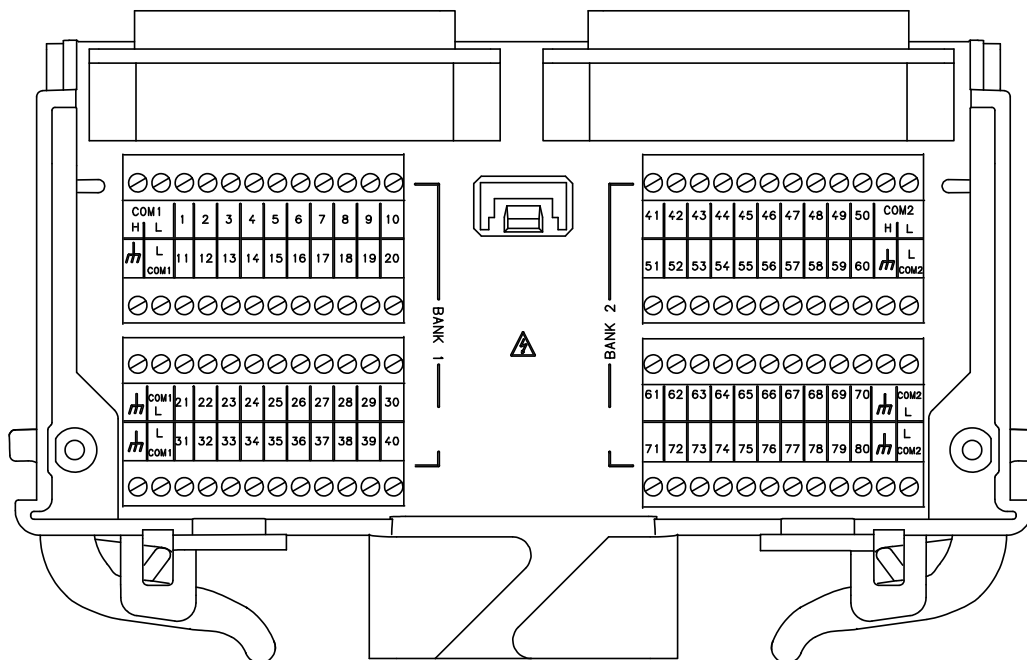

34924A 70-Channel Reed Multiplexer

The high-density 34924A 70-Channel Reed Multiplexer (70-Ch Reed MUX) is divided into two banks with 35 non-latching reed switches (channels 1-35 and 36-70) in each. This module also contains eight armature Analog Bus relays (channels 911-914 and 921-924), four on each bank that can connect the bank relays to the system Analog Buses. Through ABus1 and ABus2 you can connect any of the channels to the system DMM for voltage or resistance measurements. See the simplified schematic on [page 42](#).

Using program commands or the mainframe front panel, you can control each of the channel switches individually, and thus configure the 34924A in any of these modes:

- two independent 35-channel 2-wire MUXes. This configuration requires neither using external wiring nor connecting through the internal Analog Buses.
- one 70-channel, 2-wire MUX. You must use external wiring or connect through the internal Analog Buses for this configuration.
- one 35-channel 4-wire MUX. This configuration requires neither using external wiring nor connecting through the internal Analog Buses. For 4-wire resistance measurements, the instrument automatically pairs channel n on Bank 1 (source) with channel $n+35$ on Bank 2 (sense) to provide these connections. Four-wire controls occur only when doing 4-wire measurement operations through the internal DMM, such as `MEASure:FRESistance?` or scanning a channel previously configured as 4-wire.

In 2-wire mode, you can close no more than 20 channels simultaneously due to power dissipation. These 20 channels are split 10 to a bank. However, note that Analog Bus relays count half as much as channel relays in that total. For example, with one Analog Bus relay closed, you can close up to a maximum of 19 channel relays. If you try to close more than the allowed number of channels, you will receive an error message.

In all modes, this module has capability to scan as many as 500 channels/second using the internal DMM. With the automatic “break-before-make” connection operation, you are assured that no two signals are connected to each other during a scan.

CAUTION

Because user-attached reactive loads and backplane parasitic capacitance may result in high in-rush currents, 100 Ω in-rush resistors protect the reed relays from damage and performance degradation. Therefore, you must consider these resistors when you are designing a measurement. Refer to the simplified schematic on [page 42](#).

This module is interlock protected, which means whenever the D-sub connector end of the modules is exposed, the Analog Bus relays immediately open and disconnect from the Analog Bus. For more information, see “[Safety Interlock](#)” on page 11.

Lifetime of relays is severely degraded as current or voltage goes up. If higher voltage is being switched, limits on source current are recommended.

When the power is off, all channel and Analog Bus relays open.

34924A Simplified Schematic

This drawing shows two independent 35-channel 2-wire MUXes.

NOTE

The three-digit number assigned to each switch represents the channel number.

Bank relays: Reed non-latching; Analog Bus relays: Armature non-latching

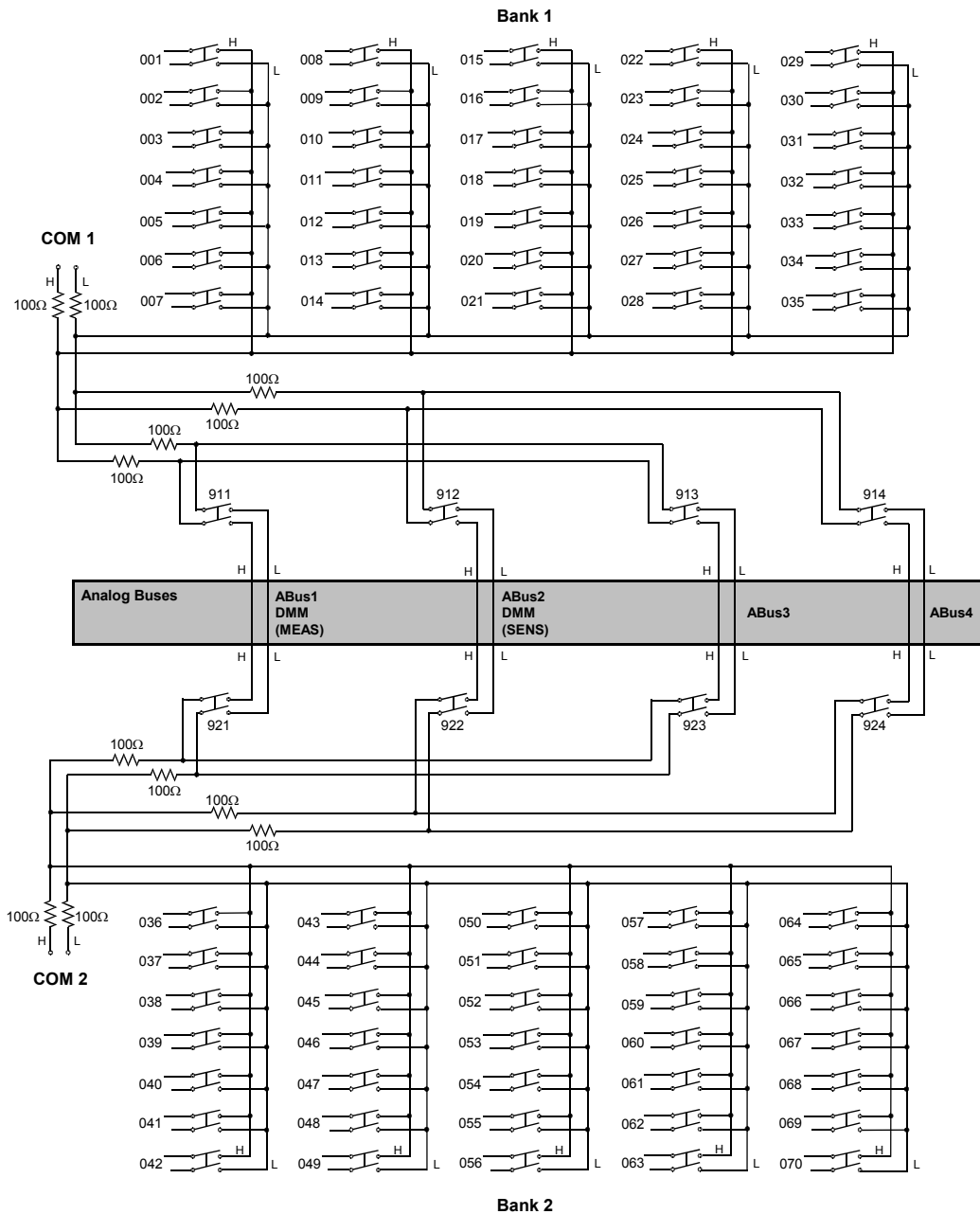

34924A D-Sub Connectors

Bank 1

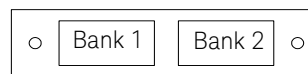

For orientation, the D-sub connector end of the module is facing you.

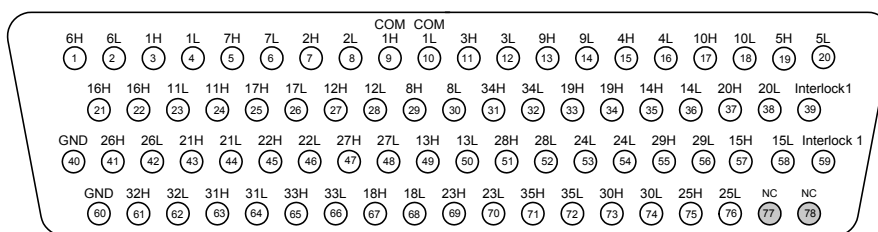

78-Pin D-Sub Male Connector

Desc	Pin	Desc	Pin	Desc	Pin	Desc	Pin	Desc	Pin	Desc	Pin
1H	3	8H	29	15H	57	22H	45	29H	55	COM1 H	9
1L	4	8L	30	15L	58	22L	46	29L	56	COM1 L	10
2H	7	9H	13	16H	21	23H	69	30H	73	Interlock 1	39
2L	8	9L	14	16L	22	23L	70	30L	74	Interlock 1	59
3H	11	10H	17	17H	25	24H	53	31H	63	GND	40
3L	12	10L	18	17L	26	24L	54	31L	64	GND	60
4H	15	11H	23	18H	67	25H	75	32H	61	No Connect	77
4L	16	11L	24	18L	68	25L	76	32L	62	No Connect	78
5H	19	12H	27	19H	33	26H	41	33H	65		
5L	20	12L	28	19L	34	26L	42	33L	66		
6H	1	13H	49	20H	37	27H	47	34H	31		
6L	2	13L	50	20L	38	27L	48	34L	32		
7H	5	14H	35	21H	43	28H	51	35H	71		
7L	6	14L	36	21L	44	28L	52	35L	72		

WARNING

As a safety feature, interlock 1 pins (39 and 59) on Bank 1 must be shorted to enable the Bank 1 Analog Bus relays to close. The optional 34924T terminal blocks short these pins for you. This feature protects inadvertent routing of high voltages from the Analog Buses to the D-sub connector of the module.

Bank 2

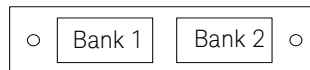

For orientation, the D-sub connector end of the module is facing you.

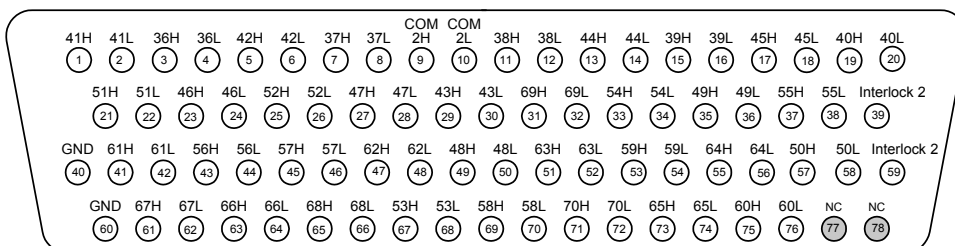

78-Pin D-Sub Male Connector

Desc	Pin	Desc	Pin	Desc	Pin	Desc	Pin	Desc	Pin	Desc	Pin
36H	3	43H	29	50H	57	57H	45	64H	55	COM2 H	9
36L	4	43L	30	50L	58	57L	46	64L	56	COM2 L	10
37H	7	44H	13	51H	21	58H	69	65H	73	Interlock 2	39
37L	8	44L	14	51L	22	58L	70	65L	74	Interlock 2	59
38H	11	45H	17	52H	25	59H	53	66H	63	GND	40
38L	12	45L	18	52L	26	59L	54	66L	64	GND	60
39H	15	46H	23	53H	67	60H	75	67H	61	No Connect	77
39L	16	46L	24	53L	68	60L	76	67L	62	No Connect	78
40H	19	47H	27	54H	33	61H	41	68H	65		
40L	20	47L	28	54L	34	61L	42	68L	66		
41H	1	48H	49	55H	37	62H	47	69H	31		
41L	2	48L	50	55L	38	62L	48	69L	32		
42H	5	49H	35	56H	43	63H	51	70H	71		
42L	6	49L	36	56L	44	63L	52	70L	72		

WARNING

As a safety feature, interlock 2 pins (39 and 59) on Bank 2 must be shorted to enable the Bank 2 Analog Bus relays to close. The optional 34924T terminal blocks short these pins for you. This feature protects inadvertent routing of high voltages from the Analog Buses to the D-sub connector of the module.

34924T Terminal Blocks

Two terminal blocks are available to facilitate wiring connections to the 34924A module:

34924T-001 (Option 001)	Terminal block with solder connectors
34924T-002 (Option 002)	Terminal block with screw connectors

The 34980A *Product Reference* CD (shipped with the instrument) contains a 34924T Wiring Log for you to document your wiring configuration for this module. You can open the wiring log file in Microsoft® Excel® or Adobe® Acrobat® format.

NOTE

All modules that connect to the internal DMM are interlock protected. This means that when an installed module is exposed (no terminal block or cable is connected), the Analog Bus relays are open and disconnected from the Analog Buses. See “[Safety Interlock](#)” on page 11 for further information.

34924T-001 Terminal Block

This terminal block with solder-type connections is labeled with the model number and the abbreviated module name. In addition, space is available on the label for you to write the slot number.

Wire Size:
22 AWG
Typical

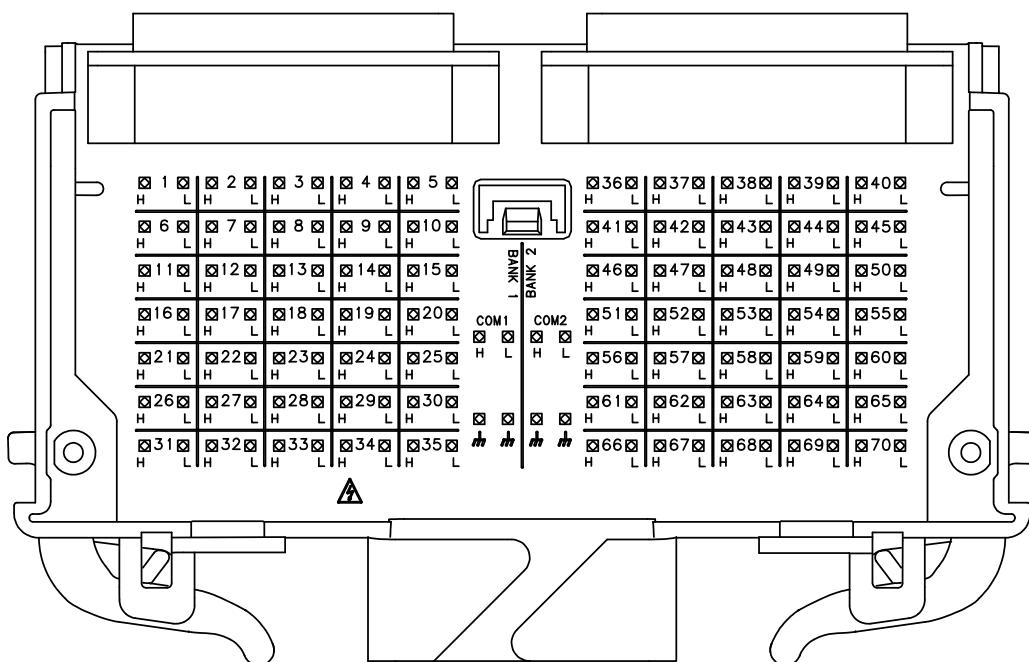

34924T-002 Terminal Block

This terminal block with screw-type connections is labeled with the model number and the abbreviated module name. In addition, space is available on the label for you to write the slot number.

Wire Size:
20 AWG
Typical

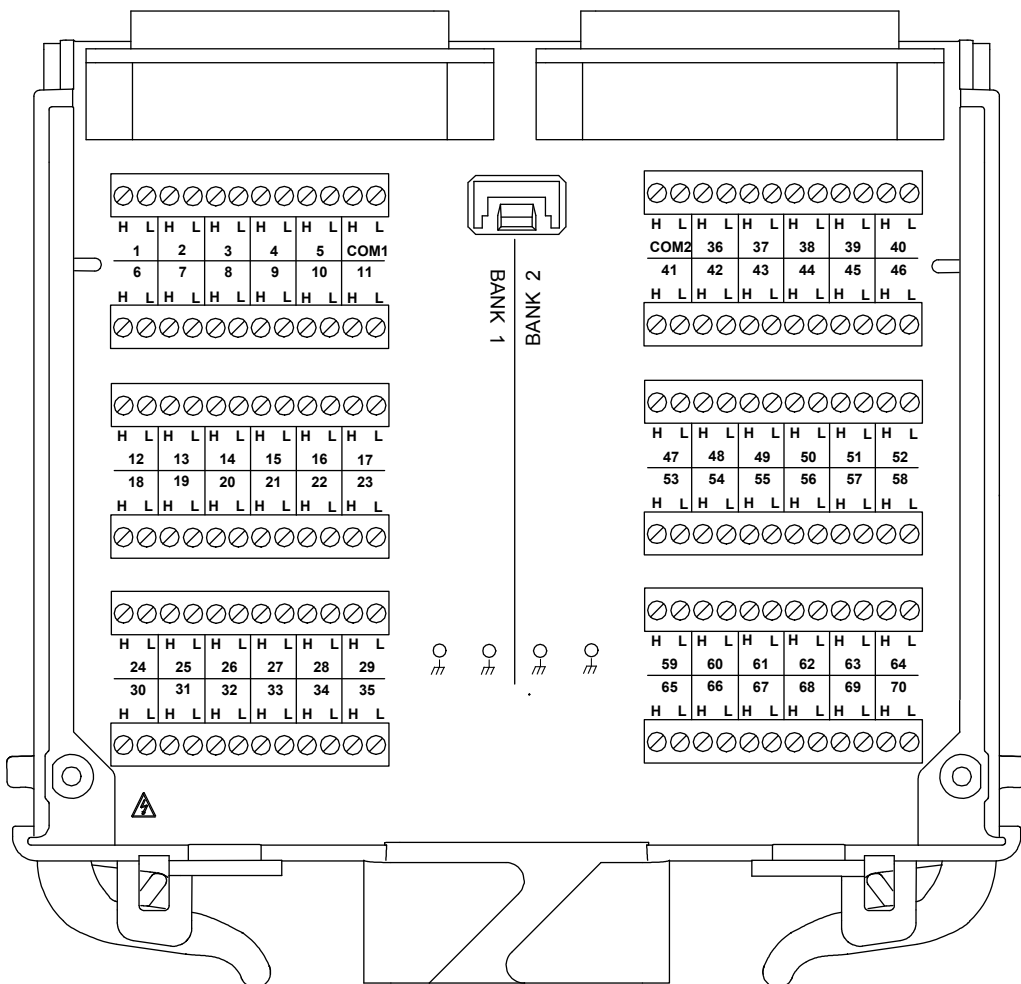

34925A 40/80-Channel Optically-Isolated FET Multiplexer

The 34925A 40/80-Channel Optically-Isolated FET Multiplexer (40/80-Ch FET MUX) module is a high-speed and high-density FET MUX for high throughput production test. This module is divided into two equal banks of non-latching FET switches. This module also contains four armature Analog Bus relays. Through ABus1 and ABus2 you can connect any of the channels to the internal DMM for voltage or resistance measurements. When the power is off, all channel and Analog Bus relays open.

Using program commands or the mainframe front panel, you can control each of the FET channel switches individually, and configure this module for differential (2-wire or 4-wire) or single-ended (1-wire) mode.

Refer to the simplified schematics on [page 50](#) and [page 54](#).

If you are using an Keysight 34925T-00x terminal block to connect your DUT to this module, be sure to use the terminal block that corresponds to your module configuration mode (Refer to the terminal block drawings on [page 53](#) and [page 57](#)):

34925T-001 (Option 001)	Terminal block for differential (two- or four-wire) mode
34925T-002 (Option 002)	Terminal block for single-ended (1-wire) mode

You can confirm the mode in which your module is configured by using the `SYSTEM:CTYPE? <slot number>` program command. This command returns the identity of the plug-in module in the specified slot.

NOTE

Whenever you change from 2- or 4-wire mode to 1-wire mode, or the reverse, you must cycle power on the 34980A for the configuration to take effect.

Two-Wire Mode

- two independent 20-channel 2-wire MUXes. This configuration requires neither using external wiring nor connecting through the internal Analog Bus relays.
- one 40-channel, 2-wire MUX. You must use external wiring or connect through the Analog Bus relays to for this configuration.

Four-Wire Mode

- You may configure the 34925A as a single 20-channel 4-wire MUX. This configuration requires using neither external wiring nor connecting through the internal Analog Buses. For 4-wire resistance measurements, the instrument automatically pairs channel n on Bank 1 (source) with channel $n+20$ on Bank 2 (sense) to provide these connections. Four-wire controls occur only when doing 4-wire measurement operations through the internal DMM, such as `MEASure:FRESistance?` or scanning a channel previously configured as 4-wire.

One-Wire Mode

- two independent 40-channel 1-wire MUXes. This configuration requires neither using external wiring nor connecting through the Analog Bus relays.
- one 80-channel 1-wire MUX. You must use external wiring or connect through the Analog Bus relays for this configuration.

NOTE

Because all bank relays supply only HI signals, you can apply a LOW signal through COM1 L or COM2 L when you are making 2-wire resistance measurements in 1-wire mode.

Interlock Protection

This module is interlock protected, which means whenever the D-sub connector end of the modules is exposed, the Analog Bus relays immediately open and disconnect from the Analog Buses. For more information, see “[Safety Interlock](#)” on page 11.

Overvoltage Protection

This module also features high voltage detection (< 100 V) and current limiting circuitry to protect the FET relays. This circuitry senses current flows from input overvoltages. These overvoltages may come from either the MUX input or from the Analog Buses. In addition, each channel is also protected from input overvoltages with a resistor.

When overvoltage is detected, all relays (Analog Bus and FET) are opened. While in the overvoltage state, any attempts to close any Analog Bus or FET switch, results in an error status response from the module.

Once in the overvoltage state, you must restore normal module operation with one of these actions:

- using the `SYSTEM:CPON <slot>` command. This affects only the module specified.

- using the *RST command. This command resets the mainframe and all installed modules to the Factory configuration. This affects all installed modules.
- cycling system power. This affects all installed modules.

If the overvoltage situation is not resolved, clearing the overvoltage will result in a new overvoltage event occurring immediately.

Further FET protection is assured only as one channel in each bank is closed at any time. Thus this module will operate as only a 1:N MUX module. For more information about FET channel closures, refer to [page 12](#).

34925A Simplified Schematic for Two- or Four-Wire Mode

This drawing shows two independent 20-channel 2-wire MUXes.
 To change configuration modes, use the **SYSTEM:MODuLe:WIRE:MODE** command

NOTE The three-digit number assigned to each switch represents the channel number.
 Bank relays: FET non-latching; Analog Bus relays: Armature non-latching

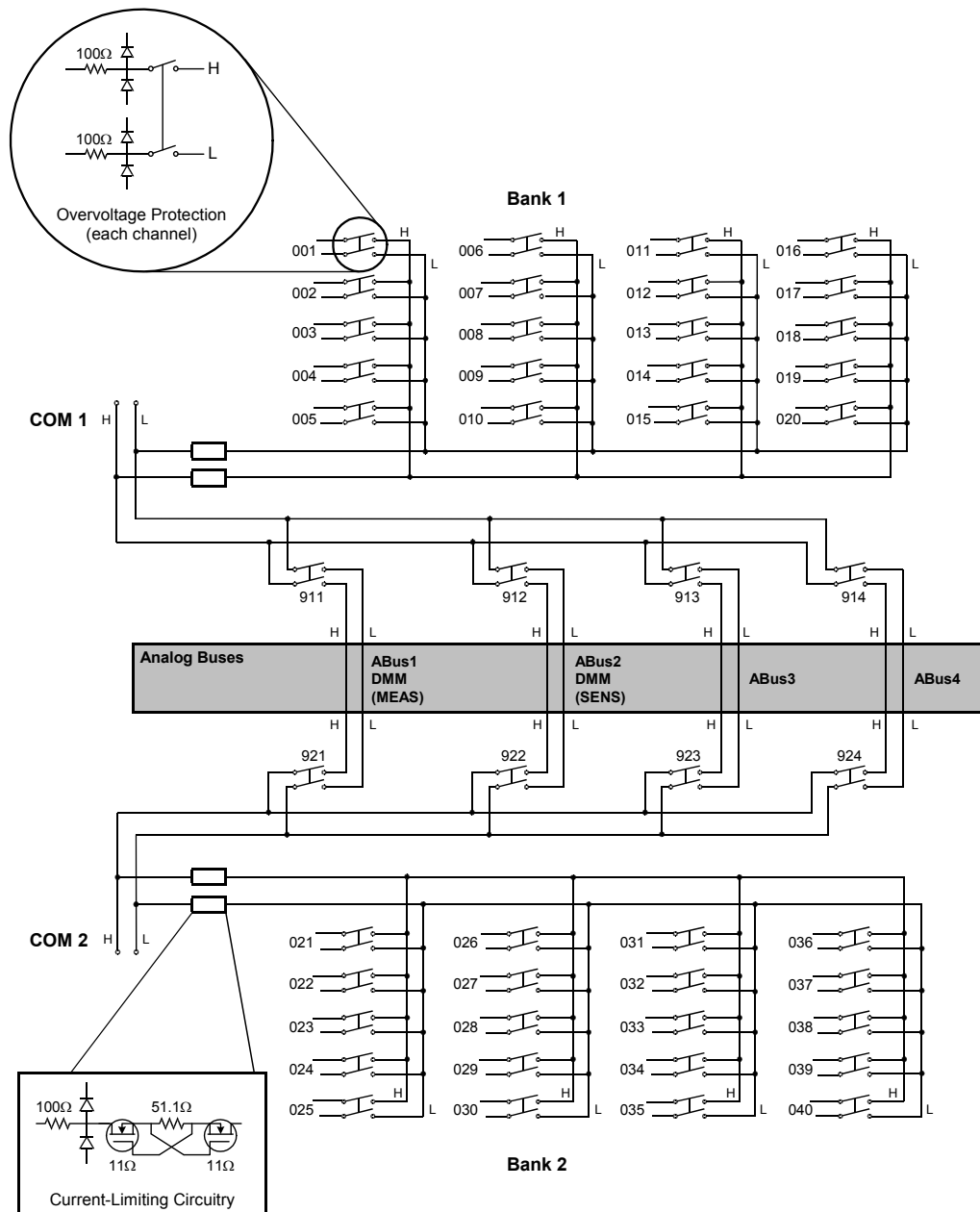

34925A D-Sub Connectors for Two- or Four-Wire Mode

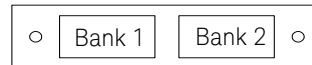

Bank 1

For orientation, the D-sub connector end is facing you.

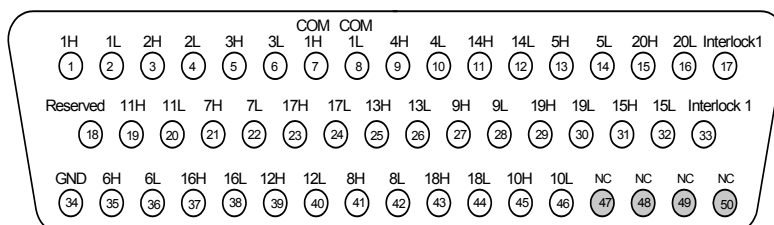

50-Pin D-Sub Male Connector

Desc	Pin	Desc	Pin	Desc	Pin	Desc	Pin	Descr	Pin
1H	1	6H	35	11H	19	16H	37	COM1 H	7
1L	2	6L	36	11L	20	16L	38	COM1 L	8
2H	3	7H	21	12H	39	17H	23	Interlock1	17
2L	4	7L	22	12L	40	17L	24	Interlock 1	33
3H	5	8H	41	13H	25	18H	43	Reserved	18
3L	6	8L	42	13L	26	18L	44	GND	34
4H	9	9H	27	14H	11	19H	29	No Connect	47
4L	10	9L	28	14L	12	19L	30	No Connect	48
5H	13	10H	45	15H	31	20H	15	No Connect	49
5L	14	10L	46	15L	32	20L	16	No Connect	50

WARNING

As a safety feature, interlock 1 pins (17 and 33) on Bank 1 must be shorted to enable the Bank 1 Analog Bus relays to close. The optional 34925T-001 (for 2-wire) terminal block shorts these pins for you. This feature protects inadvertent routing of high voltages from the Analog Bus to the D-sub connector of the module.

Bank 2

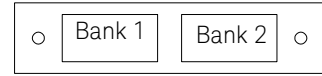

For orientation, the D-sub connector end of the module is facing you.

50-Pin D-Sub Male Connector

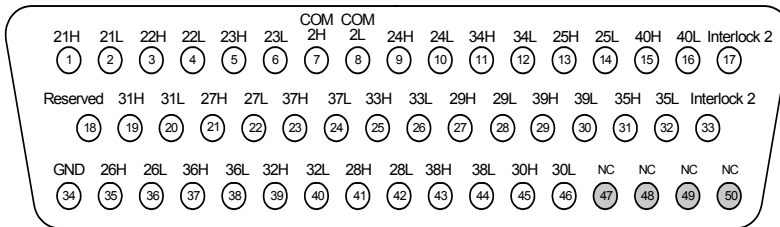

Desc	Pin	Desc	Pin	Desc	Pin	Desc	Pin	Desc	Pin
21H	1	26H	35	31H	19	36H	37	COM2 H	7
21L	2	26L	36	31L	20	36L	38	COM2 L	8
22H	3	27H	21	32H	39	37H	23	Interlock 2	17
22L	4	27L	22	32L	40	37L	24	Interlock 2	33
23H	5	28H	41	33H	25	38H	43	Reserved	18
23L	6	28L	42	33L	26	38L	44	GND	34
24H	9	29H	27	34H	11	39H	29	No Connect	47
24L	10	29L	28	34L	12	39L	30	No Connect	48
25H	13	30H	45	35H	31	40H	15	No Connect	49
25L	14	30L	46	35L	32	40L	16	No Connect	50

WARNING

As a safety feature, interlock 2 pins (17 and 33) on Bank 2 must be shorted to enable the Bank 2 Analog Bus relays to close. The optional 34925T-001 (for 2-wire) terminal block shorts these pins for you. This feature protects inadvertent routing of high voltages from the Analog Buses to the D-sub connector of the module.

34925T-001 Terminal Block for Two-Wire or Four-Wire Mode

This terminal block with screw-type connections is labeled with the model number and the abbreviated module name. In addition, space is available on the label for you to write the slot number.

NOTE

- All modules that connect to the internal DMM are interlock protected. This means that when an installed module is exposed (no terminal block or cable is connected), the Analog Bus relays are open and disconnected from the Analog Buses. See “**Safety Interlock**” on page 11 for further information.
- If you are using an Keysight terminal block to connect your DUT to this module be sure to use the 34925T-001 terminal block that corresponds to the 2- or 4-wire configuration mode. An error will not be generated if you have installed a terminal block that doesn't match the present module configuration.

The 34980A *Product Reference* CD (shipped with the instrument) contains a 34925T (2-wire mode) Wiring Log for you to document your wiring configuration for this module. You can open the wiring log file in Microsoft® Excel® or Adobe® Acrobat® format.

Wire Size:
20 AWG Typical
18 AWG Max

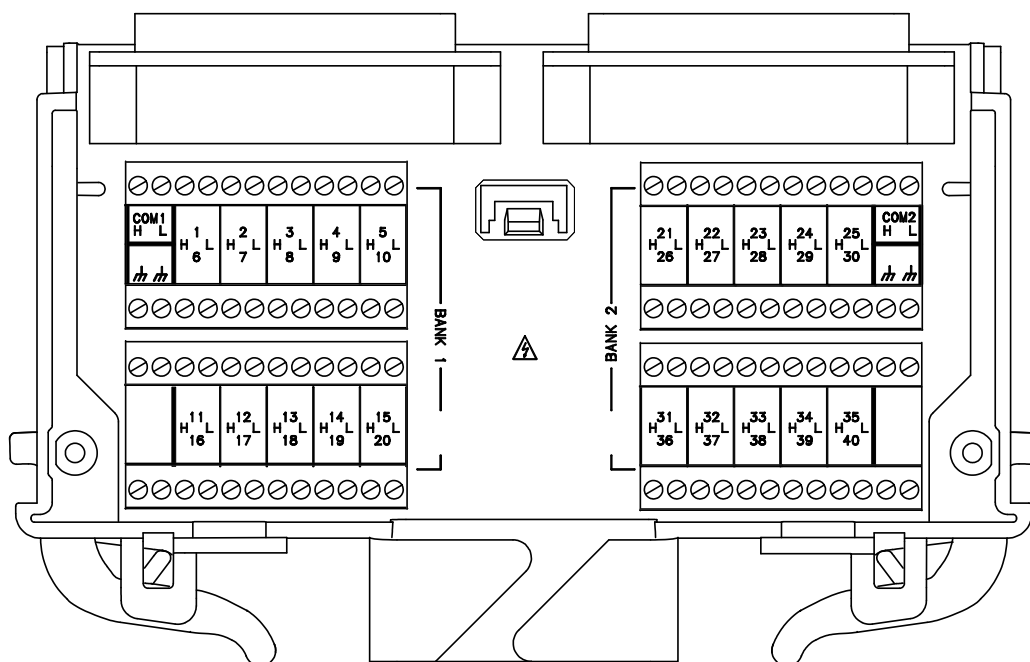

34925A Simplified Schematic for One-Wire Mode

This drawing shows two independent 40-channel, 1-wire MUXes.
 To change configuration modes, use the **SYSTEM:MODUle:WIRE:MODE** command

NOTE

The three-digit number assigned to each switch represents the channel number.

Bank relays: FET non-latching; Analog Bus relays: Armature non-latching

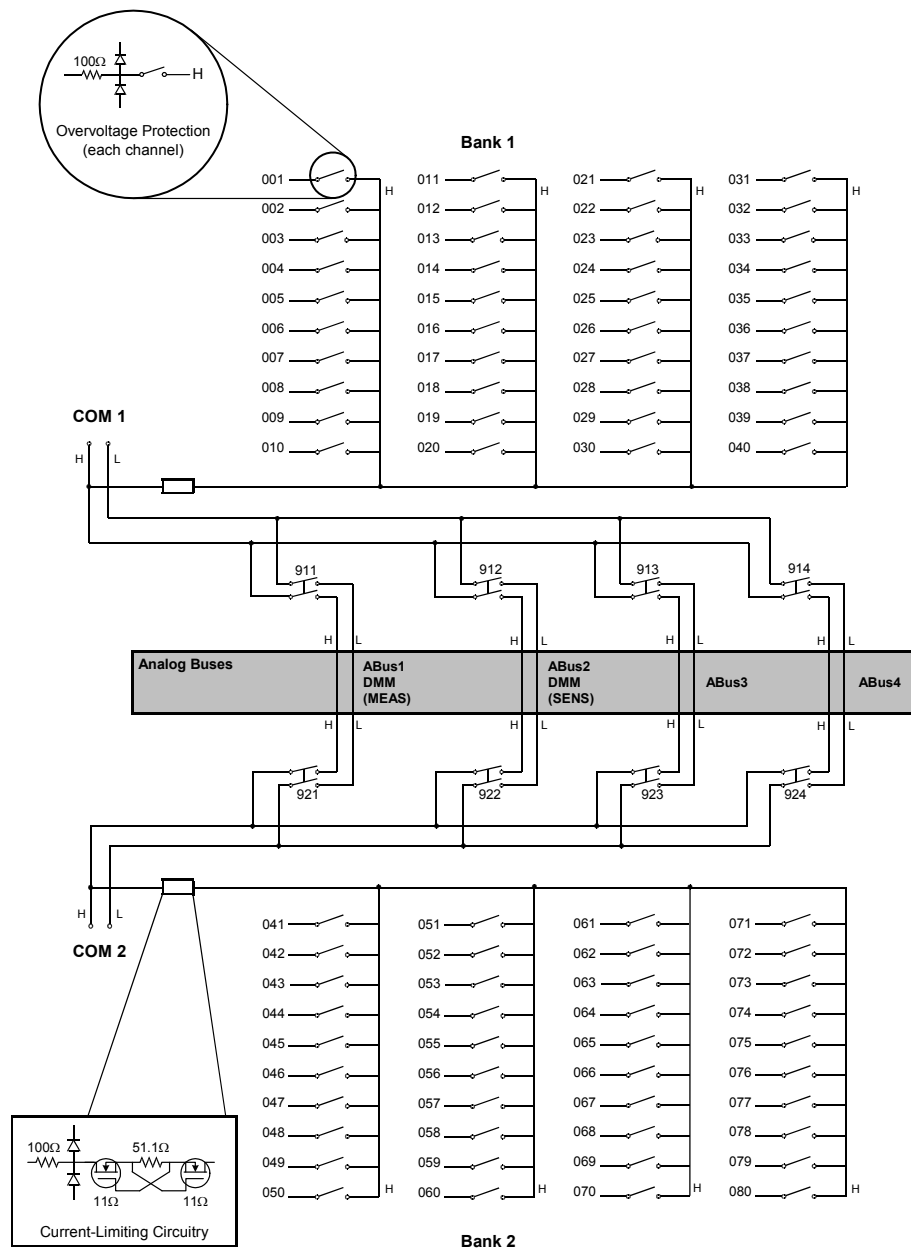

34925A D-Sub Connectors for One-Wired Mode

Bank 1

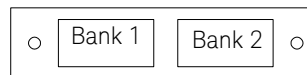

For orientation, the D-sub connector end of the module is facing you.

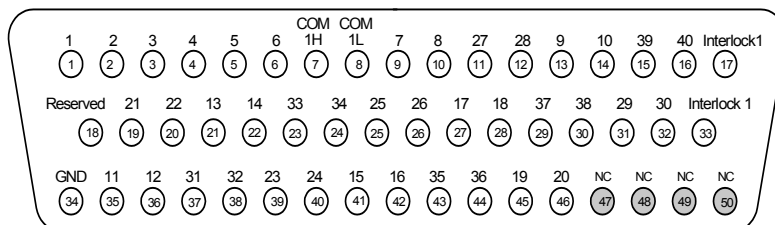

50-Pin D-Sub Male Connector

Desc	Pin	Desc	Pin	Desc	Pin	Desc	Pin	Desc	Pin
1	1	11	35	21	19	31	37	COM1 H	7
2	2	12	36	22	20	32	38	COM1 L	8
3	3	13	21	23	39	33	23	Interlock 1	17
4	4	14	22	24	40	34	24	Interlock 1	33
5	5	15	41	25	25	35	43	Reserved	18
6	6	16	42	26	26	36	44	GND	34
7	9	17	27	27	11	37	29	No Connect	47
8	10	18	28	28	12	38	30	No Connect	48
9	13	19	45	29	31	39	15	No Connect	49
10	14	20	46	30	32	40	16	No Connect	50

WARNING

As a safety feature, interlock 1 pins (17 and 33) on Bank 1 must be shorted to enable the Bank 1 Analog Bus relays to close. The optional 34925T-002 (for 1-wire) terminal block shorts these pins for you. This feature protects inadvertent routing of high voltages from the Analog Bus to the D-sub connector of the module.

Bank 2

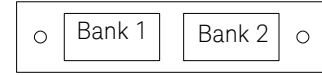

For orientation, the D-sub connector end of the module is facing you.

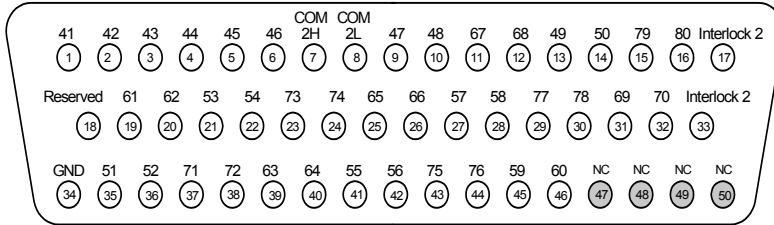

50-Pin D-Sub Male Connector

Desc	Pin	Desc	Pin	Desc	Pin	Desc	Pin	Desc	Pin
41	1	51	35	61	19	71	37	COM2 H	7
42	2	52	36	62	20	72	38	COM2 L	8
43	3	53	21	63	39	73	23	Interlock 2	17
44	4	54	22	64	40	74	24	Interlock 2	33
45	5	55	41	65	25	75	43	Reserved	18
46	6	56	42	66	26	76	44	GND	34
47	9	57	27	67	11	77	29	No Connect	47
48	10	58	28	68	12	78	30	No Connect	48
49	13	59	45	69	31	79	15	No Connect	49
50	14	60	46	70	32	80	16	No Connect	50

WARNING

As a safety feature, interlock 2 pins (17 and 33) on Bank 2 must be shorted to enable the Bank 2 Analog Bus relays to close. The optional 34925T-002 (for 1-wire) terminal block shorts these pins for you. This feature protects inadvertent routing of high voltages from the Analog Buses to the module.

34925T-002 Terminal Block for One-Wire Mode

This terminal block with screw-type connections is labeled with the model number and the abbreviated module name. In addition, space is available on the label for you to write the slot number.

NOTE

All modules that connect to the internal DMM are interlock protected. This means that when an installed module is exposed (no terminal block or cable is connected), the Analog Bus relays are open and disconnected from the Analog Buses. See “[Safety Interlock](#)” on page 11 for further information.

NOTE

If you are using an Keysight terminal block to connect your DUT to this module be sure to use the 34925T-002 terminal block that corresponds to the 1-wire configuration mode. An error will not be generated if you have installed a terminal block that doesn't match the present module configuration.

The 34980A *Product Reference* CD (shipped with the instrument) contains a 34925T (1-wire mode) Wiring Log for you to document your wiring configuration for this module. You can open the wiring log file in Microsoft® Excel® or Adobe® Acrobat® format.

Wire Size:
20 AWG Typical
18 AWG Max

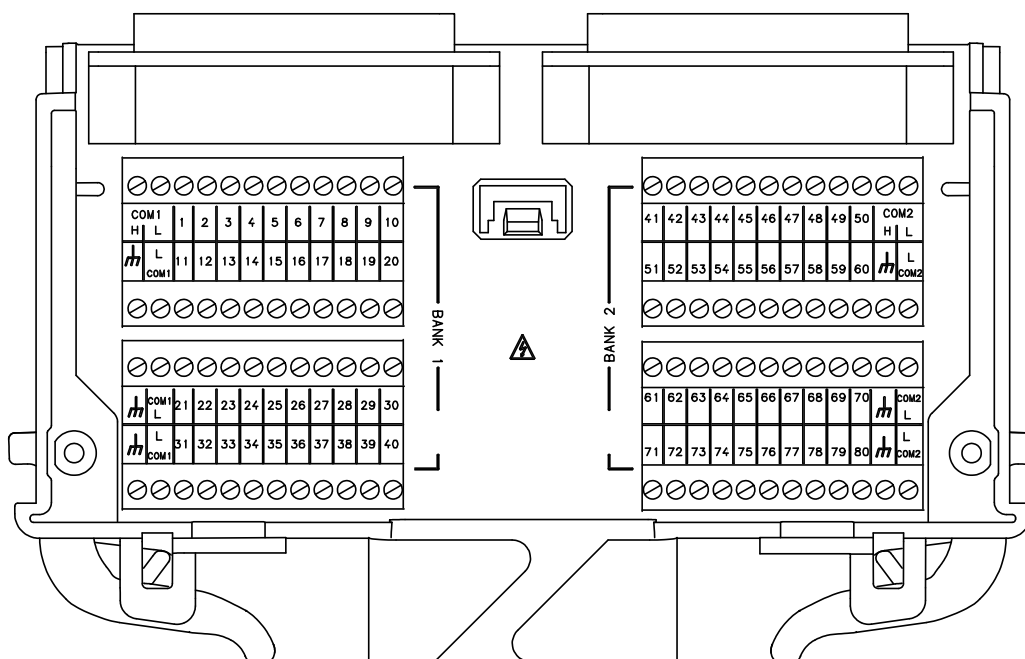

Index

Numerics

34921A

- connector pinouts, 18
- description, 15
- external reference, 20
- programming examples, 12
- simplified schematic, 17
- temperature sensor, 20
- terminal block, 20
- valid measurement functions, 10
- wiring log, 20

34922A

- connector pinouts, 24
- description, 22
- programming examples, 12
- simplified schematic, 23
- terminal blocks, 26, 27
- valid measurement functions, 10
- wiring log, 26

34923A

- connector pinouts, 32, 36
- description, 28
- programming examples, 12
- simplified schematic, 31, 35
- terminal blocks, 34, 38
- valid measurement functions, 10
- wiring log, 34, 38

34924A

- connector pinouts, 43
- description, 40
- programming examples, 12
- simplified schematic, 42
- terminal blocks, 45, 46
- valid measurement functions, 10
- wiring log, 45

34925A

- connector pinouts, 51, 55
- description, 47
- overload protection, 48
- programming examples, 12
- simplified schematic, 50, 54
- terminal blocks, 53, 57

- valid measurement functions, 10
- wiring log, 53, 57

C

connector pinouts

- 34921A, 18
- 34922A, 24
- 34923A, 32, 36
- 34924A, 43
- 34925A, 51, 55

D

D-sub pinouts

- 34921A, 18
- 34922A, 24
- 34923A, 32, 36
- 34924A, 43
- 34925A, 51, 55

E

- external reference, 20

F

- FET protection, 48

I

- isothermal block, 20

O

- operating considerations, 11
- overload protection, 48
- overvoltage protection, 48

P

pinouts

- 34921A, 18
- 34922A, 24
- 34923A, 32, 36
- 34924A, 43
- 34925A, 51, 55

T

- temperature sensor, 20

terminal block

- 34921T, 21
- 34922T Option 001, 26
- 34922T Option 002, 27
- 34923T Option 001, 34
- 34923T Option 002, 38
- 34924T Option 001, 45
- 34924T Option 002, 46
- 34925T Option 001, 53
- 34925T Option 002, 57



This information is subject to change
without notice

© Keysight Technologies 2016

Edition 2 January 2016

Published in USA



34980-90021

www.keysight.com