

INFCH

INFINITY[®] C Thermistor Indicator/Controller

Operator's Manual



NEWPORT Electronics, Inc.

<http://www.newportUS.com/manuals>





Additional products from

NEWPORT Electronics, Inc.

Counters	Rate Meters
Frequency Meters	Timers
PID Controllers	Totalizers
Clock/Timers	Strain Gauge Meters
Printers	Voltmeters
Process Meters	Multimeters
On/Off	Soldering Iron
Controllers	Testers
Recorders	pH pens
Relative	pH Controllers
Humidity	pH Electrodes
Transmitters	RTDs
Thermocouples	Thermowells
Thermistors	Flow Sensors
Wire	

For Immediate Assistance

In the U.S.A. and Canada: 1-800-NEWPORT[®]

In Mexico: (95) 800-NEWPORTSM

Or call your local NEWPORT Office.

NEWPORTnetSM On-Line Service

<http://www.newportUS.com>

Internet e-mail

info@newportUS.com

It is the policy of NEWPORT to comply with all worldwide safety and EMC/EMI regulations that apply. NEWPORT is constantly pursuing certification of its products to the European New Approach Directives. NEWPORT will add the CE mark to every appropriate device upon certification.

The information contained in this document is believed to be correct but NEWPORT Electronics, Inc. accepts no liability for any errors it contains, and reserves the right to alter specifications without notice.

WARNING: These products are not designed for use in, and should not be used for, patient connected applications.

PATENT NOTICE: The "Meter Case Bezel Design" is a trademark of NEWPORT Electronics, Inc., registered in the U.S.

PATENT NOTICE: This product is covered by one or more of the following patents: U.S. Pat. No. Des. 336,895; 5,274,577 / Canada 2052599; 2052600 / Italy 1249456; 1250938 / France Brevet No. 91 12756 / Spain 2039150; 2048066 / UK Patent No. GB2 249 837; GB2 248 954 / Germany DE 41 34398 C2. Other International Patents Pending.



This device is marked with the international caution symbol. It is important to read the Setup Guide before installing or commissioning this device as it contains important information relating to safety and EMC.

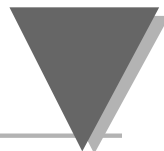

MANUAL OBJECTIVE

This manual shows you how to set up and use the thermistor indicator/controller.

Table A-1. Sections of the Manual

If you want to read about:	Sec#	Refer to section
Unpacking; safety considerations	1	Introduction
Meter description and features	2	About the Meter
Main board power jumpers; panel mounting, sensor input, main power and analog output option and dual relay output option	3	Getting Started
Input type; decimal point position; reading configuration: setpoint configurations; setpoint deadbands, output configuration (analog output option); analog output option scaling, lock out configuration	4	Configuring the Meter
Selecting Setpoint Values	5	Selecting Setpoint Values
Display messages	6	Display Messages
Meter menu/sub-menu messages	7	Menu Configuration Displays
Setpoint configuration messages	8	Setpoint Configuration Displays
Specifications	9	Specifications
Factory Defaults Setup as Shipped	10	Factory Preset Values

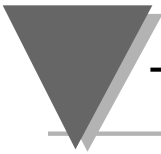

Table of Contents

Table of Contents

Section		Page
SEC 1	INTRODUCTION	1
	1.1 Unpacking	1
	1.2 Safety Considerations	2
SEC 2	ABOUT THE METER	3
	2.1 Description	3
	2.2 Features	3
	2.3 Available Accessories	4
	2.4 Front of the Meter	5
	2.5 Front-Panel Button Lock Out	8
	2.6 Back of the Meter	9
	2.7 Disassembly	11
SEC 3	GETTING STARTED	12
	3.1 Rating/Product Label	12
	3.2 Main Board Power Jumpers	12
	3.3 Main Board Jumpers	14
	3.4 Panel Mounting	15
	3.5 Connecting Sensor Input	16
	3.6 Connecting Main Power	17
	3.7 Connecting Analog and Relay Output Options	18
SEC 4	CONFIGURING THE METER	20
	4.1 Selecting the Input Type	20
	4.2 Selecting a Decimal Point Position	21
	4.3 Using Reading Configuration	21
	4.4 Using Setpoint 1 Configurations	22
	4.4.1 Setting Setpoint 1's Active Band	22
	4.4.2 Selecting if Setpoint 1 is Latched or Unlatched	23
	4.5 Using Setpoint 2 Configurations	23
	4.5.1 Setting Setpoint 2's Active Band	23
	4.5.2 Selecting if Setpoint 2 is Latched or Unlatched	24

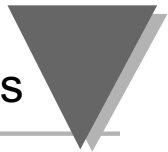

Table of Contents

Section		Page
4.6	Setting the Setpoint 1 Deadband24
4.7	Setting the Setpoint 2 Deadband26
4.8	Using Output Configuration26
4.8.1	Enabling or Disabling the Analog Output Option26
4.8.2	Selecting the Analog Output Option as Current or Voltage27
4.9	Using Output Scale and Offset28
4.9.1	Example for Output Scale and Offset30
4.10	Correcting Thermistor Temperature Offset Error32
SEC 5	SELECTING SETPOINT VALUES35
SEC 6	DISPLAY MESSAGES36
SEC 7	MENU CONFIGURATION DISPLAYS37
SEC 8	SETPOINT CONFIGURATION DISPLAYS40
SEC 9	SPECIFICATIONS41
SEC 10	FACTORY PRESET VALUES45
CE APPROVAL SECTION46

Notes, Warnings and Cautions

NOTES, WARNINGS and CAUTIONS

Information that is especially important to note is identified by three labels:

- **NOTE**
- **WARNING**
- **CAUTION**
- **IMPORTANT**

 **Note**

NOTE: provides you with information that is important to successfully setup and use the Programmable Digital Meter.



CAUTION or WARNING: tells you about the risk of electric shock.



CAUTION, WARNING or IMPORTANT: tells you of circumstances or practices that can effect the meter's functionality and must refer to accompanying documents.

SECTION 1. INTRODUCTION

1.1 UNPACKING

Remove the Packing List and verify that all equipment has been received. If there are any questions about the shipment, use the phone number for the Customer Service Department nearest you.

Upon receipt of shipment, inspect the container and equipment for any signs of damage. Take particular note of any evidence of rough handling in transit. Immediately report any damage to the shipping agent.

**Note**

The carrier will not honor any claims unless all shipping material is saved for their examination. After examining and removing contents, save packing material and carton in the event reshipment is necessary.

Verify that you receive the following items in the shipping box:

QTY	DESCRIPTION
1	Programmable Digital Meter indicator/controller with all applicable connectors attached.
1	Owner's Manual
1	Set Mounting brackets

Introduction

1.2 SAFETY CONSIDERATIONS



This device is marked with the **international caution symbol**. It is **important to read** this manual before installing or commissioning this device as it contains important information relating to **Safety and EMC** (Electromagnetic Compatibility).

This instrument is a **panel mount** device protected in accordance with EN 61010-1:2001, electrical safety requirements for electrical equipment for measurement, control and laboratory. Installation of this instrument should be done by qualified personnel. In order to ensure safe operation, the following instructions should be followed.



This instrument has **no power-on switch**. An external **switch or circuit-breaker** shall be included in the building installation as a disconnecting device. It shall be marked to indicate this function, and it shall be in close proximity to the equipment within easy reach of the operator. The switch or circuit-breaker shall not interrupt the Protective Conductor (Earth wire), and it shall meet the relevant requirements of IEC 947-1 and IEC 947-3 (International Electrotechnical Commission). The switch shall not be incorporated in the main supply cord.



Furthermore, to provide protection against **excessive energy** being drawn from the main supply in case of a fault in the equipment, an **overcurrent** protection device shall be installed.



Note

- Do not exceed voltage rating on the label located on the top of the instrument housing.
- Always disconnect power before changing signal and power connections.
- Do not use this instrument on a work bench without its case for safety reasons.
- Do not operate this instrument in flammable or explosive atmospheres.
- Do not expose this instrument to rain or moisture.
- Unit mounting should allow for adequate ventilation to ensure instrument does not exceed operating temperature rating.
- Use electrical wires with adequate size to handle mechanical strain and power requirements. Install without exposing bare wire outside the connector to minimize electrical shock hazards.

EMC Considerations

- Whenever EMC is an issue, always use shielded cables.
- Never run signal and power wires in the same conduit.
- Use signal wire connections with twisted-pair cables.
- Install Ferrite Bead(s) on signal wires close to the instrument if EMC problems persist.

Failure to follow all instructions and warnings may result in injury!

SECTION 2. ABOUT THE METER

2.1 DESCRIPTION

The thermistor indicator/controller converts the resistance of a thermistor probe to the equivalent temperature. The meter can be configured to use eight of the available thermistor probe types. There are four full digits to display temperature in Fahrenheit or Celsius. Maximum and minimum temperature values are retained and can be displayed or reset with the push of a front panel button. Two optional setpoints are available to control internal form C relays for process control. An optional analog output is available to send a scaled proportional voltage or current to a remote device. An internal mechanical lockout has been included to guard against unauthorized changes.

2.2 FEATURES

Standard features:

- * 4-digit 14-segment LED display
- * NEMA 4/Type 4 front bezel
- * $\pm 0.2^{\circ}\text{C}$ accuracy
- * $\pm 0.1^{\circ}\text{C}$ repeatability
- * 44004, 44005, 44006, 44007, 44008, 44016, 44018 and linear 700 thermistor types
- * Peak and valley detection and memory
- * Nonvolatile memory for configuration settings
- * Easy setup for proportional control
- * 115 or 230 Vac 50/60 Hz power supply
- * $0.01^{\circ}\text{C}/\text{F}$ resolution
- * Front panel push button lock out

Optional features (must be ordered at time of purchase):

- * Dual 5 amp, form C relay outputs
- * Scalable analog output

2.3 AVAILABLE ACCESSORIES

Table 2-1. Accessories and Add-ons

Add-On Options

FS	Special Calib/Config
SPC4	NEMA-4 Splash Proof Cover
SPC18	NEMA-4 Splash Proof Cover, NEW

Accessories

TP1A	Trimplate panel adaptor. Adapts DIN1A/DIN2A cases to larger panel cutouts
RP18	19-In. Rack Panel for one (1) 1/8 DIN instrument
RP28	19-In. Rack Panel for two (2) 1/8 DIN instrument
RP38	19-In. Rack Panel for three (3) 1/8 DIN instrument

2.4 FRONT OF THE METER

Figure 2-1 shows the front of the meter.

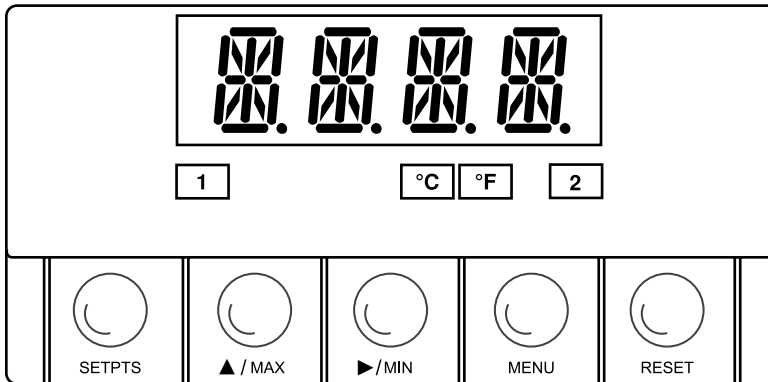

Figure 2-1. Front-Panel Illustration

METER DISPLAY:

Digital LED display - 1.9.9.9. or 9.9.9.9. 4-digit 14 segment, 0.54" high LED display with programmable decimal point.

These meter display windows light when appropriate (setpoints 1 and 2 light only if your meter has dual relay output capabilities):

- 1 Setpoint 1 status
- 2 Setpoint 2 status
- °C Celsius
- °F Fahrenheit

About The Meter

2.4 FRONT OF THE METER (Continued)

METER BUTTONS

SETPTS BUTTON - If your meter does not have dual relay output capabilities, pressing this button displays "RUN" and goes back to the run mode.

If your meter has dual relay output capabilities, this button will sequentially recall (in the run mode) the previous setpoint settings. As necessary, use the ▲ /MAX and ► /MIN buttons to alter these settings, then press the **SETPTS** button to store new values. Unless you press the **SETPTS**, ► /MIN, or ▲ /MAX button within 20 seconds, the meter will scroll to setpoint 2 and then to the run mode.

▲ /MAX BUTTON - In the run mode, this button will recall the **PEAK** reading since the last press of the **RESET** button.

In the configuration mode, press this button to change the value of the flashing digit shown on the display and/or toggle between menu choices, such as "**R.1=F**" or "**R.1=C**". When configuring your setpoint values, press the ▲ /MAX button to advance the flashing digit's value from 0 to 9 by 1.

► /MIN BUTTON - In the run mode, press this button to recall the valley reading since the last press of the **RESET** button.

In the configuration mode, press this button to scroll to the next digit.

2.4 FRONT OF THE METER (Continued)

MENU BUTTON - In the run mode, press the **MENU** button to terminate the current measuring process and enter you into the configuration mode.

In the configuration mode, press the **MENU** button to store changes in the nonvolatile memory and advance you to the next menu item.

RESET BUTTON - In the setpoint mode, press the **RESET** button to enter the run mode. The meter shows **"RUN"** and returns to the run mode.

In the configuration mode, press the **RESET** button to review the previous menu. Press the **RESET** button twice to perform a hard reset. The meter shows **"RST"**, followed by **"INIT"**, then enters the run mode.

In the peak mode, press the **RESET** button to reset peak value. The meter shows **"PK.RS"** and returns to the run mode.

In the valley mode, press the **RESET** button to reset valley value. The meter shows **"VL.RS"** and returns to the run mode.

In the run mode, if your meter does not have dual relay output capabilities, pressing the **RESET** button shows "RUN" and goes back to the run mode. If your meter has dual relay output capabilities, press the **RESET** button (in the run mode) to reset the latched setpoints. The meter shows **"SP.RS"** and returns to the run mode.

Note

*When in setpoint or configuration mode, if the meter shows 9999 or -1999 with all flashing digits, the value has overflowed. Press the **▲ IMAX** button to start a new value.*

2.5 FRONT-PANEL BUTTON LOCK OUT (For Security Purposes)

2.5.1 Jumper Lock Out

To lock all front-panel buttons, remove the S3-A jumper (refer to Figure 3-2).

To lock the **MENU** button only, verify that the S3-B jumper is removed, then install the S3-A and S3-E jumpers (refer to Table 3-1). If you press the **MENU** button, the meter shows "LOCK" and returns to the run mode.

2.5.2 Push Button Lock Out

To lock the **RESET**, **MENU** and **SETPTS** buttons, verify that the S3-A jumper is installed and the S3-E jumper is not installed, then follow these steps:

In the run mode -

1. Press and hold down **RESET** button. The meter shows "**SP.RS**" or "**RUN**". Do not release the **RESET** button.
2. Press the **MENU** button and hold **RESET** button down (3 - 5 seconds) until the meter shows "**LOCK**".
3. Release both buttons.

To unlock the **RESET**, **MENU** and **SETPTS** buttons, follow these steps:

1. Press and hold down **RESET** button. The meter shows "**LOCK**". Do not release the **RESET** button.
2. Press the **MENU** button and hold **RESET** button down (3 - 5 seconds) until the meter shows "**UN.LK**".
3. Release both buttons.

2.5 BACK OF THE METER

Figure 2-2 shows the label describing the connectors on the back of the meter. Table 2-2 on the following page gives a brief description of each connector at the back of the meter.

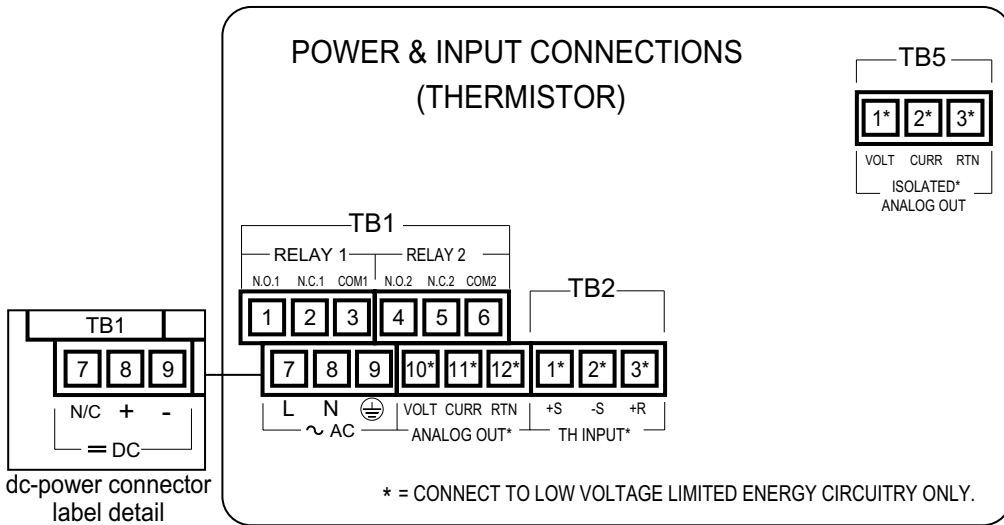

Figure 2-2. Connectors

2.6 BACK OF THE METER (Continued)

Table 2-2. Connector Description

Connector	Description
TB1-1	Setpoint 1: Normally open (N.O.1) connection.
TB1-2	Setpoint 1: Normally closed (N.C.1) connection.
TB1-3	Setpoint 1: Common 1 connection
TB1-4	Setpoint 2: Normally open (N.O.2) connection.
TB1-5	Setpoint 2: Normally closed (N.C.2) connection.
TB1-6	Setpoint 2: Common 2 connection
TB1-7	ac line connection (no connection on dc powered units)
TB1-8	ac neutral connection (+ Input on dc powered units)
TB1-9	ac ground (dc power return on dc powered units)
TB1-10	Analog 1 voltage output
TB1-11	Analog 2 current output
TB1-12	Analog 3 return
TB2-1	+S Thermistor input
TB2-2	-S Thermistor input
TB2-3	+R 3 rd input for Linear Thermistor
TB5-1	Isolated Analog Voltage Output
TB5-2	Isolated Analog Current Output
TB5-3	Isolated Analog Output Return

2.7 DISASSEMBLY

You may need to open up the meter for one of the following reasons:

- To check or change the 115 or 230 Vac power jumpers.
- To install or remove jumpers on the main board.

Note

Disconnect the power supply before proceeding.

To remove and access the main board, follow these steps:

- Disconnect the main power from the meter.
- Remove the back case cover.
- Lift the back of the main board upwards and let it slide out of the case.

SECTION 3. GETTING STARTED



Caution: The meter has no power-on switch, so it will be in operation as soon you apply power.

If you power off/on the meter, it displays “RST”, followed by a scrolling display of “THERMISTOR”, followed by “Vxx” (designating the version number, xx stands for the current version). Write down this version number as you will need if you telephone Customer Service.

3.1 RATING/PRODUCT LABEL

This label is located on top of the meter housing (refer to Figure 3-4).

3.2 MAIN BOARD POWER JUMPERS (Refer to Figure 3-1)



Important: If you want to change the Factory preset jumpers, do the following steps; otherwise go to section 3.3.

Note

Disconnect the power from the unit before proceeding.

1. Remove the main board from the case. Refer to Section 2.7.
2. Locate the solder jumpers W1, W2, and W3 (located near the edge of the main board alongside the transformer).
3. If your power requirement is **115 Vac**, solder jumpers **W1 and W3 should be wired, but jumper W2 should not**. If your power requirement is **230 Vac**, solder jumper **W2 should be wired, but jumpers W1 and W3 should not**.

Figure 3-1 shows the location of solder jumpers W1 through W3.

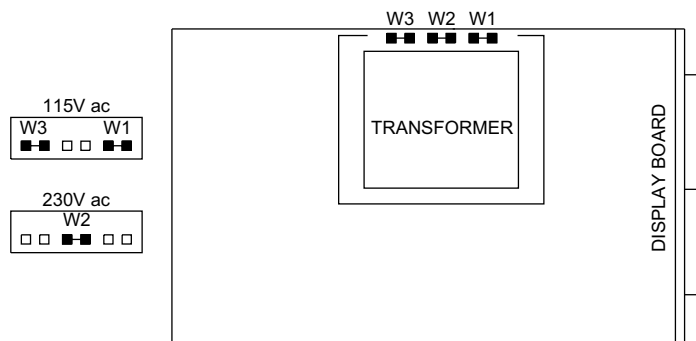

Figure 3.1 Main Board Power Jumpers (W1, W2, W3)

3.2 CHECKING MAIN BOARD POWER JUMPERS (Continued)

Figure 3-2 shows the location jumper positions on the main board.

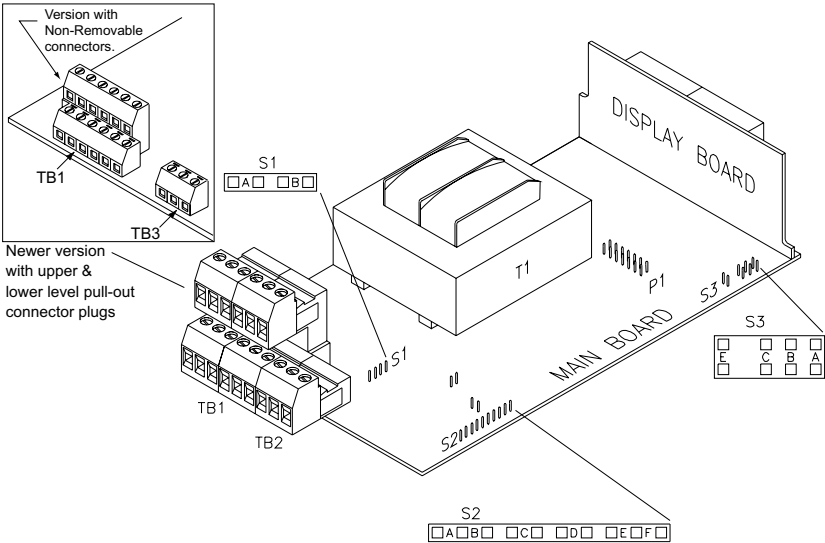

Figure 3-2. Main Board Jumper Positions

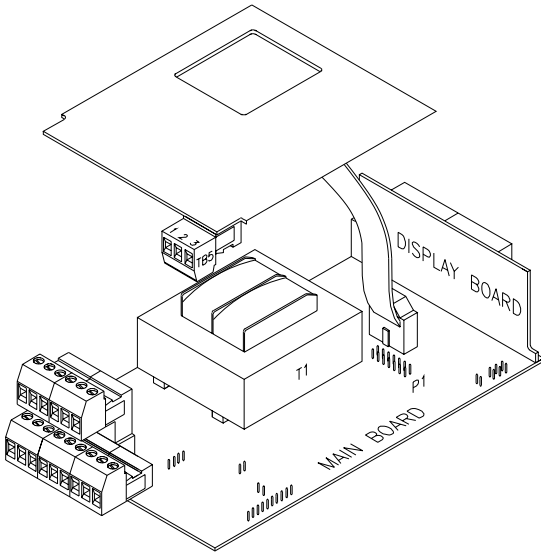

Figure 3-3. Upper Isolated Analog Output Option Board Installation

3

Getting Started

3.3 MAIN BOARD JUMPERS

Note

S2 jumpers and TP1 through TP6 (test posts) are used for calibration purposes only. Do not change.

S3 jumpers are used for the following (refer to Figure 3-2):

- * To enable or disable the front panel push-buttons
- * To allow for an extremely low resistance load for analog output
- * To disable the MENU button
- * To perform calibration procedure

Table 3-1. S3 Jumper Functions

Jumper	Description
S3-A	Install to enable front panel push-buttons. Remove to disable all front panel push-buttons
S3-B	Removed. Install for meter calibration.
S3-C	Normally removed. Install for analog voltage output when load has less than 1 K Ω impedance. Care should be taken when installing this jumper, as there is the possibility of oscillation.
S3-E	If installed without S3-B, the MENU button locks out. If you press the MENU button, the meter shows " LOCK ".

3.4 PANEL MOUNTING

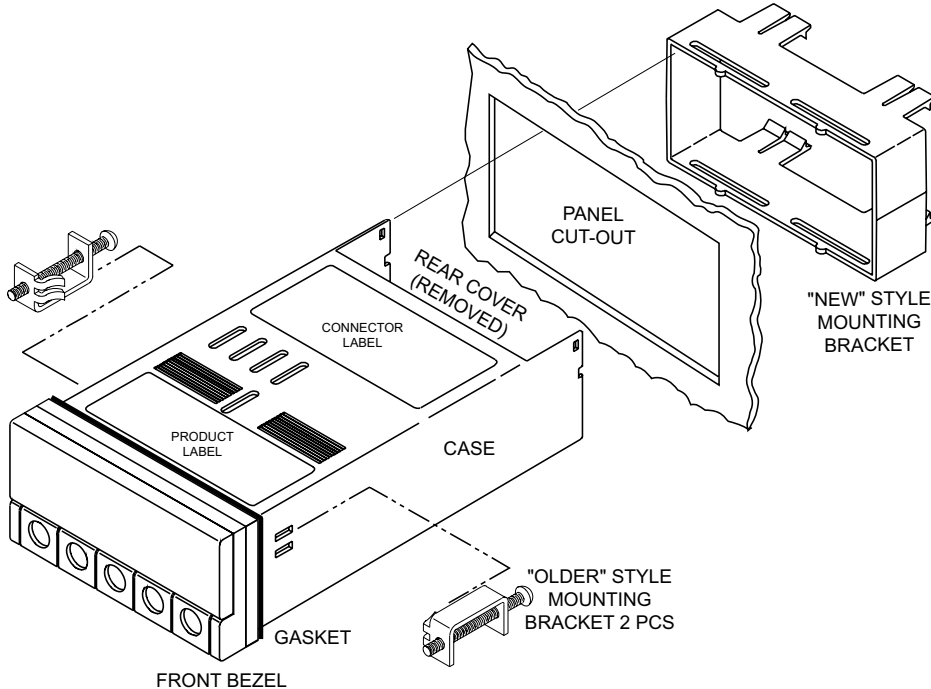
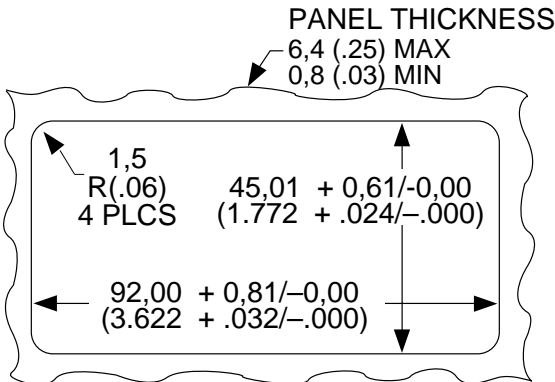

Figure 3-4. Meter - Exploded View

1. Cut a hole in your panel, as shown in Figure 3-4. For specific dimensions refer to Figure 3-5.
2. Insert the meter into the hole. Be sure the front bezel gasket is flush to the panel.
3. Slide on mounting bracket to secure.
4. Proceed to Section 3.5 to connect your sensor input and main power.



NOTE: Dimensions in Millimeters (Inches)

Figure 3-5. Panel Cut-Out

3.5 CONNECTING SENSOR INPUT

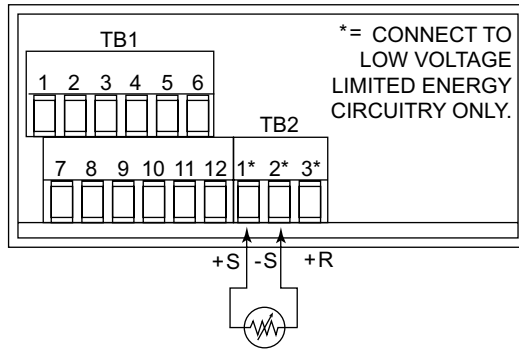

Figure 3-6. Input Connection for 300 Series

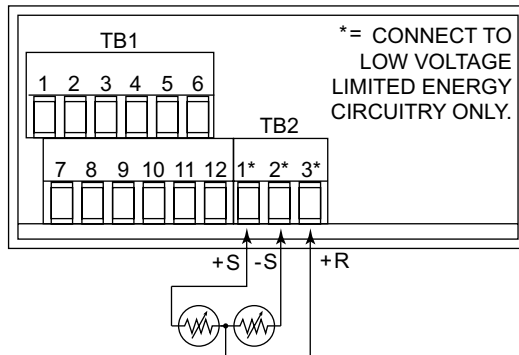

Figure 3-7. Input Connection for 700 Series (3-Wire)

3.6 CONNECTING MAIN POWER

Connect the ac main power connections as shown in Figure 3-8.



WARNING: Do not connect ac power to your meter until you have completed all input and output connections. Failure to do so may result in injury!

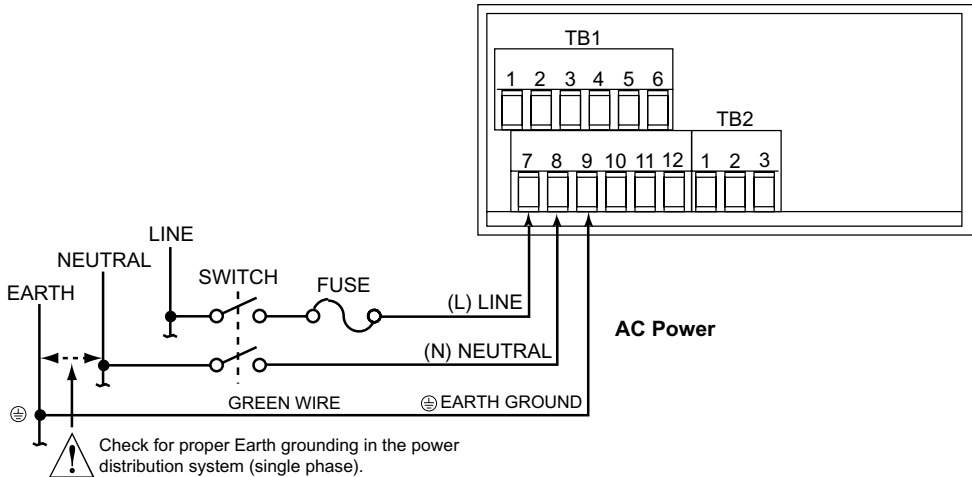

Figure 3-8. Main Power Connections (AC)

Table 3-2 shows the wire color and respective terminal connections for both USA and Europe.

Table 3-2. Power Connections

TB1	AC POWER	WIRE COLORS	
		EUROPE	USA
7	~ ac Line	Brown	Black
8	~ ac Neutral	Blue	White
9	~ ac Earth	Green/Yellow	Green

3

Getting Started

3.6 CONNECTING MAIN POWER (Continued)

Connect the DC main power connections as shown in Figure 3-9.

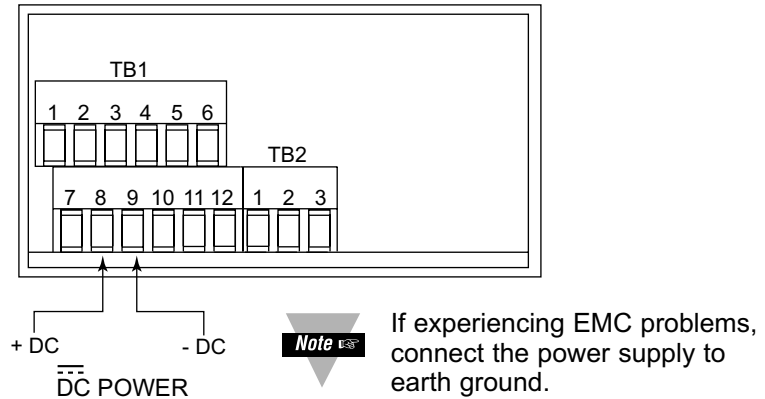

Figure 3-9. Main Power Connections (DC)

3.7 CONNECTING ANALOG AND RELAY OUTPUT OPTIONS

If applicable, connect your analog and dual relay outputs at the back of the meter as shown in Figures 3-10 and 3-11.

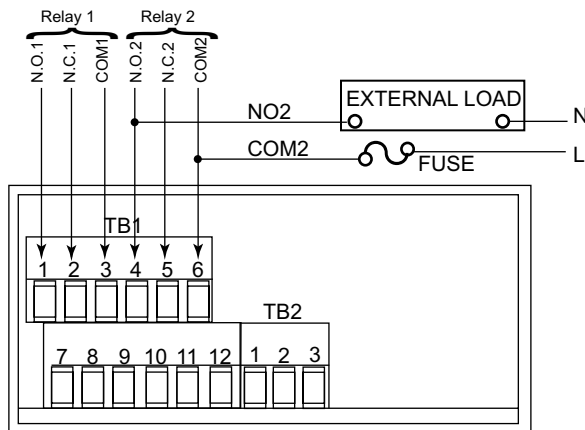

Figure 3-10. Relay Output Connections

3.7 CONNECTING ANALOG AND RELAY OUTPUT OPTIONS (Continued)

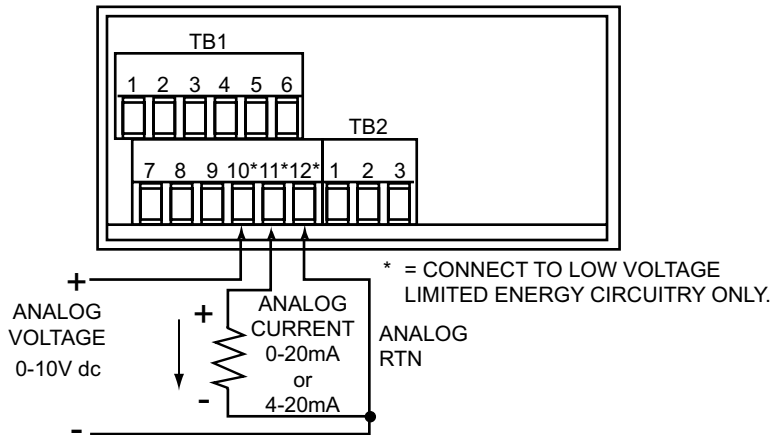
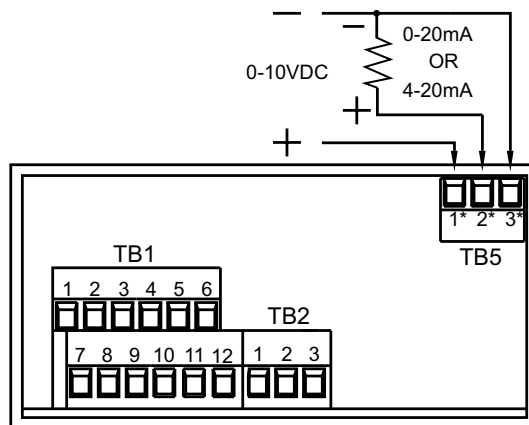

Figure 3-11. Analog Output Connections



* = CONNECT TO LOW VOLTAGE LIMITED ENERGY CIRCUITRY ONLY.

Figure 3-12. Isolated Analog Output Connections

SECTION 4. CONFIGURING THE METER

Read this section for step-by-step procedures on configuring your meter. Some menu items do not display if your meter does not have analog output or dual relay output capabilities. These menu items are noted accordingly in the following subsections.

Note Factory defaults are in bold and italics.

Note Refer to Table 7-1 for a summary list of menu configurations.

4.1 SELECTING THE INPUT TYPE ("INPT")

To select your appropriate input type signal, follow these steps:

1. Press the **MENU** button. The meter shows **"INPT"**.
2. Press the **▶/MIN** button. The meter shows one of the following (default is ***4004***):
 - * "4004" = 44004
 - * "4005" = 44005
 - * "4006" = 44006
 - * "4007" = 44007
 - * "4008" = 44008
 - * "4016" = 44016
 - * "4018" = 44018
 - * "700" = Linear 3-Wire
3. Press the **▲/MAX** button to scroll through available choices.
4. Press the **MENU** button to store your choice. The meter momentarily shows **"STRD"**, followed by **"DEC.P"** (Decimal Point).

4.2 SELECTING A DECIMAL POINT POSITION ("DEC.P")

To select a decimal point display position, follow these steps:

1. Press the **MENU** button until the meter shows "**DEC.P**".
2. Press the **▶/MIN** button. The meter shows one of the following:
 - * "**FFFF.**" - default
 - * "FFF.F"
 - * "FF.FF"
3. Press the **▲/MAX** button to scroll between available choices.
4. Press the **MENU** button to store your choice. The meter momentarily shows "**STRD**", followed by "**RD.CF**" (Reading Configuration).

Note

When you change the decimal position the meter adjusts setpoint values and setpoint deadbands. These adjustments are made according to the new decimal point. If one or more of these values overflow, the meter flashes "ER2" when you store new decimal point position value.

4.3 USING READING CONFIGURATION ("RD.CF")

To select if the meter shows in Fahrenheit or Celsius, follow these steps:

1. Press the **MENU** button until the meter shows "**RD.CF**".
2. Press the **▶/MIN** button. The meter shows one of the following:
 - * "**R.1=F**" *Fahrenheit* - default
 - * "R.1=C" Celsius

4.3 USING READING CONFIGURATION ("RD.CF") (Continued)

3. Press the ▲/MAX button to toggle between available choices.
4. Press the MENU button to store your choice. The meter momentarily shows "STRD", followed by "S1.CF" (Setpoint 1 Configuration).

4.4 USING SETPOINT 1 CONFIGURATIONS ("S1.CF")

Setpoint 1 Configurations display only if your meter has dual relay output capabilities. You may use Setpoint 1 Configuration ("S1.CF") for the following:

- * To set setpoint 1's active band above or below your chosen value
- * To select whether setpoint 1's operation is latched or unlatched

4.4.1 Setting Setpoint 1's Active Band

1. Press the MENU button until the meter shows "S1.CF".
2. Press the ►/MIN button. The meter shows one of the following:
 - * " S.1=A " *Active above setpoint* - default
 - * "S.1=B" *Active below setpoint*
3. Press the ▲/MAX button to toggle between available choices.
4. Press the ►/MIN button to select if setpoint 1 is latched or unlatched or press the MENU button to store your selection and enter "S2.CF" (Setpoint 2 configurations).

Configuring The Meter

4.4.2 Selecting if Setpoint 1 is Latched or Unlatched

1. Press the ►/MIN button. The meter shows one of the following:
 - * "S.2=L" Setpoint 1 to be latched
 - * **" S.2=U " Setpoint 1 to be unlatched** - default
2. Press the ▲/MAX button to toggle between available choices.
3. Press the MENU button to store your choice(s). The meter momentarily shows "STRD", followed by "S2.CF" (Setpoint 2 Configuration).

4.5 USING SETPOINT 2 CONFIGURATIONS ("S2.CF")

Setpoint 2 Configurations display only if your meter has dual relay output capabilities. You may use Setpoint 2 Configuration ("S2.CF") for the following:

- * To set setpoint 2's active band above or below your chosen value
- * To select whether setpoint 2's operation is latched or unlatched

4.5.1 Setting Setpoint 2's Active Band

1. Press the MENU button until the meter shows "S2.CF".
2. Press the ►/MIN button. The meter shows one of the following:
 - * **" S.1=A " Active above the setpoint** - default
 - * "S.1=B" Active below the setpoint
3. Press the ▲/MAX button to toggle between available choices.
4. Press the ►/MIN button to select if setpoint 1 is latched or unlatched or press the MENU button to store your selection and enter "S1.DB" (Setpoint 1 Deadband).

4.5.2 Selecting if Setpoint 2 is Latched or Unlatched

1. Press the ►/MIN button. The meter shows one of the following:
 - * "S.2=L" Setpoint 1 to be latched
 - * "**S.2=U**" **Setpoint 1 to be unlatched** - default
2. Press the ▲/MAX button to toggle between available choices.
3. Press the MENU button to store your selection(s). The meter momentarily shows "STRD", followed by "S1.DB" (Setpoint 1 Deadband).

4.6 SETTING THE SETPOINT 1 DEADBAND ("S1.DB")

Setpoint 1 Deadband displays only if your meter has dual relay output capabilities. Factory default deadband is 003. To change the deadband (hysteresis) of setpoint 1, follow these steps:

1. Press the MENU button until the meter shows "S1.DB".
2. Press the ►/MIN button. The meter shows the last stored number (0000 through 9999) with flashing 4th digit.
3. Press the ▲/MAX button to change the value of the flashing digit. If you continue to press the ▲/MAX button, the flashing digit's value continues to change.
4. Press the ►/MIN button to scroll to the next digit.
5. Press the MENU button to store your selection. The meter momentarily shows "STRD", followed by "S2.DB" (Setpoint 2 Deadband).

Configuring The Meter

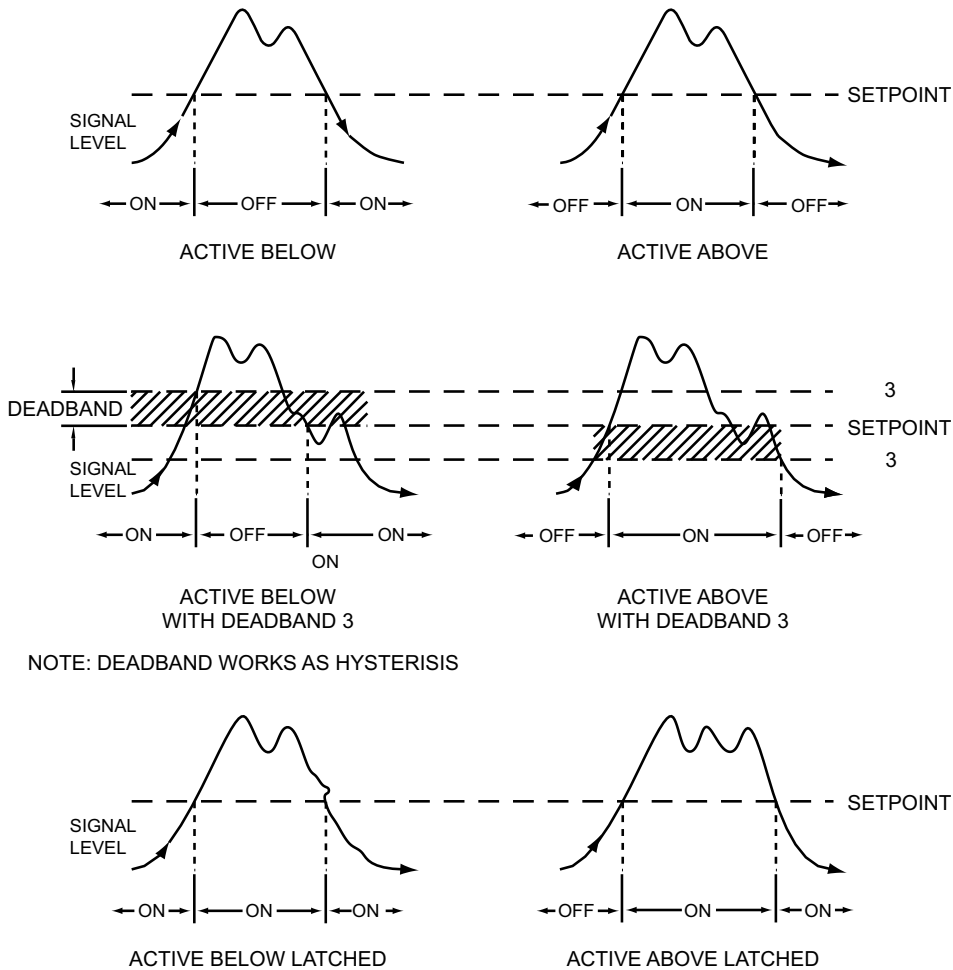

Figure 4-1. Relay Output Triggering Example

Note IE-23

To reset latched alarms you must:

1. Input a signal "OUT" of the Relay Triggering zone
2. Then press **SETPTS** and then, **RESET** button

Configuring The Meter

4.7 SETTING THE SETPOINT 2 DEADBAND ("S2.DB")

Setpoint 2 Deadband displays only if your meter has dual relay output capabilities. Factory default deadband is 003. To change the deadband (hysteresis) of setpoint 2, follow these steps:

1. Press the **MENU** button until the meter shows "**S2.DB**".
2. Press the **▶/MIN** button. The meter shows the last stored number (0000 through 9999) with flashing 4th digit.
3. Press the **▲/MAX** button to change the value of the flashing digit. If you continue to press the **▲/MAX** button, the flashing digit's value continues to change.
4. Press the **▶/MIN** button to scroll to the next digit.
5. Press the **MENU** button to store your selection. The meter momentarily shows "**STRD**", followed by "**OT.CF**" (Output Configuration).

4.8 USING OUTPUT CONFIGURATION ("OT.CF")

Output Configuration displays only if your meter has analog output capabilities. Use Output Configuration ("**OT.CF**") to select the following:

- * To enable or disable the analog output
- * To determine if the analog output is current or voltage

4.8.1 Enabling or Disabling the Analog Output

To enable or disable the analog output, follow these steps:

1. Press the **MENU** button until the meter shows "**OT.CF**".

4.8.1 Enabling or Disabling the Analog Output (Continued)

2. Press the ►/MIN button. The meter shows one of the following:
 - * "O.1=D" Analog output disabled
 - * "**O.1=E**" **Analog output enabled** - default
3. Press the ▲/MAX button to toggle between available choices.
4. Press the ►/MIN button to select the analog output as current/voltage **or** press the MENU button to store your selection (the meter momentarily shows "STRD" , followed by "OT.S.O" , Output Scale and Offset - refer to Section 4.11).

4.8.2 Selecting the Analog Output as Current or Voltage

Remember that Output Configuration displays **only** if your meter has analog output capabilities.

1. Press the ►/MIN button. The meter shows one of the following:
 - * "O.2=V" Analog output = voltage
 - * "**O.2=C**" **Analog output = current** - default
2. Press the ▲/MAX button to toggle between available choices.
3. Press the ►/MIN button to go back to selecting analog output as enabled or disabled **or** press the MENU button to store your choices (the meter momentarily shows "STRD" , followed by "OT.S.O" , Output Scale and Offset).

Configuring The Meter

4.9 USING OUTPUT SCALE AND OFFSET ("OT.S.O")

Output Scale and Offset displays only if your meter has analog output capabilities. Output Scale and Offset ("OT.S.O") scales your analog output option to be equal to the meter's display and/or any engineering units you require. You may scale the output for direct (4-20 mA, 0-10 V, etc) or reverse acting (20-4 mA, 10-0 V, etc).

1. Press the **MENU** button until the meter shows "**OT.S.O**".
2. Press the **▶/MIN** button. The meter shows "**RD 1**" (Read 1).

Note ⓘ

This is your first point of display reading.

3. Press the **▶/MIN** button again. The meter shows the last stored number (-1999 through 9999) with flashing 4th digit.
4. Press the **▲/MAX** button to change the value of Read 1.
5. Press the **▶/MIN** button to scroll to the next digit.
6. Press the **MENU** button to store your selection. The meter shows "**OUT.1**" (Output 1). **Note:** *This starting analog signal corresponds to your Read 1 display.*
7. Press the **▶/MIN** button. The meter shows the selected output.

Note ⓘ

*If you select "**O.2=V**" for voltage, the maximum signal you may select is 10.00 for an 0-10 Vdc signal output. If you select "**O.2=C**" for current, the maximum signal you may select is 20.00 for 0-20 or 4-20 mA dc signal output.*

8. Press the **▲/MAX** button to enter the output 1 signal selection. If you continue to press the **▲/MAX** button, the flashing digit's value continues to change.

4.9 USING OUTPUT SCALE AND OFFSET ("OT.S.O") (Continued)

9. Press the **▶/MIN** button to scroll to the next digit.
10. Press the **MENU** button to store your selection. The meter shows **"RD 2"** (Read 2). **Note:** *This is your second point of display reading.*
11. Press the **▶/MIN** button. The meter shows the last stored number (-1999 through 9999) with flashing 4th digit.
12. Press the **▲/MAX** button to change the value of the flashing digit. If you continue to press the **▲/MAX** button, the flashing digit's value continues to change.
13. Press the **▶/MIN** button to scroll to the next digit.
14. Press the **MENU** button to store your selection. The meter shows **"OUT.2"** (Output 2). **Note:** *This analog signal should correspond to your Read 2 display.*
15. Press the **▶/MIN** button. The meter shows the selected output.

Note U33

If you select "O.2=V" for voltage, the maximum signal you may select is 10.00 for an 0-10 Vdc signal output. If you select "O.2=C" for current, the maximum signal you may select is 20.00 for a 0-20 or 4-20 mA dc signal output.

Configuring The Meter

4.9 USING OUTPUT SCALE AND OFFSET ("OT.S.O") (Continued)

16. Press the **▲/MAX** button to change the value of the flashing digit. If you continue to press the **▲/MAX** button, the flashing digit's value continues to change.
17. Press the **▶/MIN** button to scroll to the next digit.
18. Press the **MENU** button to store your selection. The meter momentarily shows "**STRD**", followed "**TH.OF**".



CAUTION: If the meter shows all flashing values on any item, the value has overflowed. Press the **▲/MAX** button to start new values.

4.9.1 Example for Output Scale and Offset

You want to send 4-20 mA output for 32.0° to 212.0°F. The meter has .1 degree resolution. Complete the following steps:

1. Press the **MENU** button until the meter shows "**OT.S.O**".
2. Press the **▶/MIN** button. The meter shows "**RD 1**" (Read 1).
3. Press the **▶/MIN** button again to show the existing value.
4. Change the value of "**RD 1**" to 32.0 by pressing the **▲/MAX** and the **▶/MIN** buttons.

4.9.1 Example for Output Scale and Offset (Continued)

5. Press the **MENU** button to store your selection. The meter shows "**OUT.1**" (Output 1).
6. Press the **▶/MIN** button again to show the existing value.
7. Change the value of "**OUT.1**" to 04.00 by pressing the **▲/MAX** and the **▶/MIN** buttons.
8. Press the **MENU** button to store your selection. The meter shows "**RD 2**" (Read 2).
9. Press the **▶/MIN** button to show the existing value.
10. Change the value of "**RD 2**" to 212.0 by pressing the **▲/MAX** and the **▶/MIN** buttons.
11. Press the **MENU** button to store your selection. The meter shows "**OUT.2**" (Output 2).
12. Press the **▶/MIN** button to show the existing value.
13. Change the value of "**OUT.2**" to 20.00 by pressing the **▲/MAX** and the **▶/MIN** buttons.
14. Press the **MENU** button to store your selection. The meter shows "**STRD**".

Configuring The Meter

4.10 CORRECTING THERMISTOR TEMPERATURE OFFSET ERROR ("TH.OF")

Before You Correct the Thermistor Temperature Offset

Thermistor Temperature Offset Error Correction enables you to compensate for temperature offset error due to the thermistor transducer:

Thermistor temperature curves are highly nonlinear, therefore take care in obtaining the offset error (which is mainly due to the probe lead resistance). To obtain the best and most accurate result, study the following tables. Determine your input type and check the corresponding maximum permissible offset error and equivalent lead resistance.

Table 4-1. Maximum Correctable Offset Error and Equivalent Lead Resistance 44004, 44005 and 44006 Input Types

#	Temperature	44004		44005		44006	
		°C (°F)	Ohm	°C (°F)	Ohm	°C (°F)	Ohm
1	60°C (140°F)	1(1.8)	20	.7(1.26)	20	.20(.36)	20
2	80°C (176°F)	1(1.8)	9	1(1.8)	12	.5(.9)	20
3	100°C (212°F)	1(1.8)	4.5	1(1.8)	6	1(1.8)	20
4	120°C (248°F)	1(1.8)	2.3	1(1.8)	3.1	1(1.8)	12
5	140°C (284°F)	2(3.6)	2.6	1.5(2.7)	2.7	1(1.8)	7

Configuring The Meter

4.10 CORRECTING THERMISTOR TEMPERATURE OFFSET ERROR ("TH.OF") (Continued)

**Table 4-2. Maximum Permissible Offset Error and
Equivalent Lead Resistance 44007, 44008 and 44016 Input Types**

#	Temperature	44007		44008		44016	
		°C (°F)	Ohm	°C (°F)	Ohm	°C (°F)	Ohm
1	60°C (140°F)	.5(.9)	20	-	-	.2(.36)	20
2	80°C (176°F)	1(1.8)	20	.2(.36)	20	.5(.9)	20
3	100°C (212°F)	1(1.8)	10	.3(.54)	20	1(1.8)	20
4	120°C (248°F)	1(1.8)	5	.6(1.0)	20	1(1.8)	10
5	140°C (284°F)	1(1.8)	2.9	1(1.8)	17	1(1.8)	6

**Table 4-3. Maximum Permissible Offset Error and
Equivalent Lead Resistance 44018 Input Types**

#	Temperature	44018/700	
		°C (°F)	Ohm
1	60°C (140°F)	-	-
2	80°C (176°F)	1(1.8)	147
3	100°C (212°F)	1(1.8)	88
4	120°C (248°F)	-	-
5	140°C (284°F)	-	-

Configuring The Meter

4.10 CORRECTING THERMISTOR TEMPERATURE OFFSET ERROR ("TH.OF") (Continued)

The following steps enable you to calibrate for the offset.

1. Press the **MENU** button until the meter shows "**TH.OF**".
2. Press the **▶/MIN** button. The meter will show the previous offset value (4th digit flashes).
3. Press the **▶/MIN** button again. The meter will show the reading temperature (no digits flash).
4.
 - a. If the value is correct, press the **MENU** button. The meter will show "**STRD**" and 0 value will be entered at the offset.
 - b. If the value is not correct, enter the actual temperature using the **▲/MAX** and the **▶/MIN** buttons.
5. Press the **MENU** button to store new reading temperature.

NOTE 1: Select a higher temperature for a more accurate result.

NOTE 2: If values are greater than the maximum correctable offset error the meter will flash "**ER**" and will not store the new values.

NOTE 3: Temperature unit is either Celsius or Fahrenheit and always displays at 0.01 degree resolution and automatically changes to .1 degree resolution if necessary.

Selecting Setpoint Values

SECTION 5. SELECTING SETPOINT VALUES

If your meter has dual relay output capabilities, follow the steps below to select values for Setpoint 1 and Setpoint 2.

1. Press the **SETPTS** button. The meter momentarily shows "**SP1**" (Setpoint 1), followed by the last stored value with flashing 4th digit. The factory default for "**SP1**" is 000.0.
2. Press the **▲/MAX** button to change the value of Setpoint 1.
3. Press the **▶/MIN** button to scroll to the next digit.
4. Press the **SETPTS** button to store your selection. The meter momentarily shows "**SP2**" (Setpoint 2), followed by the last stored value with flashing 4th digit. The factory default for "**SP2**" is 000.0.
5. Press the **▲/MAX** button to change the value of Setpoint 2.
6. Press the **▶/MIN** button to scroll to the next digit.
7. Press the **SETPTS** button to store new values. The meter momentarily shows "**STRD**", "**RUN**" and then enters the run mode.

Note

You may press the **RESET** button anytime during this routine to return to the run mode.

Note

If your meter does not have dual relay output capabilities, the **SETPTS** button's only function is to display "**RUN**" and return the meter to the run mode.

SECTION 6. DISPLAY MESSAGES

Table 6-1. Display Messages

MESSAGE	DESCRIPTION
THERMISTOR	Thermistor meter
RST	Hard (power on) reset
INPT	Input type
DEC.P	Decimal point
RD.CF	Reading configuration
S1.CF	Setpoint 1 configuration
S2.CF	Setpoint 2 configuration
S1.DB	Setpoint 1 deadband
S2.DB	Setpoint 2 deadband
OT.CF	Output configuration
OT.S.O	Output scale and offset
TH.OF	Thermistor Temperature Offset Error Correction
±OPN	Sensor break or temperature outside range
9999	Value overflow in setpoint/menu peak deviation routines
-1999	Value overflow in setpoint/menu peak deviation routine
ER1	2 coordinate format programming error
PEAK	Peak value
VALY	Valley value
PK.RS	Peak reset
SP.RS	Reset setpoints
SP1	Setpoint 1 value
SP2	Setpoint 2 value
ER2	One or more of these items have overflowed due to decimal point change: setpoint values, setpoint deadbands, proportional bands or manual reset.
ER3	TH.OF is outside the range

Menu Configuration Displays

SECTION 7. MENU CONFIGURATION DISPLAYS

Table 7-1. Configuration Menu

(Defaults in bold and italics)

MENU	▲/MIN	►/MAX
INPT Input Type	Show input choices:	44004 <i>-80° to +150°C</i> 44005 -80° to +150°C 44006 -80° to +150°C 44007 -80° to +150°C 44008 -40° to +150°C 44016 -80° to +150°C 55018 -30° to +100°C 700 -30° to +100°C
DEC.P Decimal Point	Show decimal point position	FFFF. FFF.F FF.FF
RD.CF Reading Configuration	R.1	C: Celsius F: Fahrenheit 2: Two-Point Calibration 3: Three-Point Calibration
S1.CF Setpoint 1 Configurations	S.1 S.2	A: Active above B: Active below U: Unlatched L: Latched
S2.CF Setpoint 2 Configurations	S.1 S.2	A: Active above B: Active below U: Unlatched L: Latched
S1.DB Setpoint 1 Configurations	Scroll right one digit	Change flashing digit's value
S2.DB Setpoint 2 Configurations	Scroll right one digit	Change flashing digit's value

Menu Configuration Displays

SECTION 7. MENU CONFIGURATION (Continued)

Table 7-1. Configuration Menu (Continued)

(Defaults in bold and italics)

MENU	▲/MIN	▶/MAX
OT.CF Output Configuration	0.1	D: Disabled E: Enabled
Analog Output Option	0.2	V: Voltage Analog out C: Current Analog out
OT.S.O Output Scale & Offset		
Enter new value & show "OUT1"	Show "RD 1" & prior value Scroll right one digit	Change flashing digit's value
Enter new value & show "RD 2"	Show prior value Scroll right one digit	Change flashing digit's value
Enter new value & show "OUT2"	Show prior value Scroll right one digit	Change flashing digit's value
TH.OF Temperature Offset Error Correction	Show prior offset value Scroll right one digit	Change flashing digit's value

Menu Configuration Displays

SECTION 7. MENU CONFIGURATION (Continued)

Table 7-2. Run Mode Displays

Display	▶/MIN	▲/MAX	RESET	Description
PEAK Peak Reading		Shows peak reading. Press again to return to normal operating mode without resetting.	Reset peak reading when in this mode.	Shows highest reading since last reset.
VALY		Shows valley reading. Press again to return to normal operating mode without resetting.		Shows lowest reading since last reset.
SP.RS				LATCHED RESET Press RESET button to reset your setpoints.

SECTION 8. SETPOINT CONFIGURATION DISPLAYS**Table 8-1. Setpoint Configuration Displays**

MENU	▶/MIN	▲/MAX	DESCRIPTION
SP 1 Setpoint 1	Scroll right one digit	Change flashing digit's value	Select from -1999 through 9999
SP 2 Setpoint 2	Scroll right one digit	Change flashing digit's value	Select from -1999 through 9999

SECTION 9. SPECIFICATIONS

INPUT SIGNAL

Thermistor Types/ Temperature Ranges	44004, 44005, 44006, 44007, 44016, -80° through +150°C (-112° through 302°F)
	44008, 44032 -40° through +150°C (-40° through 302°F)
	44018, 700 -30° to +100°C (-22° through 212°F)
Isolation	Dielectric strength to 2500 V transient per 3 mm spacing based on EN 61010 for 260 Vrms or dc working voltage
Noise Rejection	Normal Mode Rejection (NMR) = 60 dB Common Mode Rejection (CMR) = 120 dB
Display	LED 14 segment, 13.8 mm (0.54")
Symbol	

ANALOG TO DIGITAL

Technique	Dual slope, polarity automatic
Internal Resolution	15 bits
Read rate	3/sec

ACCURACY AT 25°C

	±0.2°C
Temperature Repeatability	±0.1°C
Temperature Stability	0.05°C/°C
Step Response Time	4 to 5 seconds
Warm Up to Rated Accuracy	30 min

SECTION 9. SPECIFICATIONS (Continued)

ALARM OUTPUTS (Optional)

2 Form "C" on/off relays. Configurable for latched and unlatched by software.

Max current: 5 AMPS, resistive load

Max voltage: 250 Vac or 30 Vdc

ANALOG OUTPUT (Optional)

Signal Type:	Current or voltage
Signal Level:	Current: 10 V max compliance at 20 mA output Voltage: 20 mA max for 0-10 V output
Function:	May be assigned to a display range or proportional control output with setpoint #1 when used as a control output.
Linearity:	0.2%
Step Response Time:	2 - 3 seconds to 99% of the final value

ISOLATED ANALOG OUTPUT (TB5, if applicable)

Same as non-isolated analog output except isolated to 1000 Vdc.

Signal Type:	Current or voltage
Signal Level:	Current: 10 V max compliance at 20 mA output Voltage: 20 mA max for 0-10 V output
Function:	May be assigned to a display range or proportional control output with setpoint #1 when used as a control output.
Linearity:	0.2%
Step Response Time:	2 - 3 seconds to 99% of the final value

Note

Only one analog output is available on each unit and it must be factory installed.

SECTION 9. SPECIFICATIONS (Continued)

INPUT POWER INFORMATION

~ ac units 115/230 V~(ac) ±10%, 50/60 Hz
 7 W max, power consumption (Non-Isolated Analog Output)
 8 W max, power consumption (Isolated Analog Output)

=== dc units 10-32 Vdc
 6 W max, power consumption (Non-Isolated Analog Output)
 7 W max, power consumption (Isolated Analog Output)

External Fuse Protection Recommended:

IEC 127-2/III	
Power	Fuse
115 V	125 mA @ 250 (T)
230 V	63 mA @ 250 (T)
UL 248-14 (Listed Fuse)	
Power	Fuse
115 V	175 mA @ 250 V Slow-Blow
230 V	80 mA @ 250 V Slow-Blow

ENVIRONMENT

Operating Temperature 0 to 50°C (32° to 122°F)
 Storage Temperature -40 through 85°C (-40° to 185°F)
 Relative Humidity 90% at 40°C (non-condensing)

MECHANICAL

Panel cutout 1/8 DIN 3.62 x 1.8" (45 x 92mm)
 Weight 1.27 lb (574 g)
 Case material Polycarbonate, 94 V-O UL rated

SECTION 10. FACTORY PRESET VALUES

Table 10-1. Factory Preset Values

Menu Item	Factory Preset Values
INPT	Input Type: 4004
DEC.P	Decimal Point Position: FFF.F
RD.CF	Reading Configuration: R.1=F (Fahrenheit)
S1.CF	Setpoint 1 Configuration: S.1=A (Setpoint is active above) S.2=U (Setpoint is unlatched)
S2.CF	Setpoint 2 Configuration: S.1=A (Setpoint is active above) S.2=U (Setpoint is unlatched)
S1.DB	Setpoint 1 Deadband: 003.0
S2.DB	Setpoint 2 Deadband: 003.0
OT.CF	Output Configuration: O.1=E (Analog output option is enabled) O.2=C (Analog output option is current)
OT.S.O	Output Scale and Offset: 032° - 212.0°F = 4-20 mA dc
SP1	Setpoint 1 Value: 000.0
SP2	Setpoint 2 Value: 000.0

CE APPROVALS INFORMATION

 This product conforms to the EMC directive 89/336/EEC amended by 93/68/EEC, and with the European Low Voltage Directive 72/23/EEC.

Electrical Safety EN61010-1:2001

Safety requirements for electrical equipment for measurement, control and laboratory.

Double Insulation

Pollution Degree 2

Dielectric withstand Test per 1 min

- Power to Input/Output: 2300 Vac (3250 Vdc)
- Power to Input/Output: 500 Vac (720 Vdc)
(Low Voltage dc Power Option*)
- Power to Relays Output: 2300 Vac (3250 Vdc)
- Relay 1 to Relay 2: 2300 Vac (3250 Vdc)
- Isolated Analog to Inputs: 1000 Vac (1420 Vdc)
- Analog to Inputs: No Isolation

Measurement Category I

Category I are measurements performed on circuits not directly connected to the Mains Supply (power). Maximum Line-to-Neutral working voltage is 50 Vac/dc. This unit should not be used in Measurement Categories II, III, IV.

Transients Overvoltage Surge (1.2 / 50uS pulse)

- Input Power: 2500 V
- Input Power: 500 V
(Low Voltage dc Power Option*)
- Isolated Analog: 500 V
- Input/Output Signals: 500 V

Note: *Units configured for external low power dc voltage, 10-32 Vdc (Basic Insulation)

EMC EN61326:1997 + and A1:1998 + A2:2001

Immunity and Emissions requirements for electrical equipment for measurement, control and laboratory.

- EMC Emissions Table 4, Class B of EN61326
- EMC Immunity** Table 1 of EN61326

Note: **I/O signal and control lines require shielded cables and these cables must be located on conductive cable trays or in conduits. Furthermore, the length of these cables should not exceed 30 meters



Refer to the EMC and Safety installation considerations (Guidelines) of this manual for additional information.

Warranty/Disclaimer

NEWPORT Electronics, Inc. warrants this unit to be free of defects in materials and workmanship for a period of one (1) year from the date of purchase. In addition to NEWPORT's standard warranty period, NEWPORT Electronics will extend the warranty period for one (1) additional year if the warranty card enclosed with each instrument is returned to NEWPORT.

If the unit should malfunction, it must be returned to the factory for evaluation. NEWPORT's Customer Service Department will issue an Authorized Return (AR) number immediately upon phone or written request. Upon examination by NEWPORT, if the unit is found to be defective it will be repaired or replaced at no charge. NEWPORT's WARRANTY does not apply to defects resulting from any action of the purchaser, including but not limited to mishandling, improper interfacing, operation outside of design limits, improper repair, or unauthorized modification. This WARRANTY is VOID if the unit shows evidence of having been tampered with or shows evidence of being damaged as a result of excessive corrosion; or current, heat, moisture or vibration; improper specification; misapplication; misuse or other operating conditions outside of NEWPORT's control. Components which wear are not warranted, including but not limited to contact points, fuses, and triacs.

NEWPORT is pleased to offer suggestions on the use of its various products. However, NEWPORT neither assumes responsibility for any omissions or errors nor assumes liability for any damages that result from the use of its products in accordance with information provided by NEWPORT, either verbal or written. NEWPORT warrants only that the parts manufactured by it will be as specified and free of defects. NEWPORT MAKES NO OTHER WARRANTIES OR REPRESENTATIONS OF ANY KIND WHATSOEVER, EXPRESSED OR IMPLIED, EXCEPT THAT OF TITLE, AND ALL IMPLIED WARRANTIES INCLUDING ANY WARRANTY OF MERCHANTABILITY AND FITNESS FOR A PARTICULAR PURPOSE ARE HEREBY DISCLAIMED. LIMITATION OF LIABILITY: The remedies of purchaser set forth herein are exclusive and the total liability of NEWPORT with respect to this order, whether based on contract, warranty, negligence, indemnification, strict liability or otherwise, shall not exceed the purchase price of the component upon which liability is based. In no event shall NEWPORT be liable for consequential, incidental or special damages.

CONDITIONS: Equipment sold by NEWPORT is not intended to be used, nor shall it be used: (1) as a "Basic Component" under 10 CFR 21 (NRC), used in or with any nuclear installation or activity; or (2) in medical applications or used on humans. Should any Product(s) be used in or with any nuclear installation or activity, medical application, or used on humans, or misused in any way, NEWPORT assumes no responsibility as set forth in our basic WARRANTY / DISCLAIMER language, and additionally purchaser will indemnify NEWPORT and hold NEWPORT harmless from any liability or damage whatsoever arising out of the use of the Product(s) in such a manner.

Return Requests/Inquiries

Direct all warranty and repair requests/inquiries to the NEWPORT Customer Service Department. BEFORE RETURNING ANY PRODUCT(S) TO NEWPORT, PURCHASER MUST OBTAIN AN AUTHORIZED RETURN (AR) NUMBER FROM NEWPORT'S CUSTOMER SERVICE DEPARTMENT (IN ORDER TO AVOID PROCESSING DELAYS). The assigned AR number should then be marked on the outside of the return package and on any correspondence.

The purchaser is responsible for shipping charges, freight, insurance and proper packaging to prevent breakage in transit.

FOR **WARRANTY** RETURNS, please have the following information available BEFORE contacting NEWPORT:

1. P.O. number under which the product was PURCHASED,
2. Model and serial number of the product under warranty, and
3. Repair instructions and/or specific problems relative to the product.

FOR **NON-WARRANTY** REPAIRS, consult NEWPORT for current repair charges. Have the following information available BEFORE contacting NEWPORT:

1. P.O. number to cover the COST of the repair,
2. Model and serial number of product, and
3. Repair instructions and/or specific problems relative to the product.

NEWPORT's policy is to make running changes, not model changes, whenever an improvement is possible. This affords our customers the latest in technology and engineering. NEWPORT is a registered trademark of NEWPORT ELECTRONICS, INC.

© Copyright 2005 NEWPORT ELECTRONICS, INC. All rights reserved. This document may not be copied, photocopied, reproduced, translated, or reduced to any electronic medium or machine-readable form, in whole or in part, without prior written consent of NEWPORT ELECTRONICS, INC.

For immediate technical or application assistance please call:

1-800-6397678®
1-800-NEWPORT

Newport Electronics, Inc.
2229 South Yale Street • Santa Ana, CA • 92704 • U.S.A.
TEL: (714) 540-4914 • FAX: (203) 968-7311
Toll Free: 1-800-639-7678 • www.newportUS.com • e-mail: info@newportUS.com
ISO 9001 Certified

Newport Technologies, Inc.
976 Bergar • Laval (Quebec) • H7L 5A1 • Canada
TEL: (514) 335-3183 • FAX: (514) 856-6886
Toll Free: 1-800-639-7678 • www.newport.ca • e-mail: info@newport.ca

Newport Electronics, Ltd.
One Omega Drive • River Bend Technology Centre
Northbank, Irlam • Manchester M44 5BD • United Kingdom
Tel: +44 161 777 6611 • FAX: +44 161 777 6622
Toll Free: 0800 488 488 • www.newportuk.co.uk • e-mail: sales@newportuk.co.uk

Newport Electronics B.V.
Postbus 8034 • 1180 LA Amstelveen • The Netherlands
TEL: +31 20 3472121 • FAX: +31 20 6434643
Toll Free: 0800 0993344 • www.newport.nl • e-mail: info@newport.nl

Newport Electronics spol s.r.o.
Frystatska 184, 733 01 Karviná • Czech Republic
TEL: +420 59 6311899 • FAX: +420 59 6311114
Toll Free: 0800-1-66342 • www.newport.cz • e-mail: info@newport.cz

Newport Electronics GmbH
Daimlerstrasse 26 • D-75392 Deckenpfronn • Germany
TEL: 49 7056 9398-0 • FAX: 49 7056 9398-29
Toll Free: 0800 / 6397678 • www.newport.de • e-mail: sales@newport.de

Newport Electronique S.A.R.L.
11, rue Jacques Cartier • 78280 Guyancourt • France
TEL: +33 1 61 37 29 00 • FAX: +33 1 30 57 54 27
Toll Free: 0800 466 342 • www.newport.fr • e-mail: sales@newport.fr

Mexico and Latin America
FAX: 001 (203) 359-7807
En Español: 001 (203) 359-7803

NEWPORTnetSM On-Line Service www.newportUS.com	Internet e-mail info@newportUS.com
--	--

 **NEWPORT** Electronics, Inc.