



MICROCHIP

**MIC19215
Dual Boost/SEPIC
Evaluation Board
User's Guide**

Note the following details of the code protection feature on Microchip devices:

- Microchip products meet the specification contained in their particular Microchip Data Sheet.
- Microchip believes that its family of products is one of the most secure families of its kind on the market today, when used in the intended manner and under normal conditions.
- There are dishonest and possibly illegal methods used to breach the code protection feature. All of these methods, to our knowledge, require using the Microchip products in a manner outside the operating specifications contained in Microchip's Data Sheets. Most likely, the person doing so is engaged in theft of intellectual property.
- Microchip is willing to work with the customer who is concerned about the integrity of their code.
- Neither Microchip nor any other semiconductor manufacturer can guarantee the security of their code. Code protection does not mean that we are guaranteeing the product as "unbreakable."

Code protection is constantly evolving. We at Microchip are committed to continuously improving the code protection features of our products. Attempts to break Microchip's code protection feature may be a violation of the Digital Millennium Copyright Act. If such acts allow unauthorized access to your software or other copyrighted work, you may have a right to sue for relief under that Act.

Information contained in this publication regarding device applications and the like is provided only for your convenience and may be superseded by updates. It is your responsibility to ensure that your application meets with your specifications. MICROCHIP MAKES NO REPRESENTATIONS OR WARRANTIES OF ANY KIND WHETHER EXPRESS OR IMPLIED, WRITTEN OR ORAL, STATUTORY OR OTHERWISE, RELATED TO THE INFORMATION, INCLUDING BUT NOT LIMITED TO ITS CONDITION, QUALITY, PERFORMANCE, MERCHANTABILITY OR FITNESS FOR PURPOSE. Microchip disclaims all liability arising from this information and its use. Use of Microchip devices in life support and/or safety applications is entirely at the buyer's risk, and the buyer agrees to defend, indemnify and hold harmless Microchip from any and all damages, claims, suits, or expenses resulting from such use. No licenses are conveyed, implicitly or otherwise, under any Microchip intellectual property rights unless otherwise stated.

Microchip received ISO/TS-16949:2009 certification for its worldwide headquarters, design and wafer fabrication facilities in Chandler and Tempe, Arizona; Gresham, Oregon and design centers in California and India. The Company's quality system processes and procedures are for its PIC® MCUs and dsPIC® DSCs, KEELOQ® code hopping devices, Serial EEPROMs, microperipherals, nonvolatile memory and analog products. In addition, Microchip's quality system for the design and manufacture of development systems is ISO 9001:2000 certified.

**QUALITY MANAGEMENT SYSTEM
CERTIFIED BY DNV
= ISO/TS 16949 =**

Trademarks

The Microchip name and logo, the Microchip logo, AnyRate, AVR, AVR logo, AVR Freaks, BeaconThings, BitCloud, CryptoMemory, CryptoRF, dsPIC, FlashFlex, flexPWR, Heldo, JukeBlox, KEELOQ, KEELOQ logo, Klear, LANCheck, LINK MD, maXStylus, maXTouch, MediaLB, megaAVR, MOST, MOST logo, MPLAB, OptoLyzer, PIC, picoPower, PICSTART, PIC32 logo, Prochip Designer, QTouch, RightTouch, SAM-BA, SpyNIC, SST, SST Logo, SuperFlash, tinyAVR, UNI/O, and XMEGA are registered trademarks of Microchip Technology Incorporated in the U.S.A. and other countries.

ClockWorks, The Embedded Control Solutions Company, EtherSynch, Hyper Speed Control, HyperLight Load, IntelliMOS, mTouch, Precision Edge, and Quiet-Wire are registered trademarks of Microchip Technology Incorporated in the U.S.A.

Adjacent Key Suppression, AKS, Analog-for-the-Digital Age, Any Capacitor, AnyIn, AnyOut, BodyCom, chipKIT, chipKIT logo, CodeGuard, CryptoAuthentication, CryptoCompanion, CryptoController, dsPICDEM, dsPICDEM.net, Dynamic Average Matching, DAM, ECAN, EtherGREEN, In-Circuit Serial Programming, ICSP, Inter-Chip Connectivity, JitterBlocker, KlearNet, KlearNet logo, Mindi, MiWi, motorBench, MPASM, MPF, MPLAB Certified logo, MPLIB, MPLINK, MultiTRAK, NetDetach, Omniscient Code Generation, PICDEM, PICDEM.net, PICKit, PICtail, PureSilicon, QMatrix, RightTouch logo, REAL ICE, Ripple Blocker, SAM-ICE, Serial Quad I/O, SMART-I.S., SQI, SuperSwitcher, SuperSwitcher II, Total Endurance, TSHARC, USBCheck, VariSense, ViewSpan, WiperLock, Wireless DNA, and ZENA are trademarks of Microchip Technology Incorporated in the U.S.A. and other countries.

SQTP is a service mark of Microchip Technology Incorporated in the U.S.A.

Silicon Storage Technology is a registered trademark of Microchip Technology Inc. in other countries.

GestIC is a registered trademark of Microchip Technology Germany II GmbH & Co. KG, a subsidiary of Microchip Technology Inc., in other countries.

All other trademarks mentioned herein are property of their respective companies.

© 2017, Microchip Technology Incorporated, All Rights Reserved.
ISBN: 978-1-5224-1526-8

Object of Declaration: MCP19215 Dual Boost/SEPIC Evaluation Board

EU Declaration of Conformity

This declaration of conformity is issued by the manufacturer.

The development/evaluation tool is designed to be used for research and development in a laboratory environment. This development/evaluation tool is not a Finished Appliance, nor is it intended for incorporation into Finished Appliances that are made commercially available as single functional units to end users under EU EMC Directive 2004/108/EC and as supported by the European Commission's Guide for the EMC Directive 2004/108/EC (8th February 2010).

This development/evaluation tool complies with EU RoHS2 Directive 2011/65/EU.

This development/evaluation tool, when incorporating wireless and radio-telecom functionality, is in compliance with the essential requirement and other relevant provisions of the R&TTE Directive 1999/5/EC and the FCC rules as stated in the declaration of conformity provided in the module datasheet and the module product page available at www.microchip.com.

For information regarding the exclusive, limited warranties applicable to Microchip products, please see Microchip's standard terms and conditions of sale, which are printed on our sales documentation and available at www.microchip.com.

Signed for and on behalf of Microchip Technology Inc. at Chandler, Arizona, USA.

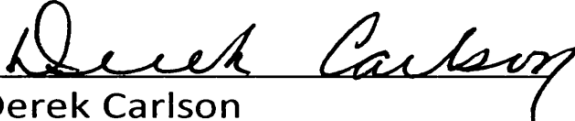
Derek Carlson

VP Development Tools

11-NOV-16
Date

MCP19215 Dual Boost/SEPIC Evaluation Board User's Guide

NOTES:



Table of Contents

Preface	7
Chapter 1. Product Overview	
1.1 Introduction	11
1.2 MCP19215 Device – Short Overview	11
1.3 What is the MCP19215 Dual Boost/SEPIC Evaluation Board?	12
1.4 What Does the MCP19215 Dual Boost/SEPIC Evaluation Board Kit Include?	13
Chapter 2. Installation and Operation	
2.1 Introduction	15
2.2 MCP19215 Dual Boost/SEPIC Evaluation Board Features	15
2.3 Getting Started	15
2.4 Setup Procedure	16
2.5 Operating the MCP19215 Dual Boost/SEPIC Evaluation Board	18
2.6 Typical Performance Data and Waveforms	20
Appendix A. Schematic and Layouts	
A.1 Introduction	25
A.2 Board – Schematic	26
A.3 Board – Top Silk	27
A.4 Board – Top Copper and Silk	27
A.5 Board – Top Copper	28
A.6 Board – Bottom Copper	28
A.7 Board – Bottom Copper and Silk	29
A.8 Board – Bottom Silk	29
Appendix B. Bill of Materials (BOM)	31
Worldwide Sales and Service	33

MCP19215 Dual Boost/SEPIC Evaluation Board User's Guide

NOTES:

Preface

NOTICE TO CUSTOMERS

All documentation becomes dated, and this manual is no exception. Microchip tools and documentation are constantly evolving to meet customer needs, so some actual dialogs and/or tool descriptions may differ from those in this document. Please refer to our web site (www.microchip.com) to obtain the latest documentation available.

Documents are identified with a “DS” number. This number is located on the bottom of each page, in front of the page number. The numbering convention for the DS number is “DSXXXXXXXXA”, where “XXXXXXXX” is the document number and “A” is the revision level of the document.

For the most up-to-date information on development tools, see the MPLAB® IDE online help. Select the Help menu, and then Topics to open a list of available online help files.

INTRODUCTION

This chapter contains general information that will be useful to know before using the MCP19215 Dual Boost/SEPIC Evaluation Board. Items discussed in this chapter include:

- Document Layout
- Conventions Used in this Guide
- Recommended Reading
- The Microchip Web Site
- Development Systems Customer Change Notification Service
- Customer Support
- Document Revision History

DOCUMENT LAYOUT

This document describes how to use the MCP19215 Dual Boost/SEPIC Evaluation Board as a development tool to emulate and debug firmware on a target board. The manual layout is as follows:

- **Chapter 1. “Product Overview”** – Includes a short overview of the MCP19215 device, and a general description of the MCP19215 Dual Boost/SEPIC Evaluation Board.
- **Chapter 2. “Installation and Operation”** – Includes instructions on how to get started with the MCP19215 Dual Boost/SEPIC Evaluation Board, a detailed description of the board, and the typical waveforms that are obtained from the board.
- **Appendix A. “Schematic and Layouts”** – Shows the schematic and layout diagrams for the MCP19215 Dual Boost/SEPIC Evaluation Board.
- **Appendix B. “Bill of Materials (BOM)”** – Lists the parts used to build the MCP19215 Dual Boost/SEPIC Evaluation Board.

MCP19215 Dual Boost/SEPIC Evaluation Board User's Guide

CONVENTIONS USED IN THIS GUIDE

This manual uses the following documentation conventions:

DOCUMENTATION CONVENTIONS

Description	Represents	Examples
Arial font:		
Italic characters	Referenced books	<i>MPLAB® IDE User's Guide</i>
	Emphasized text	...is the <i>only</i> compiler...
Initial caps	A window	the Output window
	A dialog	the Settings dialog
	A menu selection	select Enable Programmer
Quotes	A field name in a window or dialog	"Save project before build"
Underlined, italic text with right angle bracket	A menu path	<u><i>File>Save</i></u>
Bold characters	A dialog button	Click OK
	A tab	Click the Power tab
N'Rnnnn	A number in verilog format, where N is the total number of digits, R is the radix and n is a digit.	4'b0010, 2'hF1
Text in angle brackets < >	A key on the keyboard	Press <Enter>, <F1>
Courier New font:		
Plain Courier New	Sample source code	#define START
	Filenames	autoexec.bat
	File paths	c:\mcc18\h
	Keywords	_asm, _endasm, static
	Command-line options	-Opa+, -Opa-
	Bit values	0, 1
	Constants	0xFF, 'A'
Italic Courier New	A variable argument	<i>file.o</i> , where <i>file</i> can be any valid filename
Square brackets []	Optional arguments	mcc18 [options] <i>file</i> [options]
Curly brackets and pipe character: { }	Choice of mutually exclusive arguments; an OR selection	errorlevel {0 1}
Ellipses...	Replaces repeated text	var_name [, var_name...]
	Represents code supplied by user	void main (void) { ... }

RECOMMENDED READING

This user's guide describes how to use the MCP19215 Dual Boost/SEPIC Evaluation Board. Other useful documents are listed below. The following Microchip documents are available and recommended as supplemental reference resources:

- **MCP19214/5 – “Digitally-Enhanced Power Analog, Dual Channel, Low-Side PWM Controller” (DS20000000)** – This data sheet provides detailed information regarding the MCP19214/5 devices.
- **MCP19214/5 – Monitoring Graphical Interface User’s Guide (DS50000000)** – This User’s Guide includes information on how to install, understand, and use the monitoring and calibration tool for the MCP19214/5 devices.

THE MICROCHIP WEB SITE

Microchip provides online support via our web site at www.microchip.com. This web site is used as a means to make files and information easily available to customers. Accessible by using your favorite Internet browser, the web site contains the following information:

- **Product Support** – Data sheets and errata, application notes and sample programs, design resources, user’s guides and hardware support documents, latest software releases and archived software
- **General Technical Support** – Frequently Asked Questions (FAQs), technical support requests, online discussion groups, Microchip consultant program member listing
- **Business of Microchip** – Product selector and ordering guides, latest Microchip press releases, listing of seminars and events, listings of Microchip sales offices, distributors and factory representatives

DEVELOPMENT SYSTEMS CUSTOMER CHANGE NOTIFICATION SERVICE

Microchip’s customer notification service helps keep customers current on Microchip products. Subscribers will receive an e-mail notification whenever there are changes, updates, revisions or errata related to a specified product family or development tool of interest.

To register, access the Microchip web site at www.microchip.com, click on Customer Change Notification and follow the registration instructions.

The Development Systems product group categories are:

- **Compilers** – The latest information on Microchip C compilers, assemblers, linkers and other language tools. These include all MPLAB C compilers; all MPLAB assemblers (including MPASM assembler); all MPLAB linkers (including MPLINK object linker); and all MPLAB librarians (including MPLIB object librarian).
- **Emulators** – The latest information on Microchip in-circuit emulators. This includes the MPLAB REAL ICE™ and MPLAB ICE 2000 in-circuit emulators.
- **In-Circuit Debuggers** – The latest information on the Microchip in-circuit debuggers. This includes MPLAB ICD 3 in-circuit debuggers and PICkit 3 Debug Express.
- **MPLAB IDE** – The latest information on Microchip MPLAB IDE, the Windows Integrated Development Environment for development systems tools. This list is focused on the MPLAB IDE, MPLAB IDE Project Manager, MPLAB Editor and MPLAB SIM simulator, as well as general editing and debugging features.
- **Programmers** – The latest information on Microchip programmers. These include production programmers such as MPLAB REAL ICE in-circuit emulator, MPLAB ICD 3 in-circuit debugger and MPLAB PM3 device programmers. Also included

MCP19215 Dual Boost/SEPIC Evaluation Board User's Guide

are nonproduction development programmers such as PICSTART Plus and PICKit 2 and 3 programmers.

CUSTOMER SUPPORT

Users of Microchip products can receive assistance through several channels:

- Distributor or Representative
- Local Sales Office
- Field Application Engineer (FAE)
- Technical Support

Customers should contact their distributor, representative or field application engineer (FAE) for support. Local sales offices are also available to help customers. A listing of sales offices and locations is included in the back of this document.

Technical support is available through the web site at:
<http://www.microchip.com/support>.

DOCUMENT REVISION HISTORY

Revision A (March 2017)

- Initial Release of this Document.

Chapter 1. Product Overview

1.1 INTRODUCTION

This chapter provides an overview of the MCP19215 Dual Boost/SEPIC Evaluation Board and covers the following topics:

- [MCP19215 Device – Short Overview](#)
- [What is the MCP19215 Dual Boost/SEPIC Evaluation Board?](#)
- [What Does the MCP19215 Dual Boost/SEPIC Evaluation Board Kit Include?](#)

1.2 MCP19215 DEVICE – SHORT OVERVIEW

The MCP19215 is a highly integrated digitally-enhanced Pulse Width Modulation (PWM) controller used for low-side switch PWM applications such as battery chargers, bidirectional converters and LED lighting systems.

Since the MCP19215 uses traditional analog control circuitry to regulate the output of the DC/DC converter, the integration of the PIC[®] controller mid-range core is used to provide complete customization of device operating parameters, start-up and shut-down profiles, protection levels and fault handling procedures.

The MCP19215 is designed to efficiently operate from a single 4.5V-42V supply. It features integrated synchronous drivers, a bootstrap device, an internal linear regulator and 8K word nonvolatile memory, all in a space-saving 32-pin, 5 x 5 mm QFN package.

After initial device configuration by using Microchip's MPLAB[®] X Integrated Development Environment (IDE) software, I²C communication can be used by a host to communicate with or modify the operation of the MCP19215.

An internal 5V rail provides power to the PIC controller, and is also present on the V_{DD} pin. It is recommended that a 1 μF capacitor be placed between V_{DD} and P_{GND}. The V_{DD} pin may also be directly connected to the V_{DR} pin or connected through a low-pass RC filter. The V_{DR} pin provides power to the internal synchronous driver.

MCP19215 Dual Boost/SEPIC Evaluation Board User's Guide

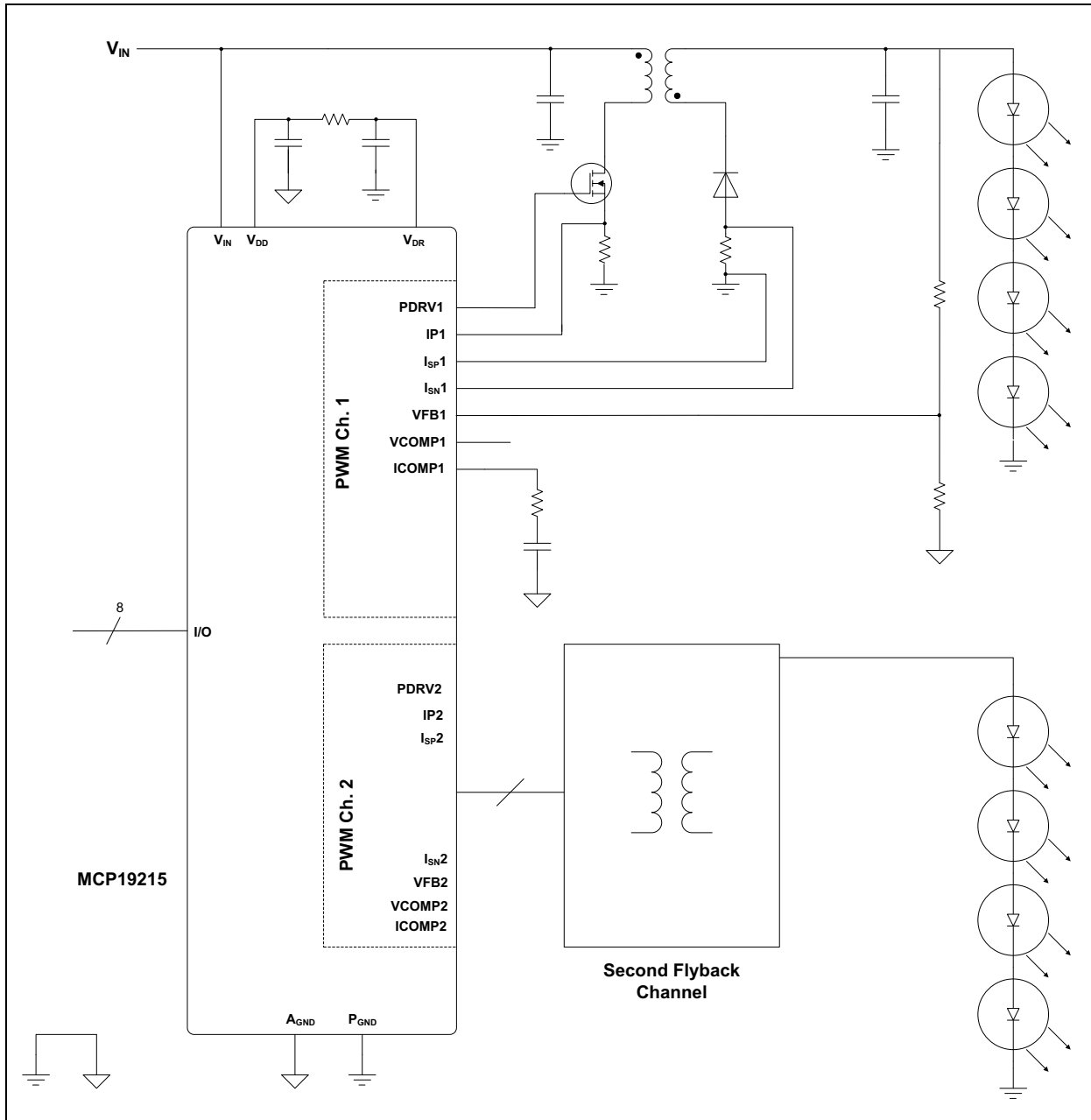

FIGURE 1-1: MCP19215 Typical Application Circuit.

1.3 WHAT IS THE MCP19215 DUAL BOOST/SEPIC EVALUATION BOARD?

The MCP19215 Dual Boost/SEPIC Evaluation Board demonstrates how the MCP19215 device operates in Boost and SEPIC topologies over a wide input voltage and load range. Nearly all operational and control system parameters are programmable by utilizing the integrated PIC controller.

For precise measurements of output current, a 0.1Ω shunt is used on each channel. Output current is measured using an internal op amp.

The Graphical User Interface (GUI) can be used to program the functioning parameters, and check operational status. To simplify the connection, a USB-to-I²C communication bridge is implemented on board, using the MCP2221-I/SL SOIC 14-Lead, allowing standard interface to any Microsoft® Windows® computer.

Alternatively, users can program the MCP19215 using their own firmware, further tailoring it to the application, using the MPLAB[®] X Integrated Development Environment (IDE) and a PICkit[™] 3 Programmer/Debugger on the J5 Header (see [Figure 2-1](#)).

The MCP19215 Dual Boost/SEPIC Evaluation Board board is equipped with headers for In-Circuit Serial Programming[™] (ICSP[™]), a mini-USB type B for communication, and test point pads on each GPIO pin.

The MCP19215 Dual Boost/SEPIC Evaluation Board is also intended to demonstrate an optimized Printed Circuit Board (PCB) layout that minimizes parasitic noise while increasing efficiency and power density. Proper PCB layout is critical to achieve optimum MCP19215 operation, as well as power train efficiency and noise minimization.

The MPLAB X (IDE), the MCP19215 monitoring graphical user interface, and example firmware are available for download from the Microchip web site, at www.microchip.com.

1.4 WHAT DOES THE MCP19215 DUAL BOOST/SEPIC EVALUATION BOARD KIT INCLUDE?

This MCP19215 Dual Boost/SEPIC Evaluation Board kit includes:

- The MCP19215 Dual Boost/SEPIC Evaluation Board (ADM00799)
- USB A to Mini-USB Type B Cable
- Important Information Sheet

MCP19215 Dual Boost/SEPIC Evaluation Board User's Guide

NOTES:

Chapter 2. Installation and Operation

2.1 INTRODUCTION

This chapter provides a detailed description of the MCP19215 Dual Boost/SEPIC Evaluation Board, instructions on how to begin using the board, and lists the typical waveforms obtained from the board.

The chapter is laid out as follows:

- [MCP19215 Dual Boost/SEPIC Evaluation Board Features](#)
- [Getting Started](#)
- [Setup Procedure](#)
- [Operating the MCP19215 Dual Boost/SEPIC Evaluation Board](#)
- [Typical Performance Data and Waveforms](#)

2.2 MCP19215 DUAL BOOST/SEPIC EVALUATION BOARD FEATURES

The MCP19215 Dual Boost/SEPIC Evaluation Board was developed to provide a compact, low-cost and highly-efficient DC/DC conversion for low-to-medium output currents.

The key features of the MCP19215 Dual Boost/SEPIC Evaluation Board include:

- input voltage range: 8V-5V
- output voltage: 20V for both channels (can be software adjusted from input voltage + 1V-4V for channel 1, and 9V-24V for channel 2)
- maximum output current: 1A (can be software adjusted from 0A to 1A; the board default setting is 0.2A)
- 300 kHz switching frequency (can be software adjusted from 100 kHz to 2 MHz)
- on-board high performance power MOSFET transistors
- overcurrent and overvoltage protection
- status report (including errors, input voltage, output voltage and current) via I²C communication
- under voltage lockout (UVLO) with programmable thresholds (via software)

2.3 GETTING STARTED

The MCP19215 Dual Boost/SEPIC Evaluation Board is fully assembled and tested to evaluate and demonstrate the MCP19215 device capabilities.

2.3.1 Necessary Instruments and Tools Required for Operation

- Adjustable DC power supply with 0V-5V/2 A_{DC} range output capability
- Electronic load with at least 2A current capability and load stepping capability
- Digital oscilloscope with a minimum bandwidth of 50 MHz
- Digital voltmeter/ammeter
- Wires for connections; these wires must sustain high currents:
 - 4A for the connection between the adjustable DC power supply and board
 - 2A for the connection between the board and the electronic load

MCP19215 Dual Boost/SEPIC Evaluation Board User's Guide

2.4 SETUP PROCEDURE

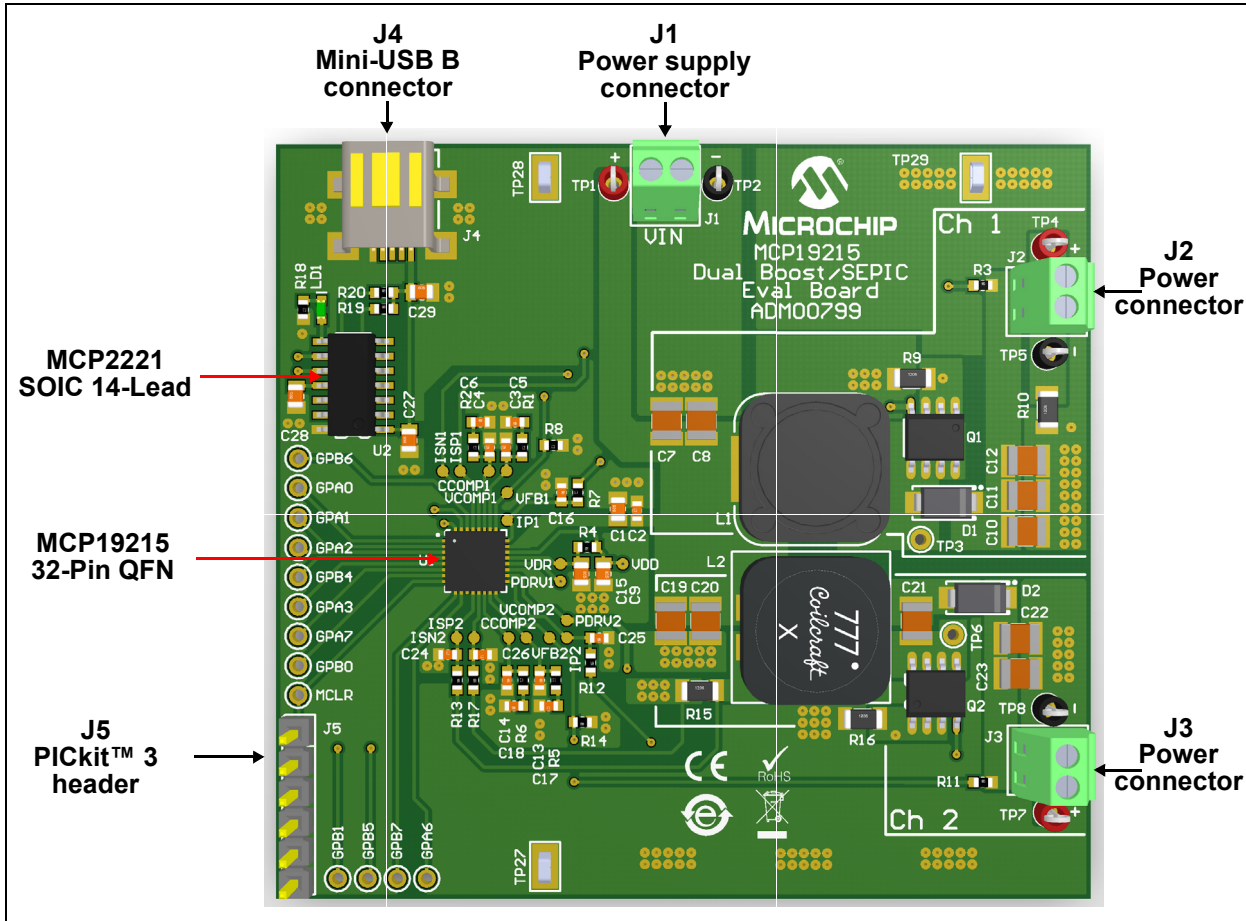

FIGURE 2-1: MCP19215 Dual Boost/SEPIC Evaluation Board – Top View.

To power up the MCP19215 Dual Boost/SEPIC Evaluation Board, the following steps must be completed:

1. connect the electronic load to the J2 and/or J3 connector on the board by observing the polarity; the positive (+) and negative (-) connector pins are marked on the board silkscreen (refer to [Figure 2-1](#)).
2. connect the adjustable DC power supply to the J1 connector on the board by matching the polarity to the positive (+) and negative (-) connector pins marked on the board silkscreen (refer to [Figure 2-1](#)).
3. set the DC voltage supplied by the adjustable DC power supply to 12V.

- connect the board to a PC (on which the MCP19214/5 Monitoring GUI is installed) via the USB-A to mini-USB type B cable supplied, by using the J4 connector on the board.

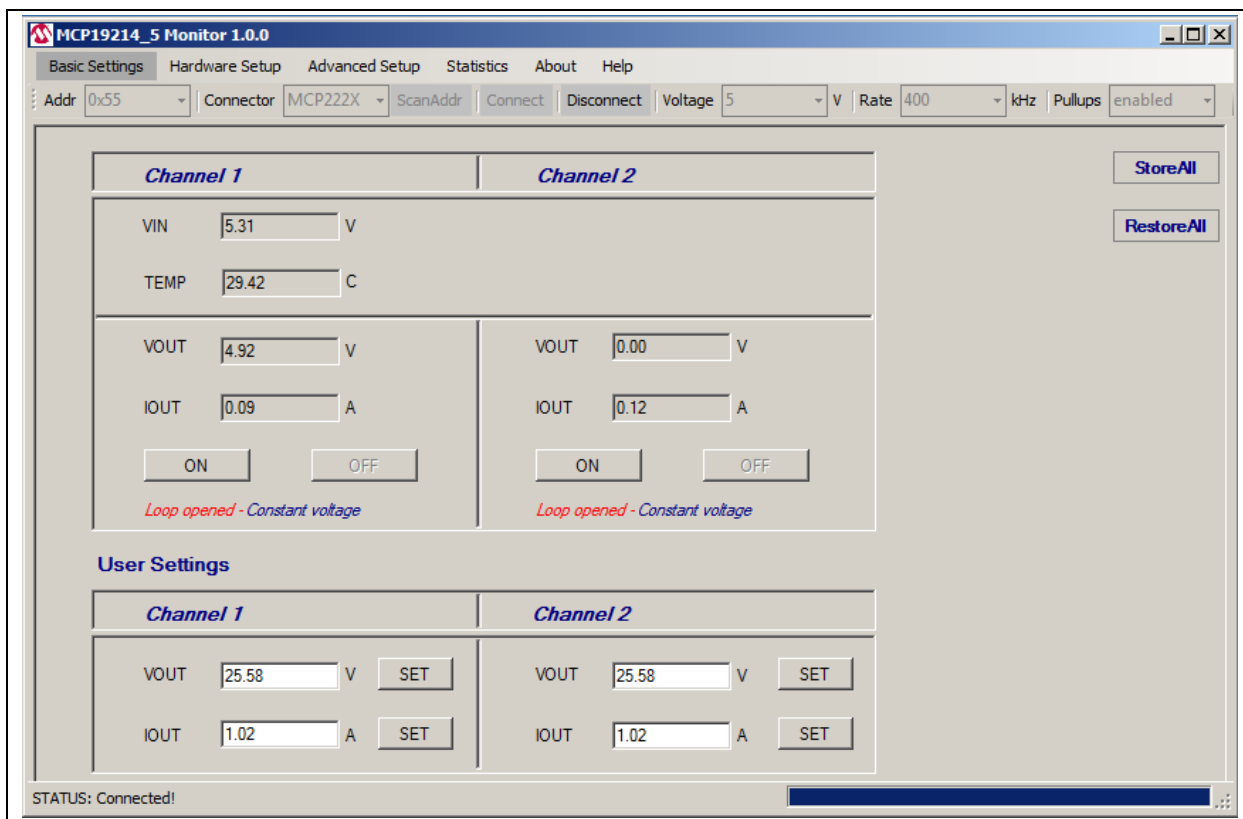

FIGURE 2-2: MCP19214/5 Monitoring GUI.

- after powering up, the output voltage is automatically enabled on for both channels. Alternatively, the output voltage may be enabled or disabled individually for each channel by using the GUI ON and OFF buttons.
- the board is factory set to deliver 20V at 1A maximum, with the loop adjusted for optimum performance, and current measurement performed via the internal op amp.
If different settings are desired, changes may be performed in two ways:
 - via the I²C-to-USB on-board interface. Refer to the MCP19214/5 Monitoring GUI User Guide for details.
 - by the user's own software that can be loaded into the MCP19215 by connecting J5 on the board to a PICKIT™3 or another suitable programming tool (see [Figure 2-1](#)).

MCP19215 Dual Boost/SEPIC Evaluation Board User's Guide

2.5 OPERATING THE MCP19215 DUAL BOOST/SEPIC EVALUATION BOARD

Figure 2-3 shows the board typical test setup.

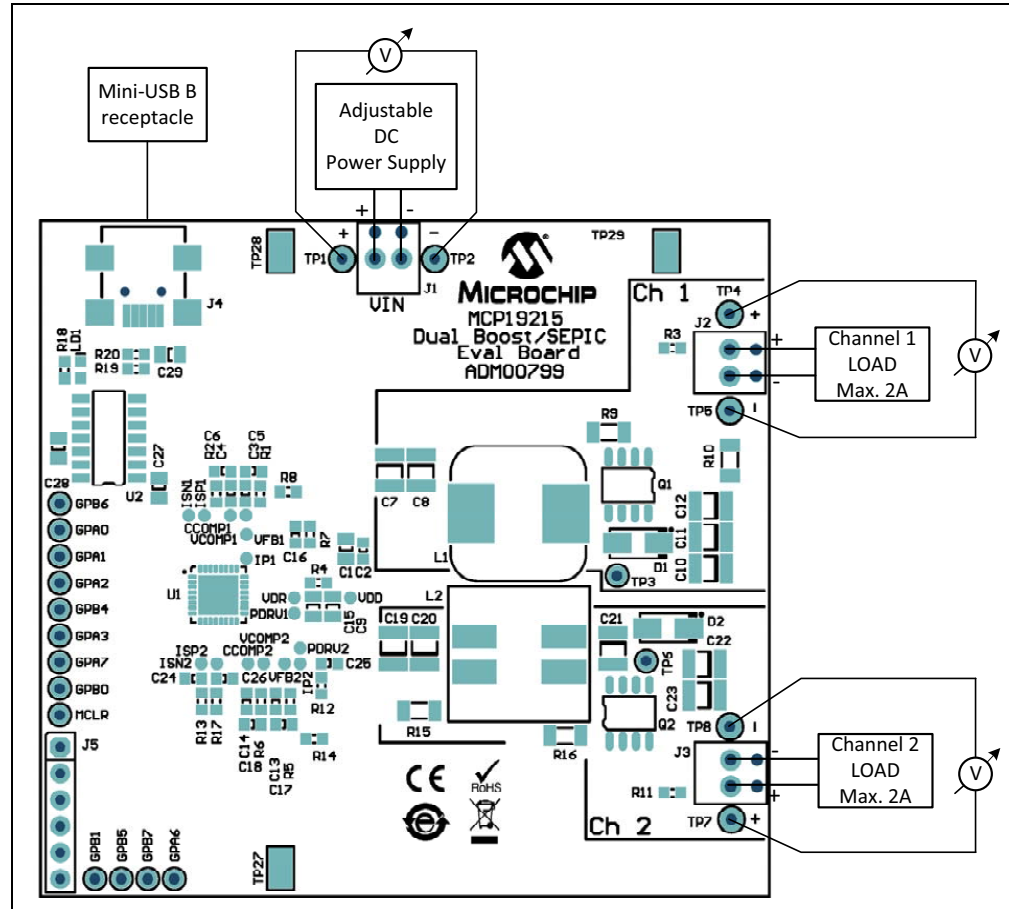

FIGURE 2-3: MCP19215 Dual Boost/SEPIC Evaluation Board – Typical Test Setup.

Table 2-1 lists all the available test points on the board.

The user can connect various instruments to the listed test points to evaluate the parameters of the converter. The typical performance data, curves and waveforms are presented in [Section 2.6](#).

TABLE 2-1: TEST POINTS DESCRIPTION

Label	Function	Description
TP1_GND TP2_GND TP3_GND	GND	Power GND
TP1	$V_{IN (+)}$	Input Voltage (+)
TP2	$V_{IN (-)}$	Input Voltage (-)
TP3	SW1	Switching Node for Channel 1
TP4	$V_{OUT1 (+)}$	Output Voltage (+) for Channel 1
TP5	$V_{OUT1 (-)}$	Output Voltage (-) for Channel 1
TP6	SW2	Switching Node for Channel 2
TP7	$V_{OUT2 (+)}$	Output Voltage (+) for Channel 2

Note 1: Refer to the MCP19214/5 data sheet, for a detailed description of the port pin functions.

TABLE 2-1: TEST POINTS DESCRIPTION (CONTINUED)

Label	Function	Description
TP8	$V_{OUT2(-)}$	Output Voltage (-) for Channel 2
PDRV1	PDRV1	Driver Signal for Channel 1
ISN1	I_{SN1}	Output Current Sense Measurement (-) for Channel 1
ISP1	I_{SP1}	Output Current Sense Current Measurement (+) for Channel 1
CCOMP1	CCOMP1	Current Loop Compensation Circuitry for Channel 1
VCOMP1	VCOMP1	Voltage Loop Compensation Circuitry for Channel 1
VFB1	VFB1	Voltage Feedback for Channel 1
IP1	IP1	Primary Inductor Current Sense Input for Channel 1
PDRV2	PDRV2	Driver Signal for Channel 2
ISN2	I_{SN2}	Output Current Sense Measurement (-) for Channel 2
ISP2	I_{SP2}	Output Current Sense Current Measurement (+) for Channel 2
CCOMP2	CCOMP2	Current Loop Compensation Circuitry for Channel 2
VCOMP2	VCOMP2	Voltage Loop Compensation Circuitry for Channel 2
VFB2	VFB2	Voltage Feedback for Channel 2
IP2	IP2	Primary Inductor Current Sense Input for Channel 2
VDD	V_{DD}	Linear Regulator Output (5V)
VDR	V_{DR}	Input for Driver Supply (5V)
MCLR	MCLR (1)	—
GPA0	GPA0 (1)	GPA0 or Analog Test Output
GPA1	GPA1 (1)	—
GPA2	GPA2 (1)	—
GPA3	GPA3 (1)	—
GPA6	GPA6 (1)	—
GPA7	GPA7 (1)	Clock Signal for I ² C
GPB0	GPB0 (1)	Data Signal for I ² C
GPB1	GPB1 (1)	—
GPB4	GPB4 (1)	Data Signal for ICSP™
GPB5	GPB5 (1)	Clock Signal for ICSP
GPB6	GPB6 (1)	—
GPB7	GPB7 (1)	—

Note 1: Refer to the MCP19214/5 data sheet, for a detailed description of the port pin functions.

MCP19215 Dual Boost/SEPIC Evaluation Board User's Guide

2.6 TYPICAL PERFORMANCE DATA AND WAVEFORMS

Table 2-2 describes the converter parameters.

TABLE 2-2: MCP19215 CONVERTER PARAMETERS

Parameter	Value	Comments
Input Voltage Range (V)	8 – 15	—
Output Voltage (V)	18	± 2.5% tolerance
Maximum Output Current (A)	0.75	Steady state output current
Channel 1 Output Voltage Ripple (mV)	< 100	$V_{IN} = 12V, I_{OUT} = 250\text{ mA}$
Channel 2 Output Voltage Ripple (mV)	< 200	$V_{IN} = 12V, I_{OUT} = 500\text{ mA}$
Input Voltage Ripple (mV)	< 50	$V_{IN} = 12V, I_{OUT} = 750\text{ mA}$
Switching Frequency (kHz)	305 kHz (typical)	—

Figure 2-4 through 2-9 show the typical waveforms that are obtained from the evaluation board.

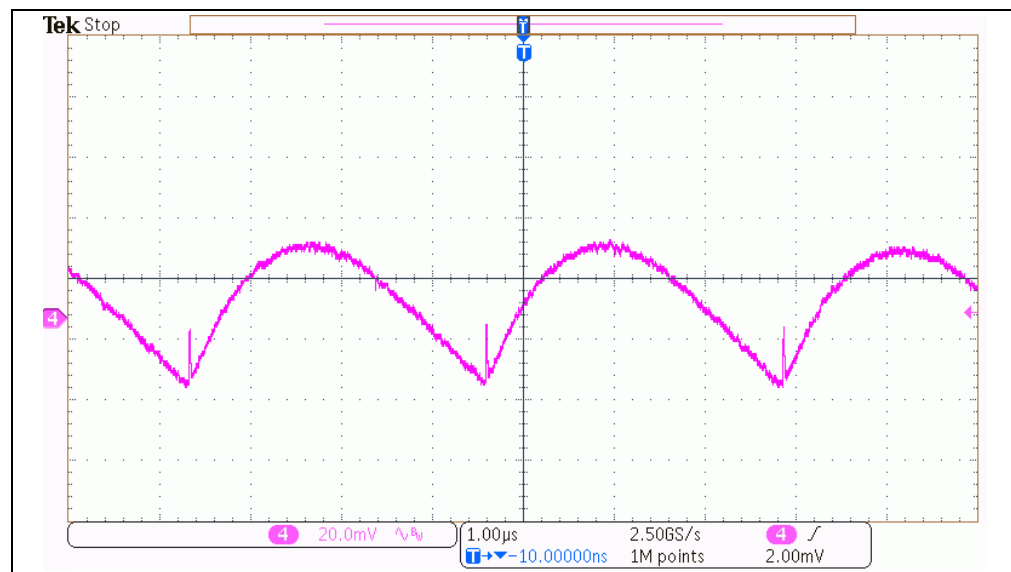

FIGURE 2-4: Output Voltage Ripple/Noise Channel 1 ($V_{IN} = 12V$, $I_{OUT1} = 250\text{ mA}$, $BW = 20\text{ MHz}$).

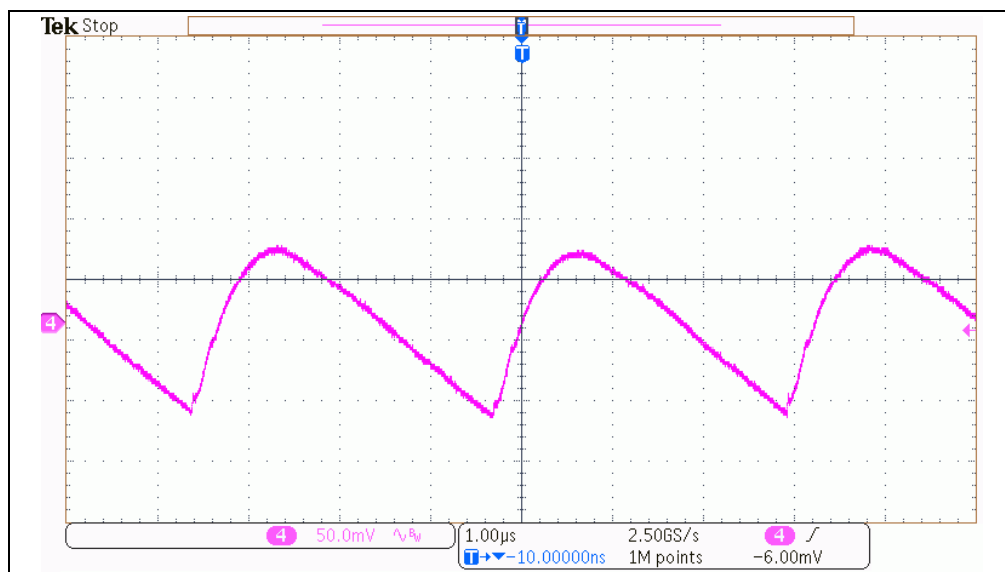

FIGURE 2-5: Output Voltage Ripple/Noise Channel 2 ($V_{IN} = 12V$, $I_{OUT2} = 500\text{ mA}$, $BW = 20\text{ MHz}$).

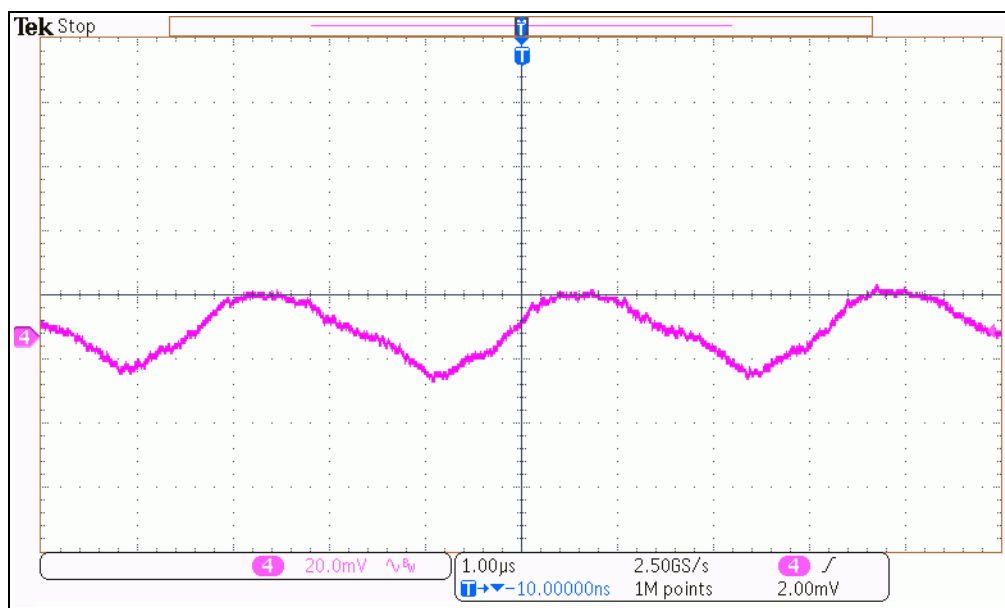

FIGURE 2-6: Input Voltage Ripple/Noise ($V_{IN} = 12V$, $I_{OUT} = 750\text{ mA}$, $BW = 20\text{ MHz}$).

MCP19215 Dual Boost/SEPIC Evaluation Board User's Guide

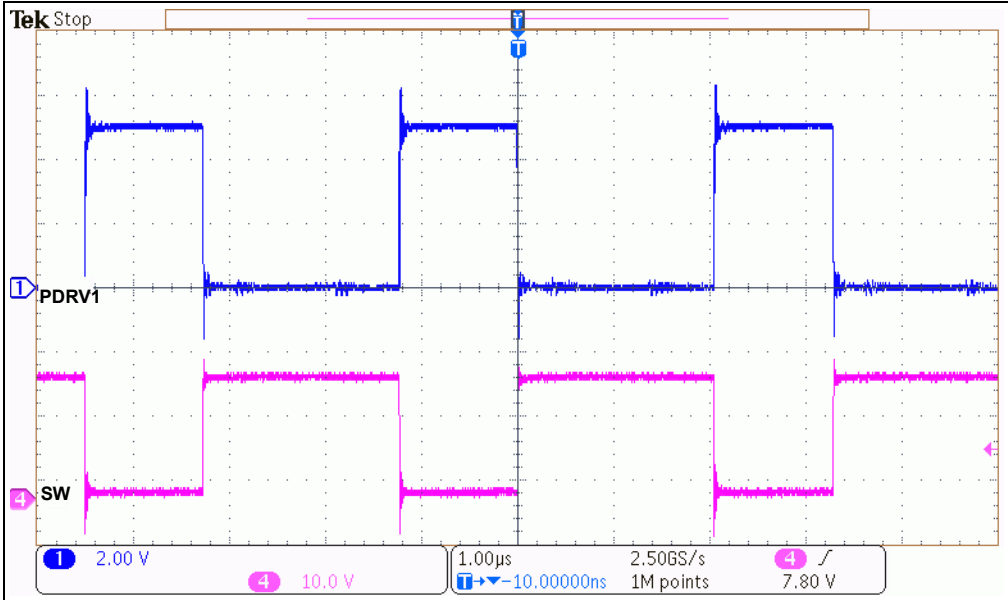

FIGURE 2-7: SW1, PDRV1 Signals ($V_{IN} = 12V$, $I_{OUT1} = 250\text{ mA}$, $BW = 300\text{ MHz}$).

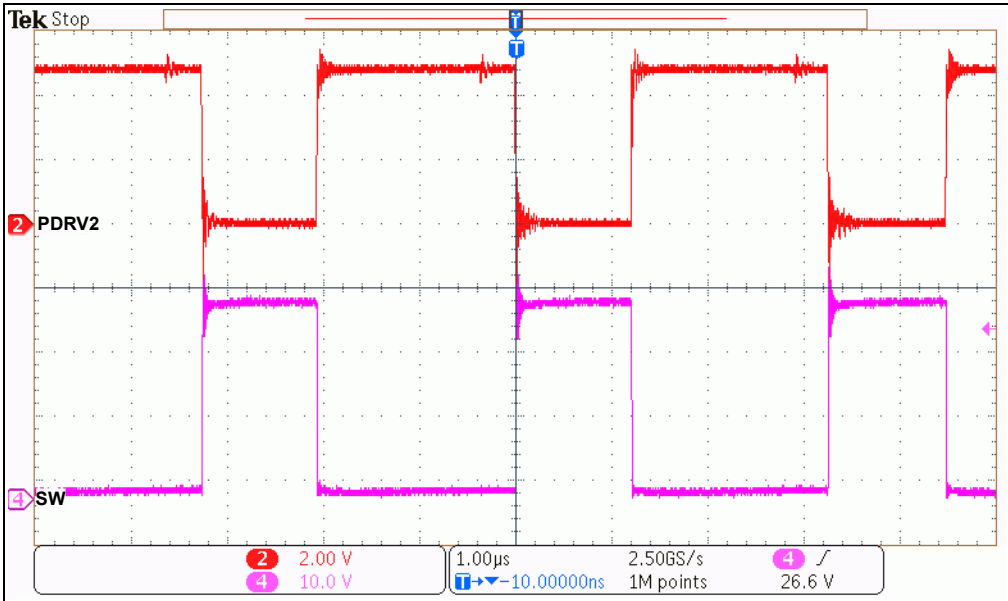

FIGURE 2-8: SW2, PDRV2 Signals ($V_{IN} = 12V$, $I_{OUT2} = 500\text{ mA}$, $BW = 300\text{ MHz}$).

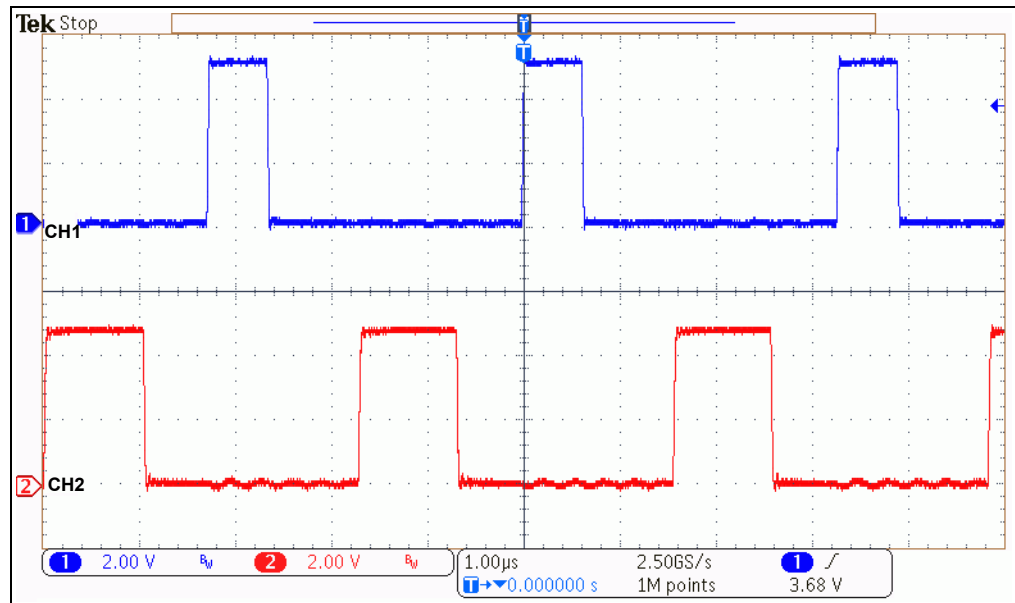

FIGURE 2-9: LDRV and HDRV Signals ($V_{IN} = 12V$, $I_{OUT} = 15A$, $BW = 300\text{ MHz}$).

MCP19215 Dual Boost/SEPIC Evaluation Board User's Guide

NOTES:



MCP19215 DUAL BOOST/SEPIC EVALUATION BOARD USER'S GUIDE

Appendix A. Schematic and Layouts

A.1 INTRODUCTION

This appendix contains the following schematics and layouts for the MCP19215 Dual Boost/SEPIC Evaluation Board (ADM00799):

- [Board – Schematic](#)
- [Board – Top Silk](#)
- [Board – Top Copper and Silk](#)
- [Board – Top Copper](#)
- [Board – Bottom Copper](#)
- [Board – Bottom Copper and Silk](#)
- [Board – Bottom Silk](#)

A.3 BOARD – TOP SILK

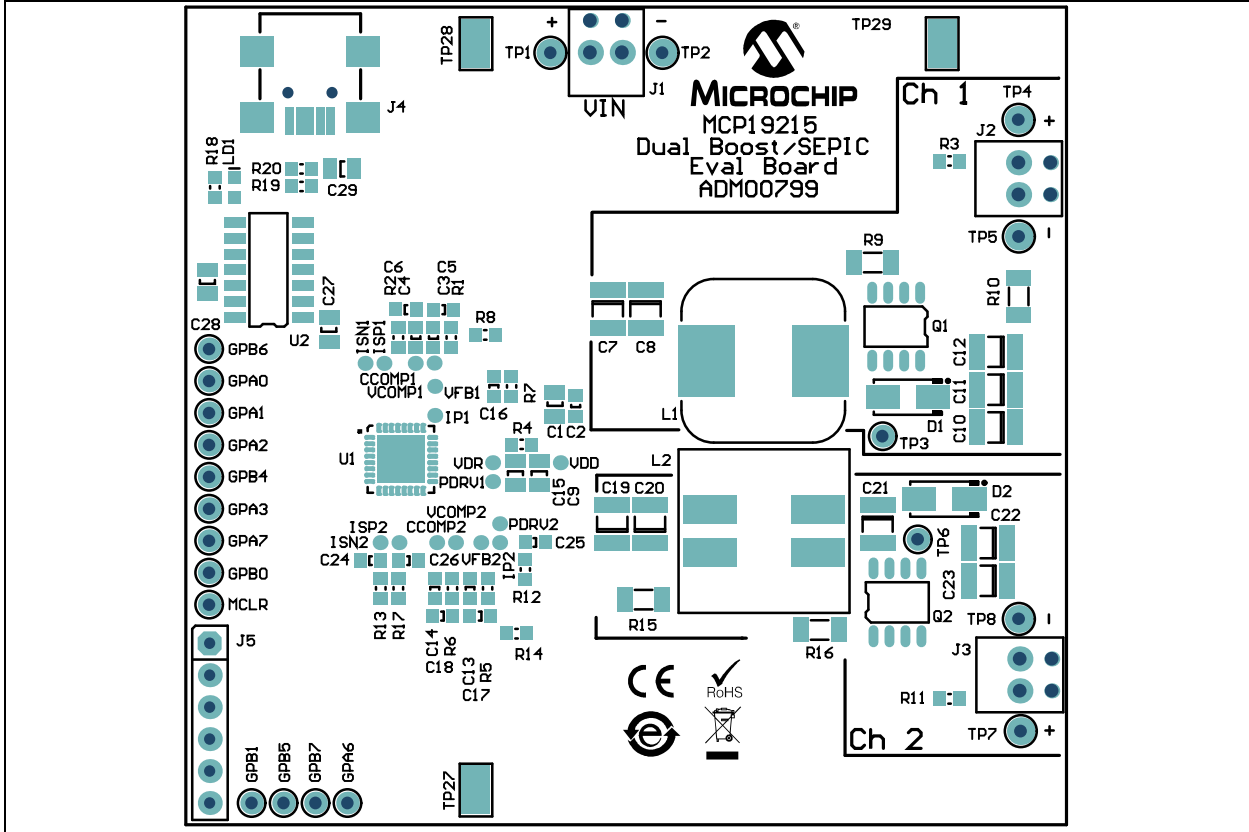

A.4 BOARD – TOP COPPER AND SILK

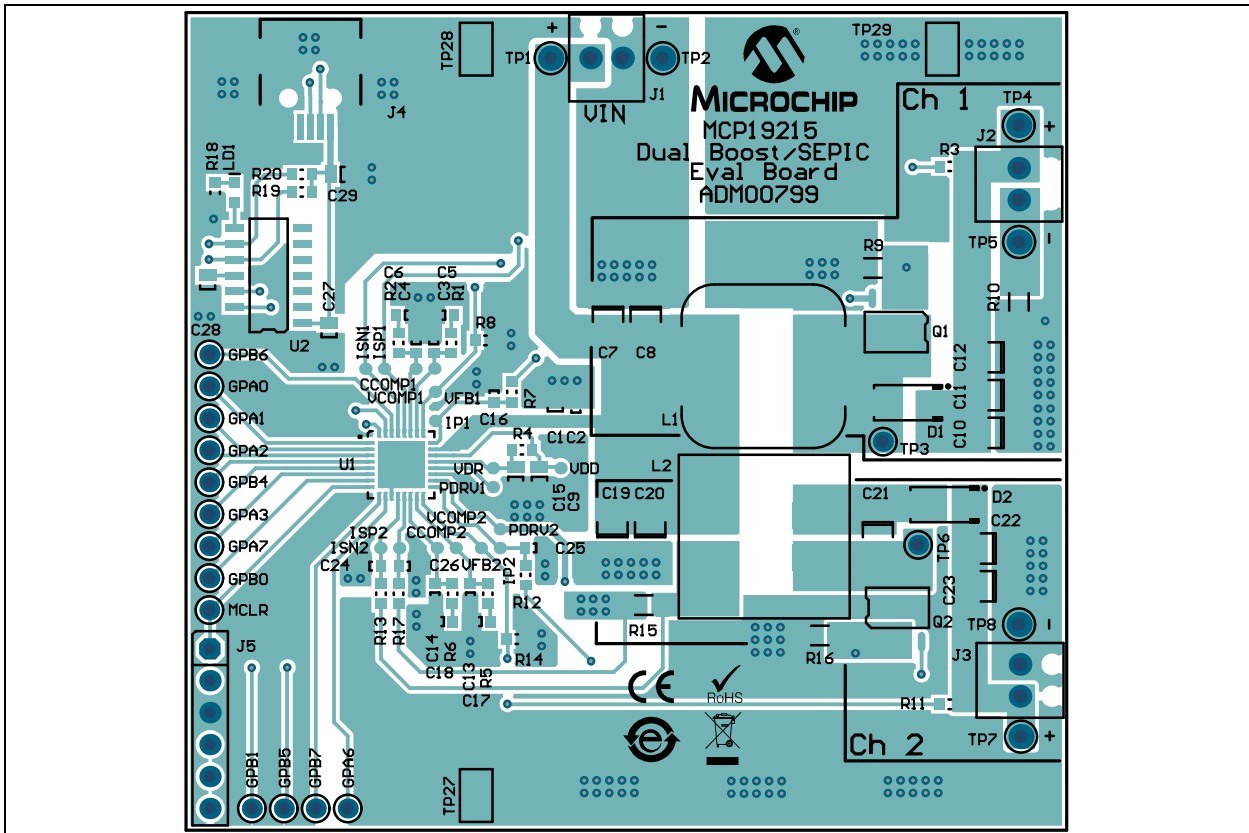

MCP19215 Dual Boost/SEPIC Evaluation Board User's Guide

A.5 BOARD – TOP COPPER

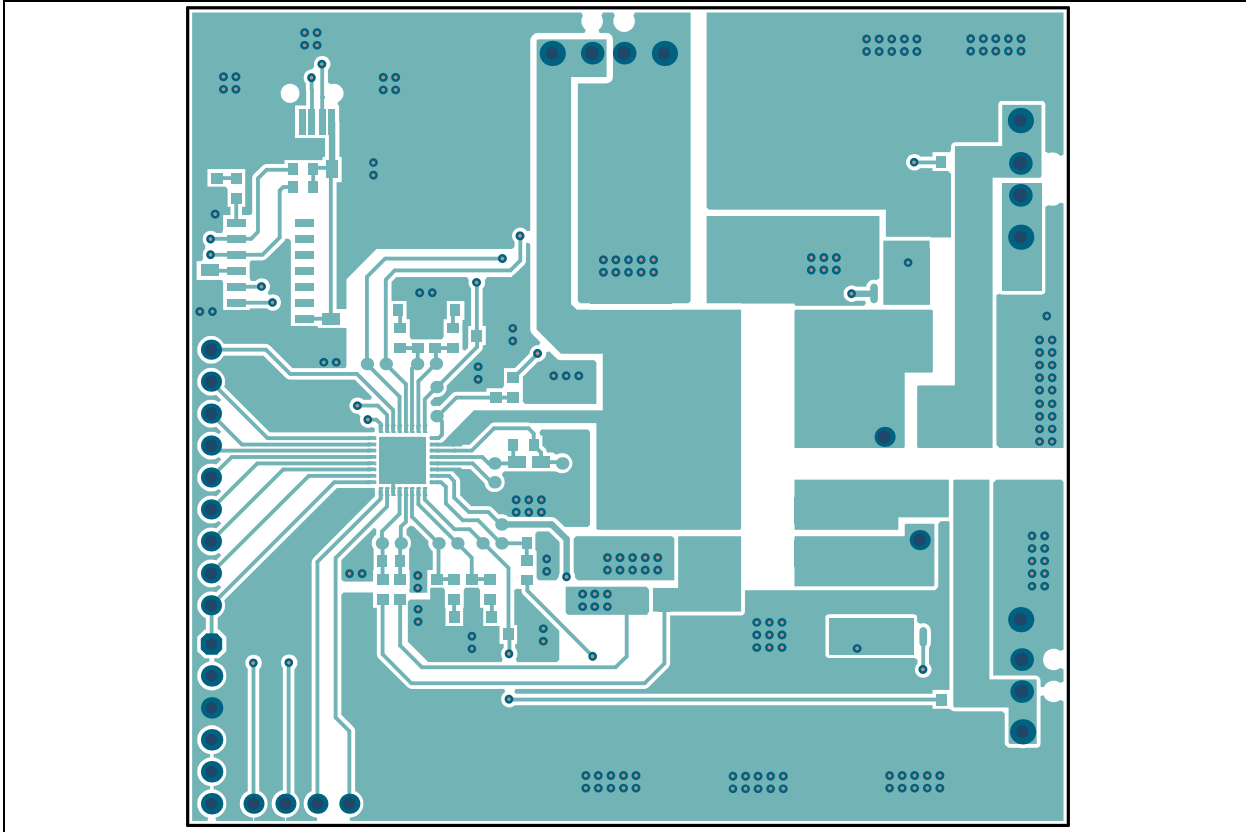

A.6 BOARD – BOTTOM COPPER

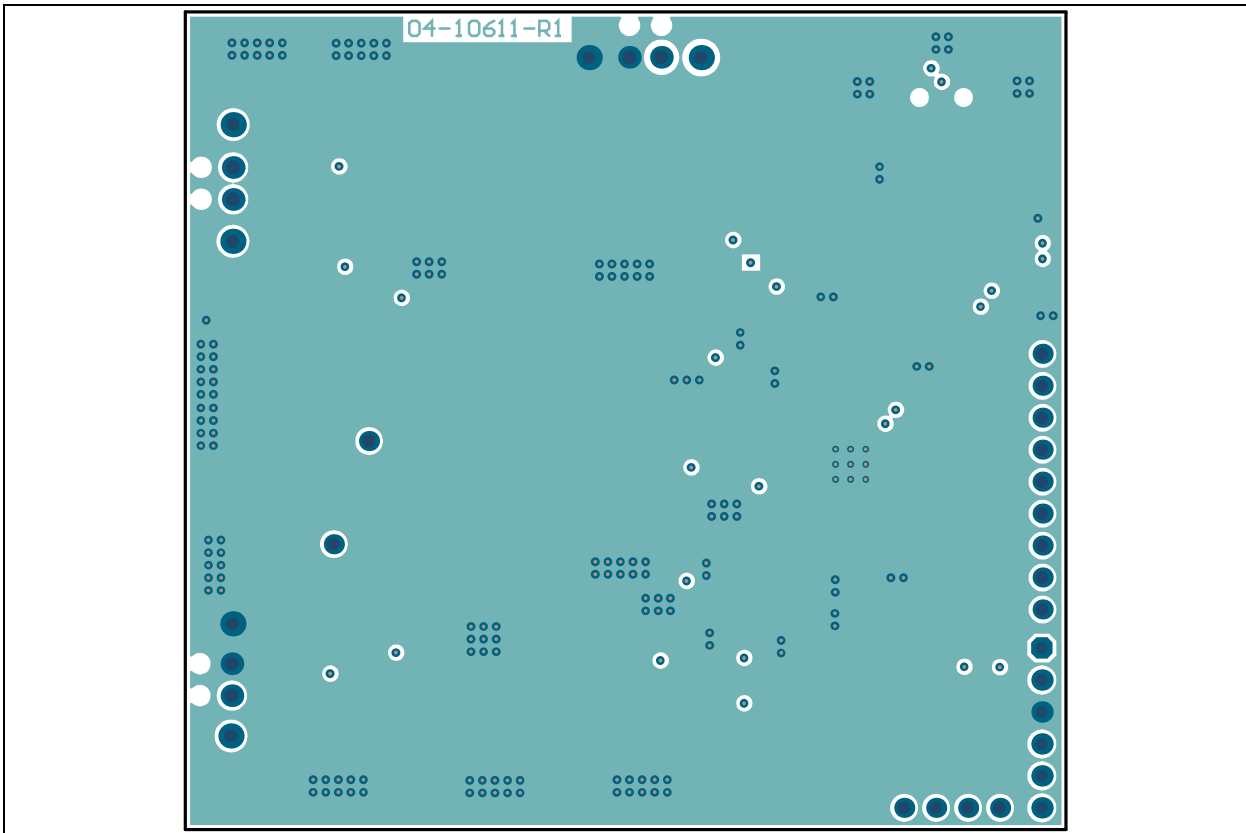

A.7 BOARD – BOTTOM COPPER AND SILK

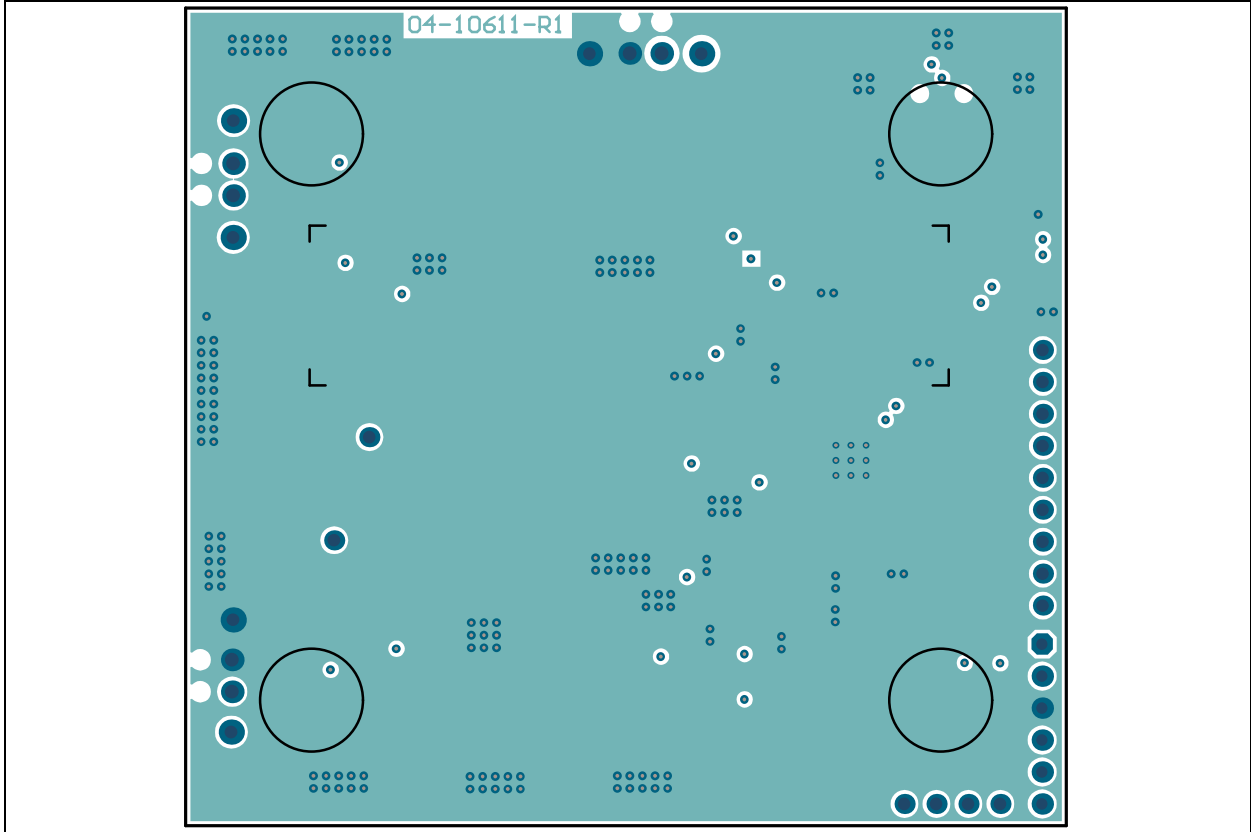

A.8 BOARD – BOTTOM SILK

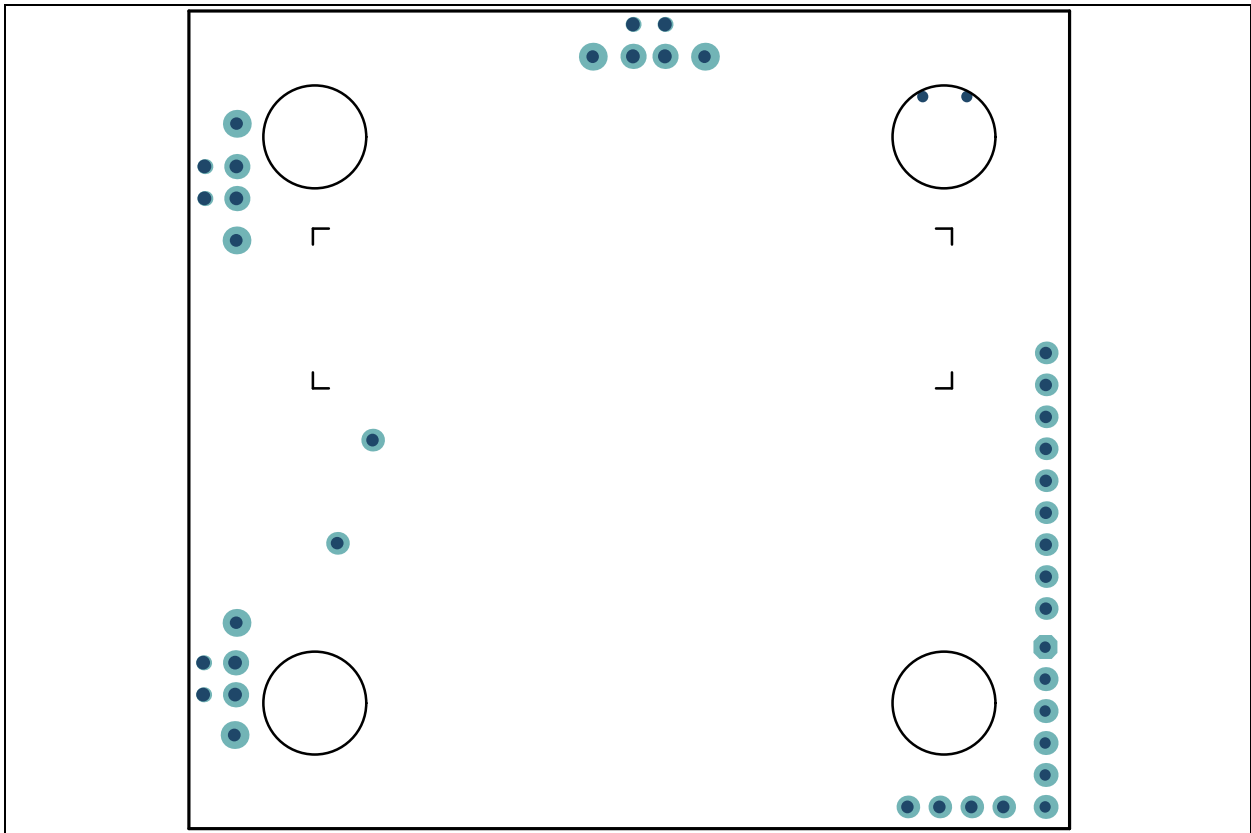

MCP19215 Dual Boost/SEPIC Evaluation Board User's Guide

NOTES:

Appendix B. Bill of Materials (BOM)

**TABLE B-1: MCP19215 DUAL BOOST/SEPIC EVALUATION BOARD (ADM00799)
BILL OF MATERIALS (Note 1)**

Qty.	Reference	Description	Manufacturer	Part Number
5	C1, C15 C27-C29	1 μ F 50V Ceramic Capacitor X7R 0805 (2012 Metric) 0.079" L x 0.049" W (2.00 mm x 1.25 mm)	Murata Electronics, Inc.	GRM21BR71H105KA12L
1	C2	0.10 μ F 50V Ceramic Capacitor X7R 0603 (1608 Metric) 0.063" L x 0.031" W (1.60 mm x 0.80 mm)	Murata Electronics, Inc.	GRM188R71H104KA93D
4	C3, C4 C13, C14	82 pF 50V Ceramic Capacitor C0G, NP0 0603 (1608 Metric) 0.063" L x 0.031" W (1.60 mm x 0.80 mm)	Murata Electronics, Inc.	GRM1885C1H820JA01D
4	C5, C6 C17, C18	4700 pF 50V Ceramic Capacitor X7R 0603 (1608 Metric) 0.063" L x 0.031" W (1.60 mm x 0.80 mm)	KEMET	C0603C472K5RACTU
9	C7, C8 C10-C12 C19, C20 C22, C23	10 μ F 50V Ceramic Capacitor X7R 1210 (3225 Metric) 0.126" L x 0.098" W (3.20 mm x 2.50 mm)	TDK Corporation	C3225X7R1H106M250AC
1	C9	4.7 μ F 25V Ceramic Capacitor X7R 0805 (2012 Metric) 0.079" L x 0.049" W (2.00 mm x 1.25 mm)	TDK Corporation	C2012X7R1E475K125AB
2	C16, C25	27 pF 50V Ceramic Capacitor C0G, NP0 0603 (1608 Metric) 0.063" L x 0.031" W (1.60 mm x 0.80 mm)	KEMET	C0603C270J5GACTU
1	C21	2.2 μ F 100V Ceramic Capacitor X7R 1210 (3225 Metric) 0.126" L x 0.098" W (3.20 mm x 2.50 mm)	KEMET	C1210C225K1RACTU
2	C24, C26	2200 pF 50V Ceramic Capacitor X7R 0603 (1608 Metric) 0.063" L x 0.031" W (1.60 mm x 0.80 mm)	KEMET	C0603C222K5RACTU
2	D1, D2	Diode Schottky 40V 2A Surface Mount DO-214AC (SMA)	Vishay/Dale	SS24S-E3/61T
3	J1-J3	2 Position Wire-to-Board Terminal Block Horizontal with Board 0.100" (2.54 mm) Through Hole	PHOENIX CONTACT	1725656
1	J4	Connector USB 2.0 Mini-B Female SMD R/A	Hirose Electric Co., Ltd.	UX60-MB-5ST
1	J5	6 Positions Header, Unshrouded Connector 0.100" (2.54 mm) Through Hole Gold or Gold, GXT™	Amphenol Commercial	68001-106HLF
1	L1	Surface Mount Power Inductor 10 μ H 4A 20% SMD L12.3W12.3H6	Coilcraft	MSS1260-103MLD

Note 1: The components listed in this Bill of Materials are representative of the PCB assembly. The released BOM used in manufacturing uses all RoHS-compliant components.

MCP19215 Dual Boost/SEPIC Evaluation Board User's Guide

**TABLE B-1: MCP19215 DUAL BOOST/SEPIC EVALUATION BOARD (ADM00799)
BILL OF MATERIALS (Note 1) (CONTINUED)**

Qty.	Reference	Description	Manufacturer	Part Number
1	L2	Shielded Coupled Power Inductor 4.7 μ H 3.16A 20% SMD L12.3W12.3H6	Coilcraft	MSD1260-472MLB
1	LD1	Green 571nm LED Indication - Discrete 2V 0603 (1608 Metric)	Lite-On®, Inc.	LTST-C191KGKT
2	Q1, Q2	MOSFET N-CH 60V 6A 8-SOIC	Vishay Siliconix	SI4850EY-T1-E3
4	PAD1-PAD4	Bumper Cylindrical, Tapered 0.312" Dia (7.92 mm) Polyurethane Black	3M	SJ61A11
1	PCB	MCP19215 Dual Boost/SEPIC Evalua- tion Board – Printed Circuit Board	—	04-10611
4	R1, R2 R5, R6	RES SMD 220 OHM 5% 1/10W 0603	ROHM Semiconductor	MCR03EZPJ221
2	R3, R11	RES TKF 150k 1% 1/8W SMD 0603	KOA Speer Electronics, Inc.	SG73S1JTDD1503F
1	R4	RES SMD 3.3 OHM 1% 1/10W 0603	Panasonic - ECG	ERJ-3RQF3R3V
2	R7, R12	RES SMD 100 OHM 5% 1/10W 0603	Vishay/Dale	CRCW0603100RJNEA
2	R8, R14	RES SMD 13K OHM 1% 1/10W 0603	Panasonic - ECG	ERJ-3EKF1302V
4	R9, R10 R15, R16	RES TKF 0.1R 1% 1/2W SMD 1206	Bourns®, Inc.	CRM1206-FX-R100ELF
2	R13, R17	RES SMD 680 OHM 1% 1/10W 0603	Panasonic - ECG	ERJ-3EKF6800V
1	R18	RES SMD 820 OHM 5% 1/10W 0603	Panasonic - ECG	ERJ-3GEYJ821V
2	R19, R20	RES SMD 4.7K OHM 5% 1/10W 0603	Panasonic - ECG	ERJ-3GEYJ472V
3	TP1, TP4 TP7	Red PC Test Point, Miniature 0.100" Dia x 0.180" L (2.54 mm x 4.57 mm) Phos- phor Bronze, Silver Plating 0.040" (1.02 mm) Hole Diameter Mounting Type	Keystone Electronics Corp.	5000
3	TP2, TP5 TP8	Black PC Test Point, Miniature 0.100" Dia x 0.180" L (2.54 mm x 4.57 mm) Phosphor Bronze, Silver Plating 0.040" (1.02 mm) Hole Diameter Mounting Type	Keystone Electronics Corp.	5001
3	TP27-TP29	Natural PC Test Point 0.128" x 0.065" x 0.079" (3.25 mm x 1.65 mm x 2.00 mm) Brass, Tin Plating Surface-Mount Mount- ing Type	Harwin Plc.	S1751-46R
1	U1	Analog Dual PWM Controller 2 MHz MCP19215-E/S8 QFN-32	Microchip Technology, Inc.	MCP19215-E/S8
1	U2	Interface USB I ² C/UART MCP2221-I/SL SOIC-14	Microchip Technology, Inc.	MCP2221-I/SL

Note 1: The components listed in this Bill of Materials are representative of the PCB assembly. The released BOM used in manufacturing uses all RoHS-compliant components.



MICROCHIP

Worldwide Sales and Service

AMERICAS

Corporate Office
2355 West Chandler Blvd.
Chandler, AZ 85224-6199
Tel: 480-792-7200
Fax: 480-792-7277
Technical Support:
<http://www.microchip.com/support>
Web Address:
www.microchip.com

Atlanta
Duluth, GA
Tel: 678-957-9614
Fax: 678-957-1455

Austin, TX
Tel: 512-257-3370

Boston
Westborough, MA
Tel: 774-760-0087
Fax: 774-760-0088

Chicago
Itasca, IL
Tel: 630-285-0071
Fax: 630-285-0075

Dallas
Addison, TX
Tel: 972-818-7423
Fax: 972-818-2924

Detroit
Novi, MI
Tel: 248-848-4000

Houston, TX
Tel: 281-894-5983

Indianapolis
Noblesville, IN
Tel: 317-773-8323
Fax: 317-773-5453
Tel: 317-536-2380

Los Angeles
Mission Viejo, CA
Tel: 949-462-9523
Fax: 949-462-9608
Tel: 951-273-7800

Raleigh, NC
Tel: 919-844-7510

New York, NY
Tel: 631-435-6000

San Jose, CA
Tel: 408-735-9110
Tel: 408-436-4270

Canada - Toronto
Tel: 905-695-1980
Fax: 905-695-2078

ASIA/PACIFIC

Asia Pacific Office
Suites 3707-14, 37th Floor
Tower 6, The Gateway
Harbour City, Kowloon

Hong Kong
Tel: 852-2943-5100
Fax: 852-2401-3431

Australia - Sydney
Tel: 61-2-9868-6733
Fax: 61-2-9868-6755

China - Beijing
Tel: 86-10-8569-7000
Fax: 86-10-8528-2104

China - Chengdu
Tel: 86-28-8665-5511
Fax: 86-28-8665-7889

China - Chongqing
Tel: 86-23-8980-9588
Fax: 86-23-8980-9500

China - Dongguan
Tel: 86-769-8702-9880

China - Guangzhou
Tel: 86-20-8755-8029

China - Hangzhou
Tel: 86-571-8792-8115
Fax: 86-571-8792-8116

China - Hong Kong SAR
Tel: 852-2943-5100
Fax: 852-2401-3431

China - Nanjing
Tel: 86-25-8473-2460
Fax: 86-25-8473-2470

China - Qingdao
Tel: 86-532-8502-7355
Fax: 86-532-8502-7205

China - Shanghai
Tel: 86-21-3326-8000
Fax: 86-21-3326-8021

China - Shenyang
Tel: 86-24-2334-2829
Fax: 86-24-2334-2393

China - Shenzhen
Tel: 86-755-8864-2200
Fax: 86-755-8203-1760

China - Wuhan
Tel: 86-27-5980-5300
Fax: 86-27-5980-5118

China - Xian
Tel: 86-29-8833-7252
Fax: 86-29-8833-7256

ASIA/PACIFIC

China - Xiamen
Tel: 86-592-2388138
Fax: 86-592-2388130

China - Zhuhai
Tel: 86-756-3210040
Fax: 86-756-3210049

India - Bangalore
Tel: 91-80-3090-4444
Fax: 91-80-3090-4123

India - New Delhi
Tel: 91-11-4160-8631
Fax: 91-11-4160-8632

India - Pune
Tel: 91-20-3019-1500

Japan - Osaka
Tel: 81-6-6152-7160
Fax: 81-6-6152-9310

Japan - Tokyo
Tel: 81-3-6880-3770
Fax: 81-3-6880-3771

Korea - Daegu
Tel: 82-53-744-4301
Fax: 82-53-744-4302

Korea - Seoul
Tel: 82-2-554-7200
Fax: 82-2-558-5932 or
82-2-558-5934

Malaysia - Kuala Lumpur
Tel: 60-3-6201-9857
Fax: 60-3-6201-9859

Malaysia - Penang
Tel: 60-4-227-8870
Fax: 60-4-227-4068

Philippines - Manila
Tel: 63-2-634-9065
Fax: 63-2-634-9069

Singapore
Tel: 65-6334-8870
Fax: 65-6334-8850

Taiwan - Hsin Chu
Tel: 886-3-5778-366
Fax: 886-3-5770-955

Taiwan - Kaohsiung
Tel: 886-7-213-7830

Taiwan - Taipei
Tel: 886-2-2508-8600
Fax: 886-2-2508-0102

Thailand - Bangkok
Tel: 66-2-694-1351
Fax: 66-2-694-1350

EUROPE

Austria - Wels
Tel: 43-7242-2244-39
Fax: 43-7242-2244-393

Denmark - Copenhagen
Tel: 45-4450-2828
Fax: 45-4485-2829

Finland - Espoo
Tel: 358-9-4520-820

France - Paris
Tel: 33-1-69-53-63-20
Fax: 33-1-69-30-90-79

France - Saint Cloud
Tel: 33-1-30-60-70-00

Germany - Garching
Tel: 49-8931-9700

Germany - Haan
Tel: 49-2129-3766400

Germany - Heilbronn
Tel: 49-7131-67-3636

Germany - Karlsruhe
Tel: 49-721-625370

Germany - Munich
Tel: 49-89-627-144-0
Fax: 49-89-627-144-44

Germany - Rosenheim
Tel: 49-8031-354-560

Israel - Ra'anana
Tel: 972-9-744-7705

Italy - Milan
Tel: 39-0331-742611
Fax: 39-0331-466781

Italy - Padova
Tel: 39-049-7625286

Netherlands - Drunen
Tel: 31-416-690399
Fax: 31-416-690340

Norway - Trondheim
Tel: 47-7289-7561

Poland - Warsaw
Tel: 48-22-3325737

Romania - Bucharest
Tel: 40-21-407-87-50

Spain - Madrid
Tel: 34-91-708-08-90
Fax: 34-91-708-08-91

Sweden - Gothenberg
Tel: 46-31-704-60-40

Sweden - Stockholm
Tel: 46-8-5090-4654

UK - Wokingham
Tel: 44-118-921-5800
Fax: 44-118-921-5820