

Evaluation Board for the **AD5317R** 10-Bit, Quad-Channel, Voltage Output DAC

FEATURES

- Full featured evaluation board in conjunction with **nanoDAC®** motherboard (**EVAL-MBnanoDAC-SDZ**)
- On-board references
- Various link options
- PC control in conjunction with Analog Devices, Inc., system demonstration platform (SDP)

PACKAGE CONTENTS

- EVAL-AD5317RDBZ** evaluation board
- EVAL-MBnanoDAC-SDZ** motherboard

SOFTWARE NEEDED

- EVAL-AD5317RDBZ** evaluation software

HARDWARE NEEDED

- EVAL-SDP-CB1Z** (**SDP-B** board), must be purchased separately

DOCUMENTS NEEDED

- Electronic version of the **AD5317R** data sheet
- Electronic version of the **EVAL-AD5317RDBZ** user guide

GENERAL DESCRIPTION

This user guide details the operation of the evaluation board for the **AD5317R** quad-channel, voltage output, digital-to-analog converter (DAC).

The evaluation board is designed to help users quickly prototype new **AD5317R** circuits and reduce design time. The **AD5317R** operates from a single 2.7 V to 5.5 V supply.

For full details, see the **AD5317R** data sheet, which must be used in conjunction with this user guide when using the evaluation board.

The evaluation board interfaces to the USB port of a PC via the **SDP-B** board. Software is available for download from the **EVAL-AD5317RDBZ** evaluation board page to allow the user to program the **AD5317R**.

EVAL-AD5317RDBZ, EVAL-MBnanoDAC-SDZ, AND SDP-B BOARDS

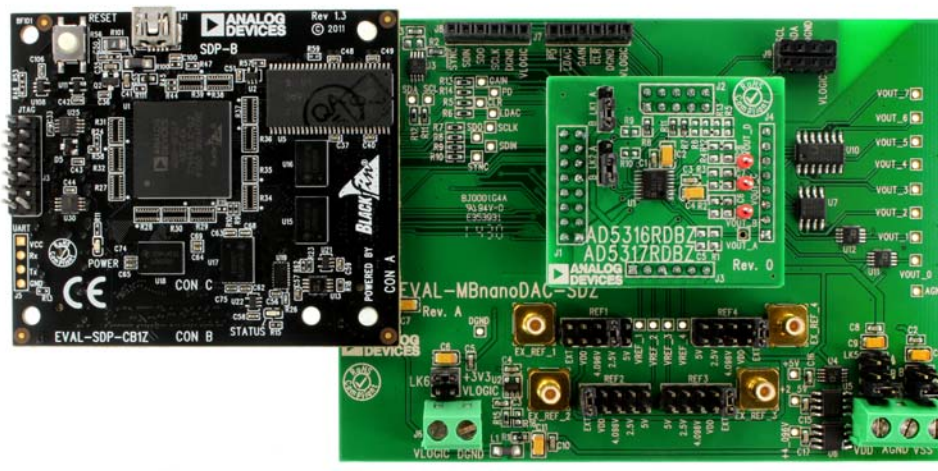

Figure 1.

14443-001

TABLE OF CONTENTS

Features	1	Motherboard Link Options.....	3
Package Contents.....	1	Daughter Board Link Options.....	3
Software Needed	1	Evaluation Board Software Quick Start Procedures	4
Hardware Needed	1	Installing the Software	4
Documents Needed.....	1	Running the Software	4
General Description	1	Software Operation	5
EVAL-AD5317RDBZ, EVAL-MBnanoDAC-SDZ, and SDP-B Boards.....	1	Evaluation Board Schematics and Artwork.....	7
Revision History	2	EVAL-MBnanoDAC-SDZ Motherboard	7
Evaluation Board Hardware.....	3	EVAL-AD5317RDBZ Daughter Board	10
Motherboard Power Supplies.....	3	Ordering Information.....	12
		Bill of Materials.....	12

REVISION HISTORY

2/2017—Revision 0: Initial Version

EVALUATION BOARD HARDWARE

MOTHERBOARD POWER SUPPLIES

The [EVAL-MBnanoDAC-SDZ](#) motherboard supports single and dual power supplies.

The [EVAL-AD5317RDBZ](#) evaluation board can be powered either from the SDP port or externally using the J5 and J6 connectors, as described in Table 1.

Table 1. Power Supply Connectors

Connector No.	Label	Voltage
J5, Pin 1 (J5-1)	VDD	Analog positive power supply, V_{DD} single supply 5 V, dual supply 5 V.
J5, Pin 2 (J5-2)	AGND	Analog ground.
J5, Pin 3 (J5-3)	VSS	Analog negative power supply, V_{SS} dual supply -5 V.
J6, Pin 1 (J6-1)	VLOGIC	Digital supply from 1.8 V to V_{DD} of the daughter board DAC.
J6, Pin 2 (J6-2)	DGND	Digital ground.

Both the AGND and DGND inputs are provided on the board. The AGND and DGND planes are connected at one location on the [EVAL-MBnanoDAC-SDZ](#). It is recommended that AGND and DGND not be connected elsewhere in the system to avoid ground loop problems.

All supplies are decoupled to ground with 10 μ F tantalum and 0.1 μ F ceramic capacitors.

Table 3. Link Functions

Link No.	Function
REF1 to REF4	These links select the reference source. Position EXT selects an off-board voltage reference via the appropriate EXT_REF_x connector. Position VDD selects V_{DD} as the reference source. Position 4.096V selects the on-board 4.096 V reference as the reference source. Position 2.5V selects the on-board 2.5 V reference as the reference source. Position 5V selects the on-board 5 V reference as the reference source.
LK5	This link selects the positive DAC analog voltage source. Position A selects the internal voltage source from the SDP-B board. Position B selects the internal voltage source 3.3 V from the ADP121 on the motherboard. Position C selects an external supply voltage, V_{DD} .
LK6	This link selects the VLOGIC voltage source. Position 3.3V selects the digital voltage source from the SDP-B board, 3.3 V. Position VLOGIC selects an external digital supply voltage, V_{LOGIC} .
LK7	This link selects the negative DAC analog voltage source. Position A selects V_{SS} . Position B selects AGND.

MOTHERBOARD LINK OPTIONS

A number of link options are incorporated in the [EVAL-MBnanoDAC-SDZ](#) and must be set for the required operating conditions before using the board. Table 2 describes the positions of the links to control the evaluation board via the [SDP-B](#) board using a PC and external power supplies. The functions of these link options are described in detail in Table 3. The positions listed in Table 2 and Table 3 match the evaluation board imprints (see Figure 12).

Table 2. Link Options Setup for [SDP-B](#) Control (Default)

Link No.	Position
REF1	2.5V
REF2	EXT
REF3	EXT
REF4	EXT
LK5	C
LK6	3.3V
LK7	B

DAUGHTER BOARD LINK OPTIONS

The printed circuit board (PCB) for this board is shared between the [EVAL-AD5316RDBZ](#) and [EVAL-AD5317RDBZ](#) daughter boards. To configure for the [EVAL-AD5317RDBZ](#) daughter board, it is recommended that LK1 and LK2 be removed for proper device operation.

EVALUATION BOARD SOFTWARE QUICK START PROCEDURES

INSTALLING THE SOFTWARE

The [EVAL-AD5317RDBZ](#) evaluation software is compatible with Windows® Vista (64-bit/32-bit), and Windows 7 (64-bit/32-bit).

The software must be installed before connecting the [SDP-B](#) board to the USB port of the PC to ensure that the [SDP-B](#) board is recognized when it connects to the PC.

To install the software, take the following steps:

1. Start the Windows operating system. Download the installation software from the [EVAL-AD5317RDBZ](#) evaluation board page.
2. Run the setup.exe file from the installer folder if it does not open automatically.
3. When the installation is complete, power up the evaluation board as described in the Motherboard Power Supplies section.
4. Connect the evaluation board to the [SDP-B](#) board and the [SDP-B](#) board to the PC using the USB cable included in the evaluation kit.
5. When the software detects the evaluation board, click through any dialog boxes that appear to finalize the installation.

RUNNING THE SOFTWARE

To run the program, take the following steps:

1. Connect the evaluation board to the [SDP-B](#) board and connect the USB cable between the [SDP-B](#) board and the PC.
2. Power up the evaluation board as described in the Motherboard Power Supplies section.
3. From the **Start** menu, click **All Programs, Analog Devices, AD5317R Evaluation Software**.
4. If the [SDP-B](#) board is not connected to the USB port when the software is launched, a connectivity error displays (see Figure 2). Connect the evaluation board to the USB port of the PC and wait a few seconds. When the [SDP-B](#) board is detected, the display is updated (see Figure 3).

Alternatively, the software can be used without an evaluation board. The software runs in simulation mode displaying expected outputs based on the input data. The main window of the [AD5317R](#) evaluation software then opens, as shown in Figure 4.

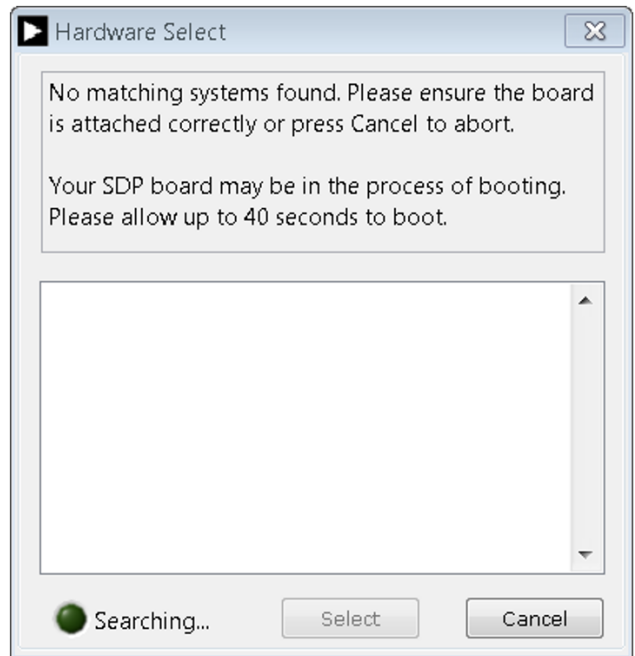

Figure 2. Connectivity Error

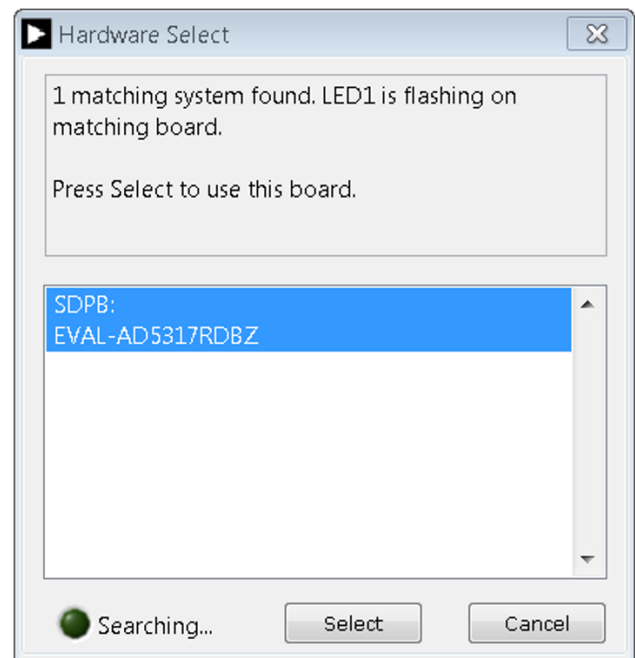

Figure 3. Hardware Select

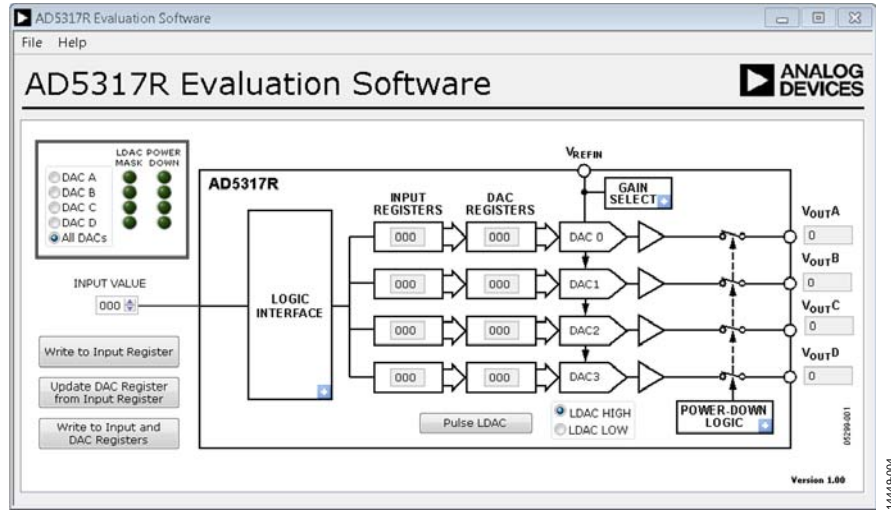

Figure 4. AD5317R Evaluation Software Main Window

SOFTWARE OPERATION

The software for the AD5317R allows the user to program values to the input and DAC registers of each DAC individually or collectively.

Write to Input Register

Click **Write to Input Register** to load the code of the input data control to the input register of selected DAC in the DAC selection box.

Update DAC Register from Input Register

Click **Update DAC Register from Input Register** to copy the value in the input register to the corresponding DAC register. The DAC outputs are automatically updated with the appropriate voltage. The LDAC MASK setting is ignored.

Write to DAC Register

Click **Write to Input and DAC Register** to load the code of the input data control to the input register and the DAC register of the selected DAC. The DAC outputs are automatically updated with the appropriate voltage. The LDAC MASK setting is ignored.

LDAC Control

Click **Pulse LDAC** to bring the LDAC pin low and then back high. Doing this copies the data from the input registers to the DAC registers, and the outputs update accordingly. Any DAC updates disabled by the LDAC MASK settings are ignored.

Alternatively, the LDAC pin can be set to logic high or logic low by clicking the corresponding **LDAC HIGH** or **LDAC LOW** option.

Power-Down Control

Each of the DACs can be powered down individually. Each of the DACs has an associated selection box allowing the selected DAC to operate in normal mode or power-down mode. Click the blue progressive disclosure option on the **POWER-DOWN LOGIC** block to access the **Powerdown Configuration** window, as shown in Figure 5. When the power-down settings for the DAC are selected, click **OK** to write the appropriate values to the AD5317R. The **POWER DOWN** indicator lights up accordingly when a DAC is powered down.

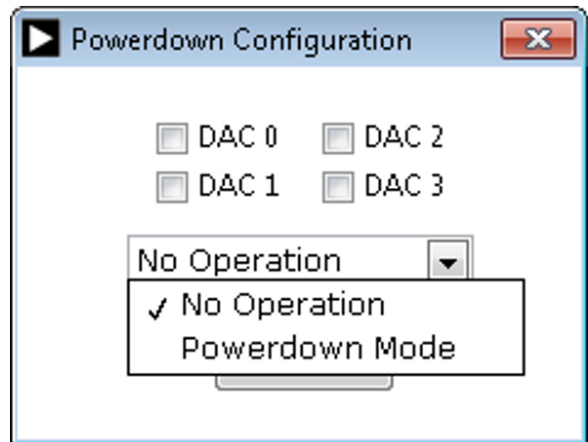

Figure 5. Powerdown Configuration Window

GAIN Control

To set the GAIN pin high or low, click the blue progressive disclosure option on the **GAIN SELECT** block to access the **Gain Control** window, as shown in Figure 6. In the **GAIN** selection box, select **X1** for a full-scale output of 2.5 V or select **X2** for a full-scale output of 5 V.

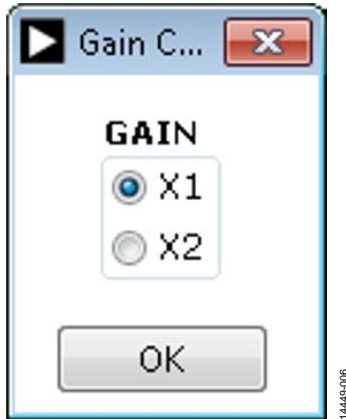

Figure 6. Gain Control Window

14449-006

LDAC Mask Register

Each DAC can be configured to respond to or ignore the LDAC pin settings in the **LDAC Configuration** window. Click the blue progressive disclosure option to access the **LDAC Configuration** window, as shown in Figure 7. When the LDAC selections are completed, click **OK** to write the appropriate values to the [AD5317R](#). The **LDAC MASK** indicator lights up accordingly when an LDAC mask of a DAC is enabled.

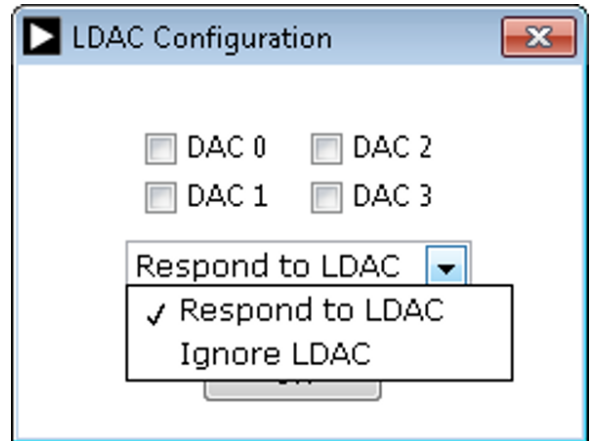

Figure 7. LDAC Configuration Window

14449-007

EVALUATION BOARD SCHEMATICS AND ARTWORK

EVAL-MBnanoDAC-SDZ MOTHERBOARD

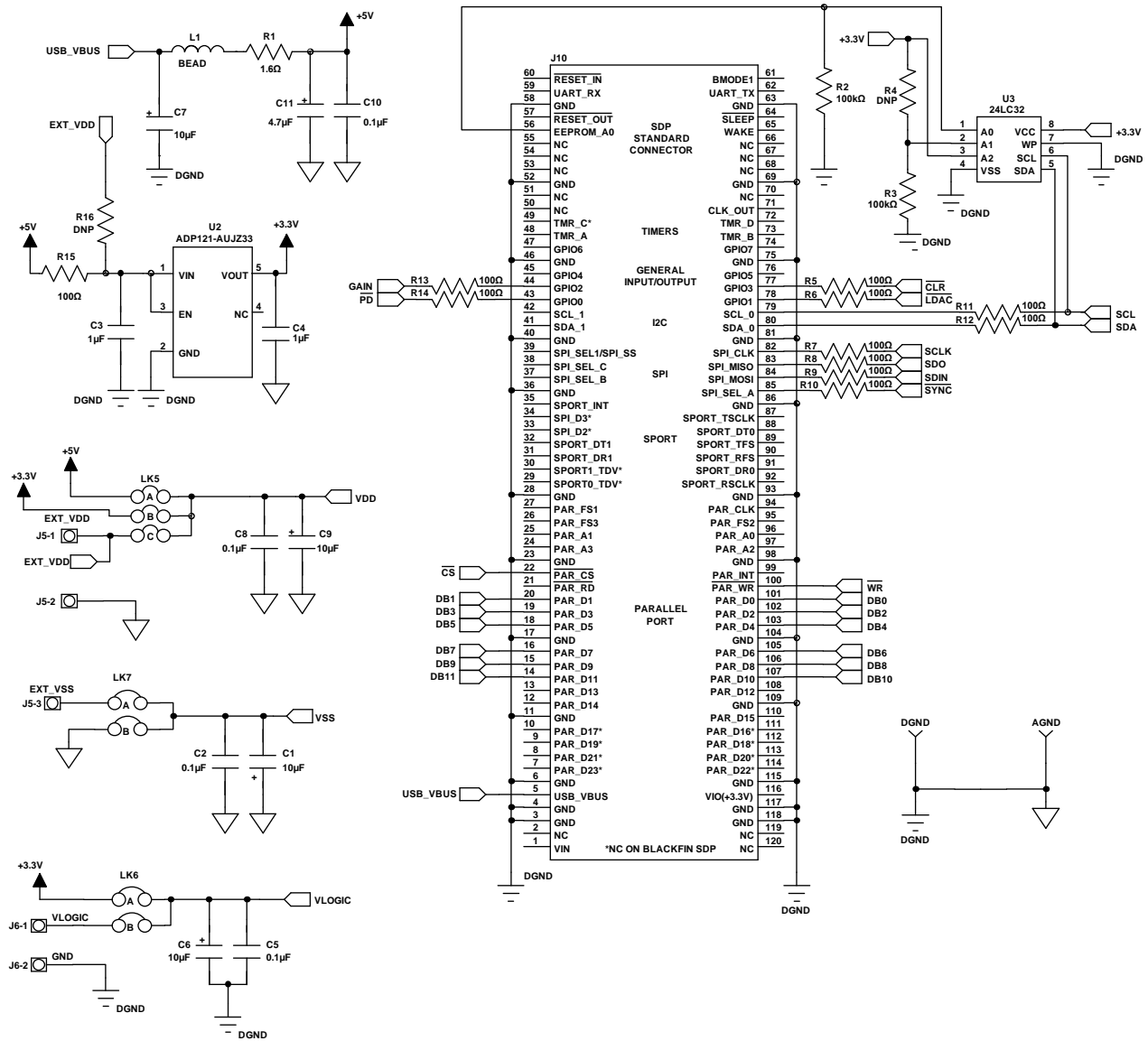

Figure 8. EVAL-MBnanoDAC-SDZ Motherboard SDP-B Connector and Power Supply

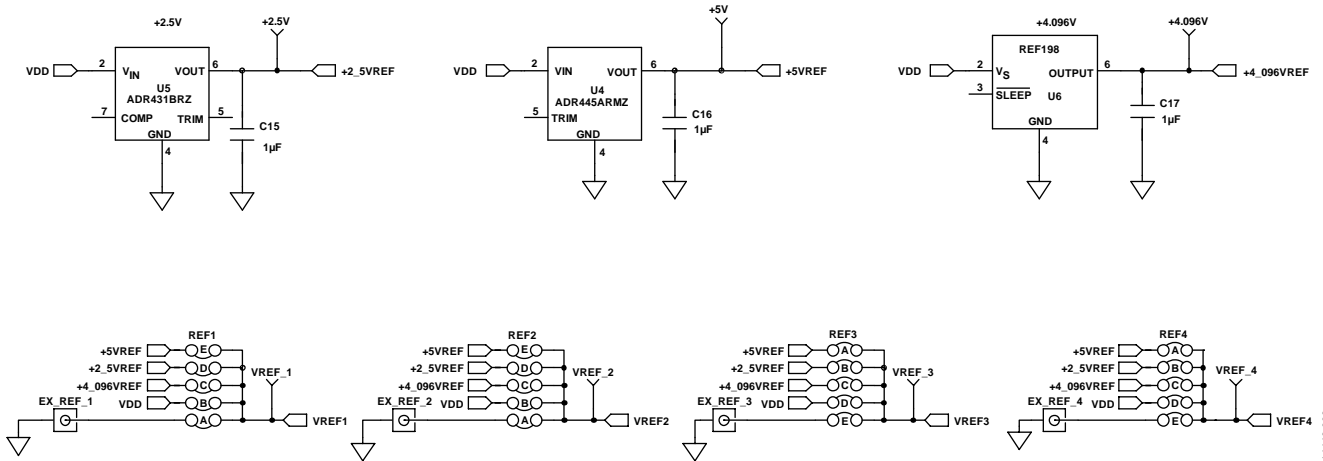

Figure 9. EVAL-MBnanoDAC-SDZ Motherboard Reference Voltage Selector Circuit

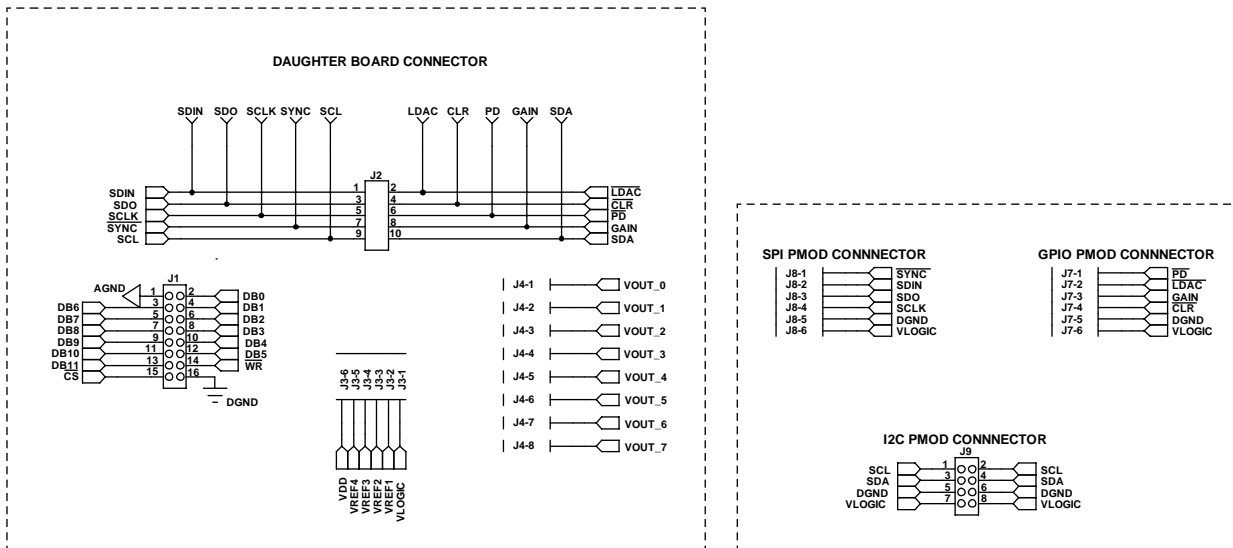

Figure 10. EVAL-MBnanoDAC-SDZ Motherboard Connectors to Daughter Board and Serial Interface

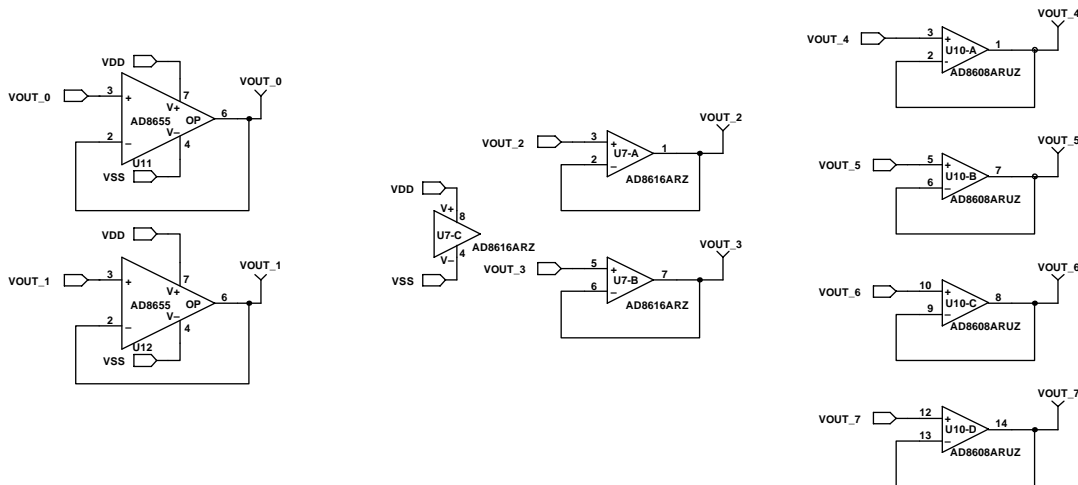

Figure 11. EVAL-MBnanoDAC-SDZ Motherboard Output Amplifier Circuit

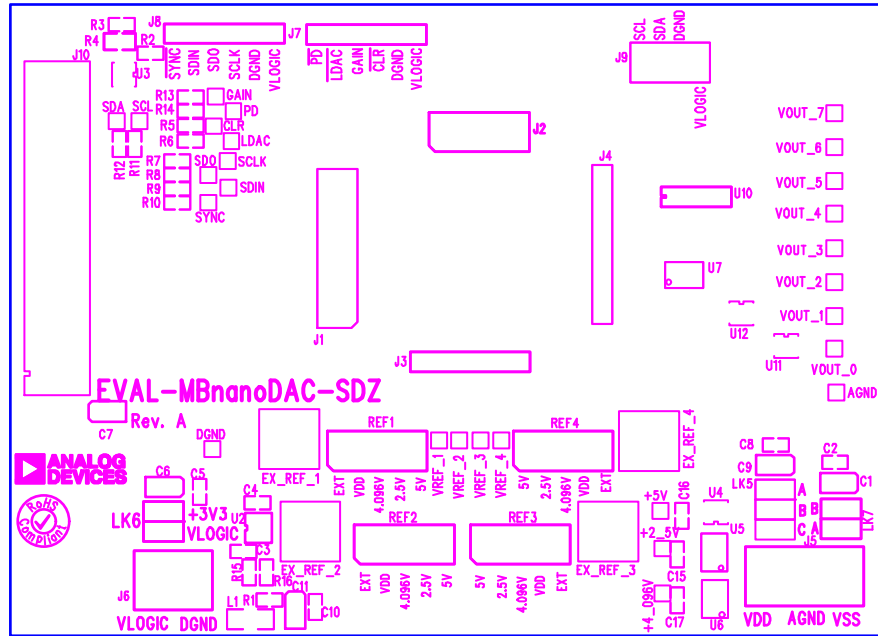

Figure 12. EVAL-MBnanoDAC-SDZ Motherboard Component Placement

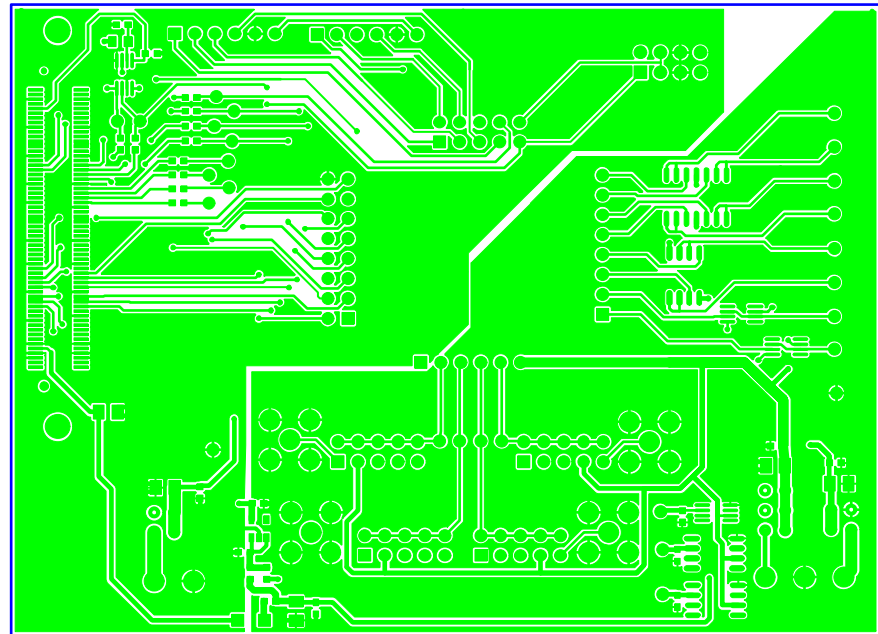
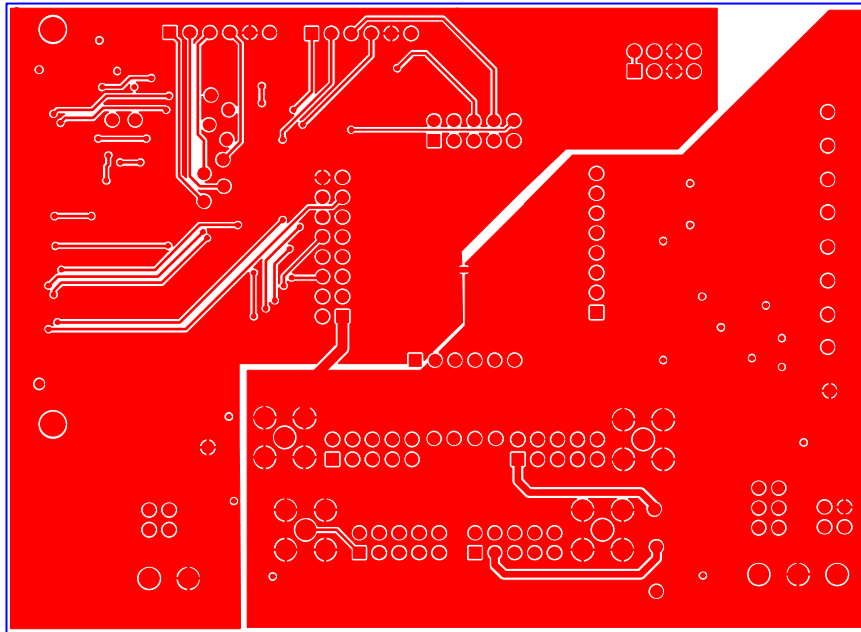

Figure 13. EVAL-MBnanoDAC-SDZ Motherboard Top Side Routing



14448-014

Figure 14. EVAL-MBnanoDAC-SDZ Motherboard Bottom Side Routing

EVAL-AD5317RDBZ DAUGHTER BOARD

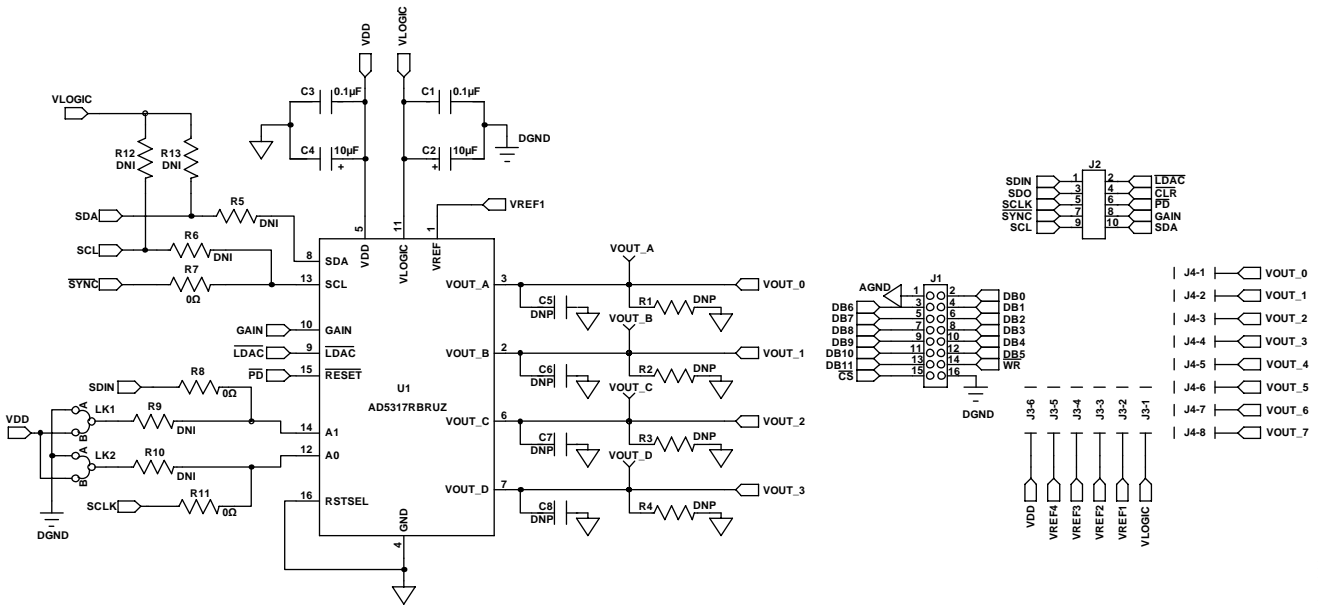

Figure 15. EVAL-AD5317RDBZ Daughter Board Schematics

14448-015

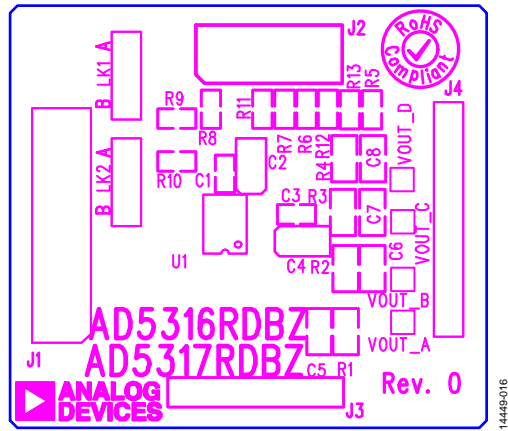

Figure 16. EVAL-AD5317RDBZ Daughter Board Component Placement

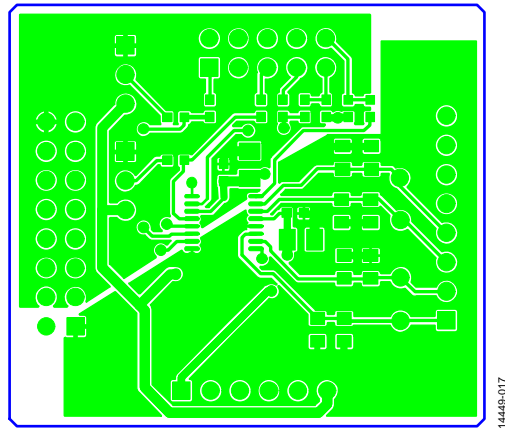

Figure 17. EVAL-AD5317RDBZ Daughter Board Top Side Routing

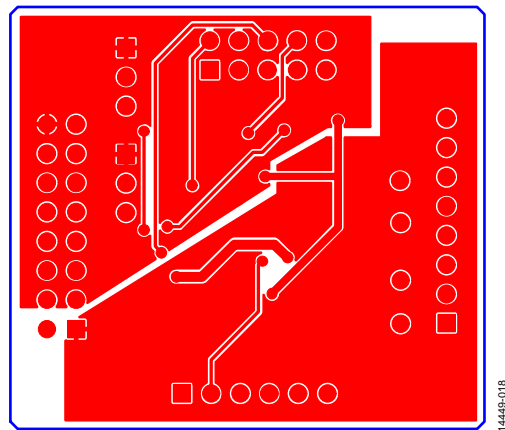

Figure 18. EVAL-AD5317RDBZ Daughter Board Bottom Side Routing

ORDERING INFORMATION

BILL OF MATERIALS

Table 4. EVAL-MBnanoDAC-SDZ Motherboard

Qty	Reference Designator	Description	Supplier/Part Number ^{1,2}
4	C1, C6, C7, C9	6.3 V, tantalum capacitor (Case A), 10 μ F, \pm 20%	FEC/1190107
4	C2, C5, C8, C10	50 V, X7R, ceramic capacitor, 0.1 μ F, \pm 10%	FEC/1759122
2	C3, C4	10 V, X5R, ceramic capacitor, 1 μ F, \pm 10%	GRM188R61A105KA61D
1	C11	6.3 V, tantalum capacitor (Case A), 4.7 μ F, \pm 20%	FEC/1432350
4	EXT_REF_1 to EXT_REF_4	Straight PCB mount SMB jack, 50 Ω	FEC/1206013
1	J1	Header, 2.54 mm, 2 \times 8-way	FEC/2308428
1	J2	Header, 2.54 mm, 2 \times 5-way	FEC/9689583
3	J3, J7, J8	Header, 2.54 mm, 1 \times 6-way	FEC/9689508
1	J4	Header, 2.54 mm, 1 \times 8-way	FEC/1766172
1	J5	3-pin terminal block	FEC/1667472
1	J6	2-pin terminal block	FEC/151789
1	J9	Header, 2.54 mm, 2 \times 4-way	FEC/1667509
1	J10	120-way connector	FEC/1324660
1	L1	Inductor, SMD, 600 Ω	FEC/9526862
1	LK5	6-pin (3 \times 2), 0.1", header and shorting block	FEC/148-535 and 150-411 (36-pin strip)
2	LK6, LK7	4-pin (2 \times 2), 0.1", header and shorting block	FEC/148-535 and 150-411 (36-pin strip)
4	REF1 to REF4	10-pin (5 \times 2), 0.1", header and shorting block	FEC/1022227 and 150-411
1	R1	Resistor, surge, 1.6 Ω , 1%, 0603	FEC/1627674
2	R2, R3	SMD resistor, 100 k Ω , 1%, 0603	FEC/9330402
11	R5 to R15	SMD resistor, 100 Ω , 1%, 0603	FEC/9330364
1	U2	3.3 V linear regulator	Analog Devices/ ADP121-AUJZ33R7
1	U3	32 kb I ² C serial EEPROM	FEC/1331330
1	U4	5 V reference, MSOP	Analog Devices/ ADR445ARMZ
1	U5	Ultralow noise XFET voltage reference	Analog Devices/ ADR431BRZ
1	U6	4.096 V reference	Analog Devices/ REF198ESZ
1	U7	Dual op amp	Analog Devices/ AD8616ARZ
1	U10	Quad op amp	Analog Devices/ AD8608ARMZ
2	U11, U12	Op amp	Analog Devices/ AD8655ARMZ

¹ FEC refers to Farnell Electronic Component Distributors.

² GRM refers to Murata Manufacturing Company.

Table 5. EVAL-AD5317RDBZ Daughter Board

Qty	Reference Designator	Description	Supplier/Part Number ¹
2	C1, C3	50 V, X7R, ceramic capacitor	FEC/1759122
2	C2, C4	6.3 V, tantalum capacitor (Case A)	FEC/1190107
4	C5 to C8	Not applicable	Not inserted
1	J1	16-pin (2 \times 8) header	FEC/2308428 inserted from solder side
1	J2	10-pin (2 \times 5) straight header, 2.54 mm pitch	FEC/9689583 inserted from solder side
1	J3	6-pin (1 \times 6) straight header, 2.54 mm pitch	FEC/9689508 inserted from solder side
1	J4	Header, 2.54 mm, PCB, 1 \times 8-way	FEC/1766172 inserted from solder side
2	LK1, LK2	Jumper block using 3-pin SIP header	FEC/1022248 and 150410
4	R1 to R4	Not applicable	Not inserted
4	R5, R6, R9, R10	Resistor, 0603, 1%, 0 Ω	Do not insert
3	R7, R8, R11	Resistor, 0603, 1%, 0 Ω	FEC/9331662
2	R12, R13	SMD resistor	Do not insert
1	U1	10-bit DAC	Analog Devices/ AD5317BRUZ
1	VOUT_A	Red test point	Do not insert
3	VOUT_B to VOUD_D	Red test point	FEC/8731144 (pack)

¹ FEC refers to Farnell Electronic Component Distributors

NOTES

I²C refers to a communications protocol originally developed by Philips Semiconductors (now NXP Semiconductors).



ESD Caution

ESD (electrostatic discharge) sensitive device. Charged devices and circuit boards can discharge without detection. Although this product features patented or proprietary protection circuitry, damage may occur on devices subjected to high energy ESD. Therefore, proper ESD precautions should be taken to avoid performance degradation or loss of functionality.

Legal Terms and Conditions

By using the evaluation board discussed herein (together with any tools, components documentation or support materials, the "Evaluation Board"), you are agreeing to be bound by the terms and conditions set forth below ("Agreement") unless you have purchased the Evaluation Board, in which case the Analog Devices Standard Terms and Conditions of Sale shall govern. Do not use the Evaluation Board until you have read and agreed to the Agreement. Your use of the Evaluation Board shall signify your acceptance of the Agreement. This Agreement is made by and between you ("Customer") and Analog Devices, Inc. ("ADI"), with its principal place of business at One Technology Way, Norwood, MA 02062, USA. Subject to the terms and conditions of the Agreement, ADI hereby grants to Customer a free, limited, personal, temporary, non-exclusive, non-sublicensable, non-transferable license to use the Evaluation Board FOR EVALUATION PURPOSES ONLY. Customer understands and agrees that the Evaluation Board is provided for the sole and exclusive purpose referenced above, and agrees not to use the Evaluation Board for any other purpose. Furthermore, the license granted is expressly made subject to the following additional limitations: Customer shall not (i) rent, lease, display, sell, transfer, assign, sublicense, or distribute the Evaluation Board; and (ii) permit any Third Party to access the Evaluation Board. As used herein, the term "Third Party" includes any entity other than ADI, Customer, their employees, affiliates and in-house consultants. The Evaluation Board is NOT sold to Customer; all rights not expressly granted herein, including ownership of the Evaluation Board, are reserved by ADI. CONFIDENTIALITY. This Agreement and the Evaluation Board shall all be considered the confidential and proprietary information of ADI. Customer may not disclose or transfer any portion of the Evaluation Board to any other party for any reason. Upon discontinuation of use of the Evaluation Board or termination of this Agreement, Customer agrees to promptly return the Evaluation Board to ADI. ADDITIONAL RESTRICTIONS. Customer may not disassemble, decompile or reverse engineer chips on the Evaluation Board. Customer shall inform ADI of any occurred damages or any modifications or alterations it makes to the Evaluation Board, including but not limited to soldering or any other activity that affects the material content of the Evaluation Board. Modifications to the Evaluation Board must comply with applicable law, including but not limited to the RoHS Directive. TERMINATION. ADI may terminate this Agreement at any time upon giving written notice to Customer. Customer agrees to return to ADI the Evaluation Board at that time. LIMITATION OF LIABILITY. THE EVALUATION BOARD PROVIDED HEREUNDER IS PROVIDED "AS IS" AND ADI MAKES NO WARRANTIES OR REPRESENTATIONS OF ANY KIND WITH RESPECT TO IT. ADI SPECIFICALLY DISCLAIMS ANY REPRESENTATIONS, ENDORSEMENTS, GUARANTEES, OR WARRANTIES, EXPRESS OR IMPLIED, RELATED TO THE EVALUATION BOARD INCLUDING, BUT NOT LIMITED TO, THE IMPLIED WARRANTY OF MERCHANTABILITY, TITLE, FITNESS FOR A PARTICULAR PURPOSE OR NONINFRINGEMENT OF INTELLECTUAL PROPERTY RIGHTS. IN NO EVENT WILL ADI AND ITS LICENSORS BE LIABLE FOR ANY INCIDENTAL, SPECIAL, INDIRECT, OR CONSEQUENTIAL DAMAGES RESULTING FROM CUSTOMER'S POSSESSION OR USE OF THE EVALUATION BOARD, INCLUDING BUT NOT LIMITED TO LOST PROFITS, DELAY COSTS, LABOR COSTS OR LOSS OF GOODWILL. ADI'S TOTAL LIABILITY FROM ANY AND ALL CAUSES SHALL BE LIMITED TO THE AMOUNT OF ONE HUNDRED US DOLLARS (\$100,000). EXPORT. Customer agrees that it will not directly or indirectly export the Evaluation Board to another country, and that it will comply with all applicable United States federal laws and regulations relating to exports. GOVERNING LAW. This Agreement shall be governed by and construed in accordance with the substantive laws of the Commonwealth of Massachusetts (excluding conflict of law rules). Any legal action regarding this Agreement will be heard in the state or federal courts having jurisdiction in Suffolk County, Massachusetts, and Customer hereby submits to the personal jurisdiction and venue of such courts. The United Nations Convention on Contracts for the International Sale of Goods shall not apply to this Agreement and is expressly disclaimed.

©2017 Analog Devices, Inc. All rights reserved. Trademarks and registered trademarks are the property of their respective owners.
UG14449-0-2/17(0)



www.analog.com