

Fast 150V High Side NMOS Static Switch Driver

FEATURES

- Wide Operating V_{IN} : Up to 135V (150V Abs Max)
- 1Ω Pull-Down, 2.2Ω Pull-Up for Fast Turn-On and Turn-Off Times
- 35ns Propagation Delays
- Internal Charge Pump for 100% Duty Cycle
- Adjustable Turn-On Slew Rate
- Gate Driver Supply from 3.5V to 15V
- Adjustable V_{IN} Overvoltage Lockout
- Adjustable Driver Supply V_{CC} Undervoltage Lockout
- CMOS Compatible Input
- Thermally Enhanced, High Voltage Capable 10-Lead MSOP Package

APPLICATIONS

- Static Switch Driver
- Load and Supply Switch Driver
- Electronic Valve Driver
- High Frequency High Side Gate Driver

DESCRIPTION

The **LTC[®]7001** is a fast high side N-channel MOSFET gate driver that operates from input voltages up to 135V. It contains an internal charge pump that fully enhances an external N-channel MOSFET switch, allowing it to remain on indefinitely.

Its powerful driver can easily drive large gate capacitances with very short transition times, making it well suited for both high frequency switching applications or static switch applications that require a fast turn-on and/or turn-off time.

The LTC7001 is available in the thermally enhanced 10-lead MSOP package.

LT, LT, LTC, LTM, Linear Technology and the Linear logo are registered trademarks of Analog Devices, Inc. All other trademarks are the property of their respective owners.

TYPICAL APPLICATION

High Voltage, High Side Switch with 100% Duty Cycle

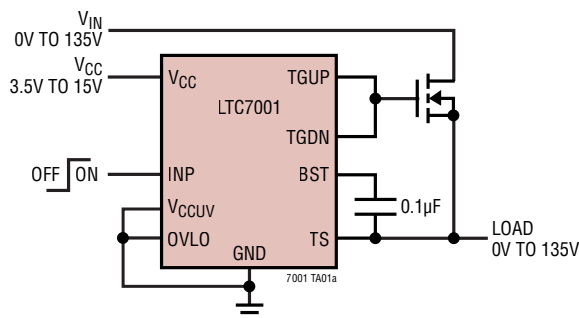

LTC7001 Driving a 1nF Capacitive Load

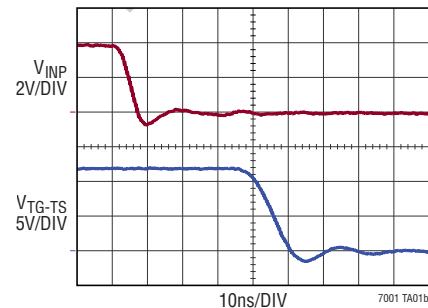

LTC7001

ABSOLUTE MAXIMUM RATINGS

(Note 1)

Supply Voltages

BST-TS	-0.3V to 15V
V _{CC}	-0.3V to 15V
TS Voltage	-6V to 150V
BST Voltage	-0.3V to 150V
INP Voltage	-6V to 15V
Driver Outputs TGUP, TGDN	(Note 6)
V _{CCUV} Voltage	-0.3 to 6V

OVLO Voltage	-0.3V to 6V
Operating Junction Temperature Range (Notes 2, 3, 4)	
LTC7001E, LTC7001I,	-40°C to 125°C
LTC7001H,	-40°C to 150°C
LTC7001MP	-55°C to 150°C
Storage Temperature Range	-65°C to 150°C
Lead Temperature (Soldering, 10 sec)	
MSOP Package	300°C

PIN CONFIGURATION

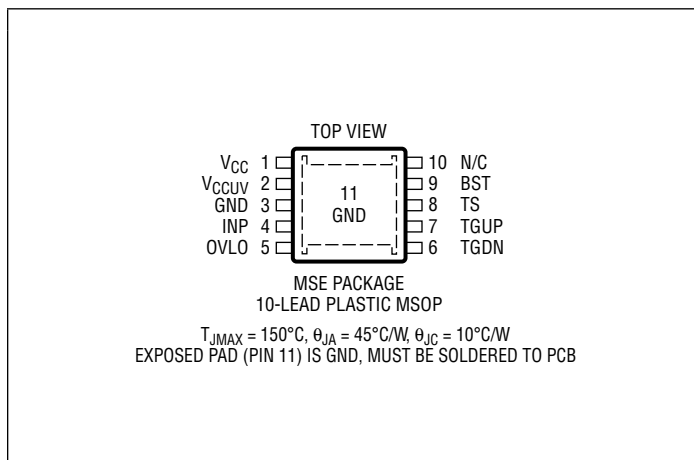

ORDER INFORMATION <http://www.linear.com/product/LTC7001#orderinfo>

LEAD FREE FINISH	TAPE AND REEL	PART MARKING*	PACKAGE DESCRIPTION	TEMPERATURE RANGE
LTC7001EMSE#PBF	LTC7001EMSE#TRPBF	7001	10-Lead Plastic MSOP	-40°C to 125°C
LTC7001IMSE#PBF	LTC7001IMSE#TRPBF	7001	10-Lead Plastic MSOP	-40°C to 125°C
LTC7001HMSE#PBF	LTC7001HMSE#TRPBF	7001	10-Lead Plastic MSOP	-40°C to 150°C
LTC7001MPMSE#PBF	LTC7001MPMSE#TRPBF	7001	10-Lead Plastic MSOP	-55°C to 150°C

Consult LTC Marketing for parts specified with wider operating temperature ranges. *Temperature grades are identified by a label on the shipping container.

For more information on lead free part marking, go to: <http://www.linear.com/leadfree/>

For more information on tape and reel specifications, go to: <http://www.linear.com/tapeandree/>. Some packages are available in 500 unit reels through designated sales channels with #TRMPBF suffix.

ELECTRICAL CHARACTERISTICS The ● denotes the specifications which apply over the specified operating junction temperature range, otherwise specifications are at $T_A = 25^\circ\text{C}$ (Note 2). $V_{CC} = V_{BST} = 10\text{V}$, $V_{TS} = \text{GND} = 0\text{V}$, unless otherwise noted.

SYMBOL	PARAMETER	CONDITIONS	MIN	TYP	MAX	UNITS
Input Supplies						
	TS Operating Voltage Range		0		135	V
	V_{CC} Supply Current (Note 5) ON Mode Sleep Mode	$V_{BST-TS} = 13\text{V}$ $V_{INP} = 4\text{V}$ $V_{INP} = 0.4\text{V}$		27 27	50 50	μA μA
	V_{CC} Undervoltage Lockout	$V_{CCUV} = \text{OPEN}$ V_{CC} Rising V_{CC} Falling Hysteresis $V_{CCUV} = 0\text{V}$ V_{CC} Rising V_{CC} Falling Hysteresis $V_{CCUV} = 1.5\text{V}$ V_{CC} Rising V_{CC} Falling Hysteresis	● ● ● ●	6.5 5.8 7.0 6.4 600 3.1 2.8 9.7 9.1	7.5 6.9 3.7 3.4 10.5 10.3	V V mV V V mV V V mV
Bootstrapped Supply (BST-TS)						
V_{BST-TS}	V_{TG} Above V_{TS} with $INP = 3\text{V}$ (DC)	$V_{CC} = V_{TS} = 7\text{V}$, $I_{BST} = 0\mu\text{A}$ $V_{CC} = V_{TS} = 10\text{V}$, $I_{BST} = 0\mu\text{A}$ $V_{TS} = 135\text{V}$, $I_{BST} = 0\mu\text{A}$	● ● ●	9 10 10	11 12 12	14 14 14 μA
	Charge Pump Output Current	$V_{TS} = 20\text{V}$, $V_{BST-TS} = 10\text{V}$	●	-15	-30	μA
	BST-TS Floating UVLO	V_{BST-TS} Rising V_{BST-TS} Falling			3.1 2.8	V V
Output Gate Driver (TG)						
	TG Pull-Up Resistance	$V_{CC} = V_{BST} = 12\text{V}$	●	2.2	7	Ω
	TG Pull-Down Resistance	$V_{CC} = V_{BST} = 12\text{V}$	●	1	4	Ω
t_r	Output Rise Time	10% to 90%, $CL = 1\text{nF}$ 10% to 90%, $CL = 10\text{nF}$		13 90		ns ns
t_f	Output Fall Time	10% to 90%, $CL = 1\text{nF}$ 10% to 90%, $CL = 10\text{nF}$		13 40		ns ns
t_{PLH} t_{PHL}	Input to Output Propagation Delay	V_{INP} Rising, $CL = 1\text{nF}$ V_{INP} Falling, $CL = 1\text{nF}$	● ●	35 35	70 70	ns ns
Operation						
V_{IH} V_{IL}	Input Threshold Voltages	V_{INP} Rising V_{INP} Falling Hysteresis	● ●	1.7 1.3	2 1.6 400	V V mV
	Input Pull-Down Resistance	$V_{INP} = 1\text{V}$		1		$\text{M}\Omega$
	OVLO Pin Threshold Voltage	Rising Falling Hysteresis		1.16 1.05	1.21 1.10 110	V V mV
	OVLO Pin Leakage Current	$V_{OVLO} = 1.3\text{V}$		-100	0	nA
	V_{CCUV} Pull-Up Current	$V_{CCUV} = 1\text{V}$		-11.3	-10	μA

ELECTRICAL CHARACTERISTICS

Note 1: Stresses beyond those listed under Absolute Maximum Ratings may cause permanent damage to the device. Exposure to any Absolute Maximum Rating condition for extended periods may affect device reliability and lifetime.

Note 2: The LTC7001 is tested under pulsed load conditions such that $T_J \approx T_A$. The LTC7001E is guaranteed to meet performance specifications from 0°C to 85°C. Specifications over the -40°C to 125°C operating junction temperature range are assured by design, characterization and correlation with statistical process controls. The LTC7001I is guaranteed over the -40°C to 125°C operating junction temperature range, the LTC7001H is guaranteed over the -40°C to 150°C operating junction temperature range and the LTC7001MP is tested and guaranteed over the -55°C to 150°C operating junction temperature range.

High junction temperatures degrade operating lifetimes; operating lifetime is derated for junction temperatures greater than 125°C. Note that the maximum ambient temperature consistent with these specifications is determined by specific operating conditions in conjunction with board layout, the rated package thermal impedance and other environmental factors.

Note 3: The junction temperature (T_J , in °C) is calculated from the ambient temperature (T_A , in °C) and power dissipation (P_D , in Watts) according to the formula:

$$T_J = T_A + (P_D \cdot \theta_{JA}), \text{ where } \theta_{JA} \text{ is } 45^\circ\text{C/W.}$$

Note 4: This IC includes over temperature protection that is intended to protect the device during momentary overload conditions. The maximum rated junction temperature will be exceeded when this protection is active. Operation above the specified absolute maximum operating junction temperature may impair device reliability or permanently damage the device.

Note 5: Dynamic supply current is higher due to the gate charge being delivered at the switching frequency. See Applications Information.

Note 6: Do not apply a voltage or current source to these pins. They must be connected to capacitive loads only; otherwise permanent damage may occur.

TYPICAL PERFORMANCE CHARACTERISTICS $T_A = 25^\circ\text{C}$, unless otherwise noted.

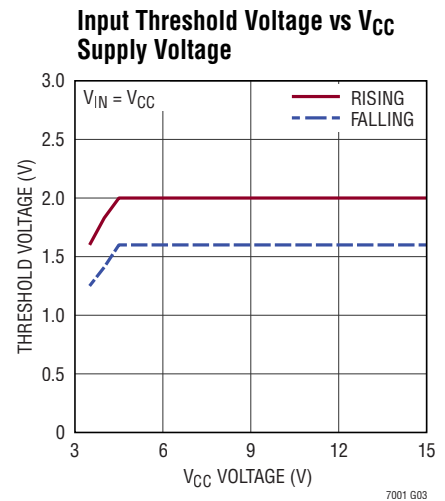
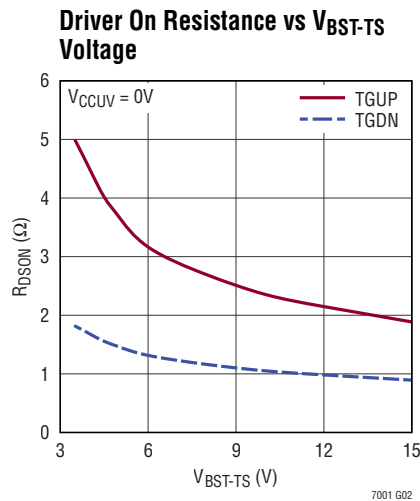
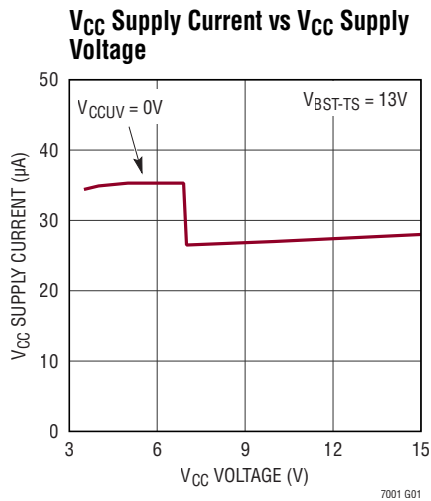

TYPICAL PERFORMANCE CHARACTERISTICS $T_A = 25^\circ\text{C}$, unless otherwise noted.

Charge Pump No-Load Output Voltage vs V_{TS}

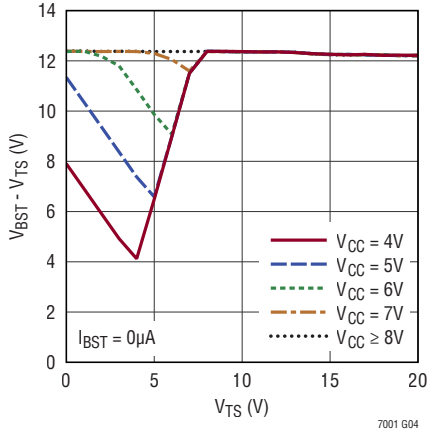

Charge Pump Load Regulation

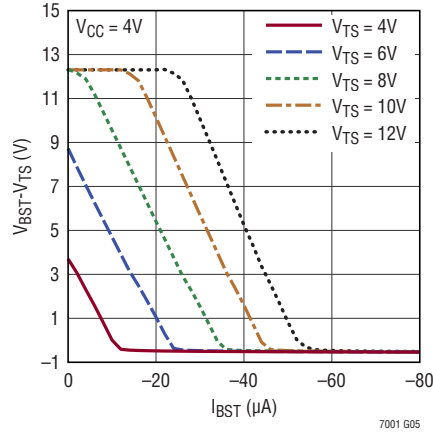

Charge Pump Output Current vs V_{TS}

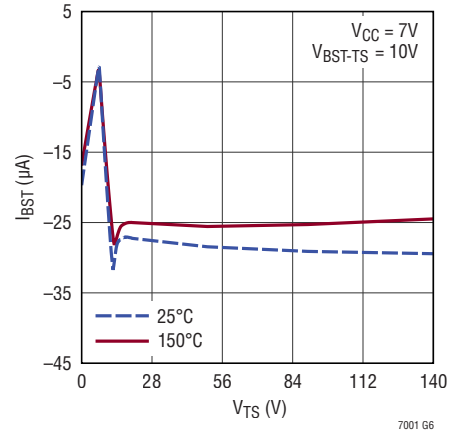

OVLO Threshold Voltage vs Temperature

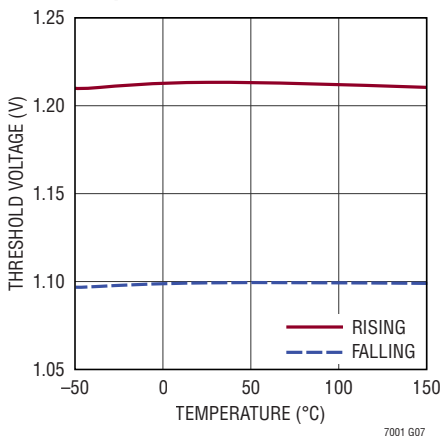

V_{CCUV} Lockout vs Temperature

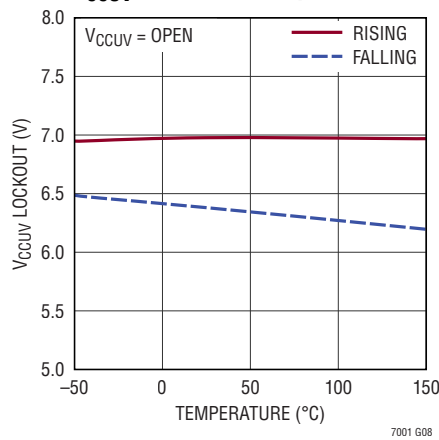

Driver On Resistance vs Temperature

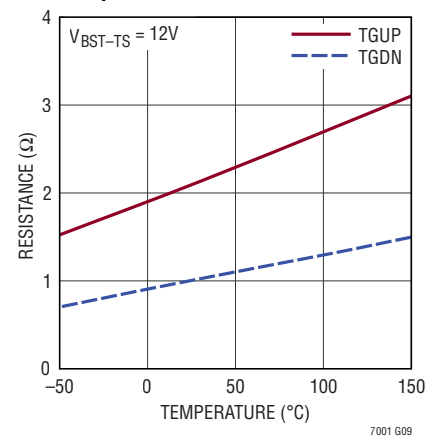

V_{CC} Supply Current vs Temperature

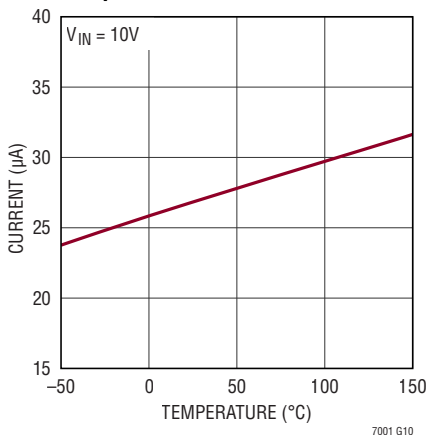

Input Threshold Voltage vs Temperature

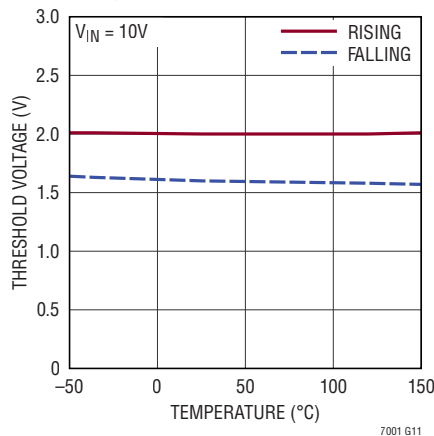

V_{BST-TS} Floating UVLO Voltage vs Temperature

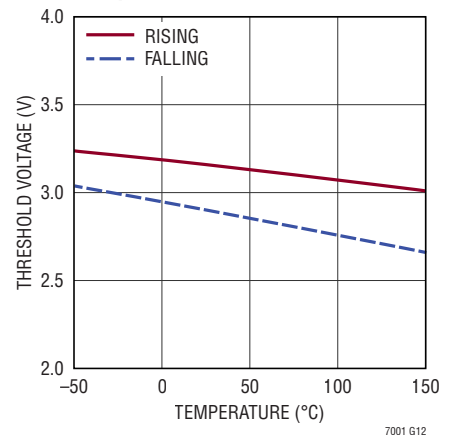

PIN FUNCTIONS

V_{CC} (Pin 1): Main Supply Pin. A bypass capacitor with a minimum value of 0.1 μ F should be tied between this pin and GND.

V_{CCUV} (Pin 2): V_{CC} Supply Undervoltage Lockout. A resistor on this pin sets the reference for the Gate Drive undervoltage lockout. The voltage on this pin in the range of 0.5V to 1.5V is multiplied by seven to be the undervoltage lockout for the Gate Drive (V_{CC} pin). Short to ground to set the minimum gate drive UVLO of 3.5V. Leave open to set gate drive UVLO to 7.0V

GND (Pin 3, Exposed Pad Pin 11): Ground. The exposed paddle must be soldered to the PCB for rated electrical and thermal performance.

INP (Pin 4): Input Signal. CMOS compatible input reference to GND that sets the state of TGDN and TGUP pins (see Applications Information). INP has an internal 1M Ω pull-down to GND to keep TGDN pulled to TS during startup transients.

OVLO (Pin 5): Overvoltage Lockout Input. Connect to the input supply through a resistor divider to set the lockout level. A voltage on this pin above 1.21V causes TGDN

to be pulled to TS. Normal operation resumes when the voltage on this pin decreases below 1.11V. OVLO should be tied to GND when not used.

TGDN (Pin 6): High Current Gate Driver Pull-Down. This pin pulls down to TS. For the fastest turn-off, tie this pin directly to the gate of the external high side MOSFET.

TGUP (Pin 7): High Current Gate Driver Pull-Up. This pin pulls up to BST. Tie this pin to TGDN for maximum gate drive transition speed. A resistor can be connected between this pin and the gate of the external MOSFET to control the inrush current during turn-on. See Applications Information.

TS (Pin 8): Top (High Side) source connection or GND if used in ground referenced applications.

BST (Pin 9): High Side Bootstrapped Supply. An external capacitor with a minimum value of 0.1 μ F should be tied between this pin and TS. Voltage swing on this pin is 12V to (V_{TS} + 12V).

NC (Pin 10): No Connect. This pin should be floated.

BLOCK DIAGRAM

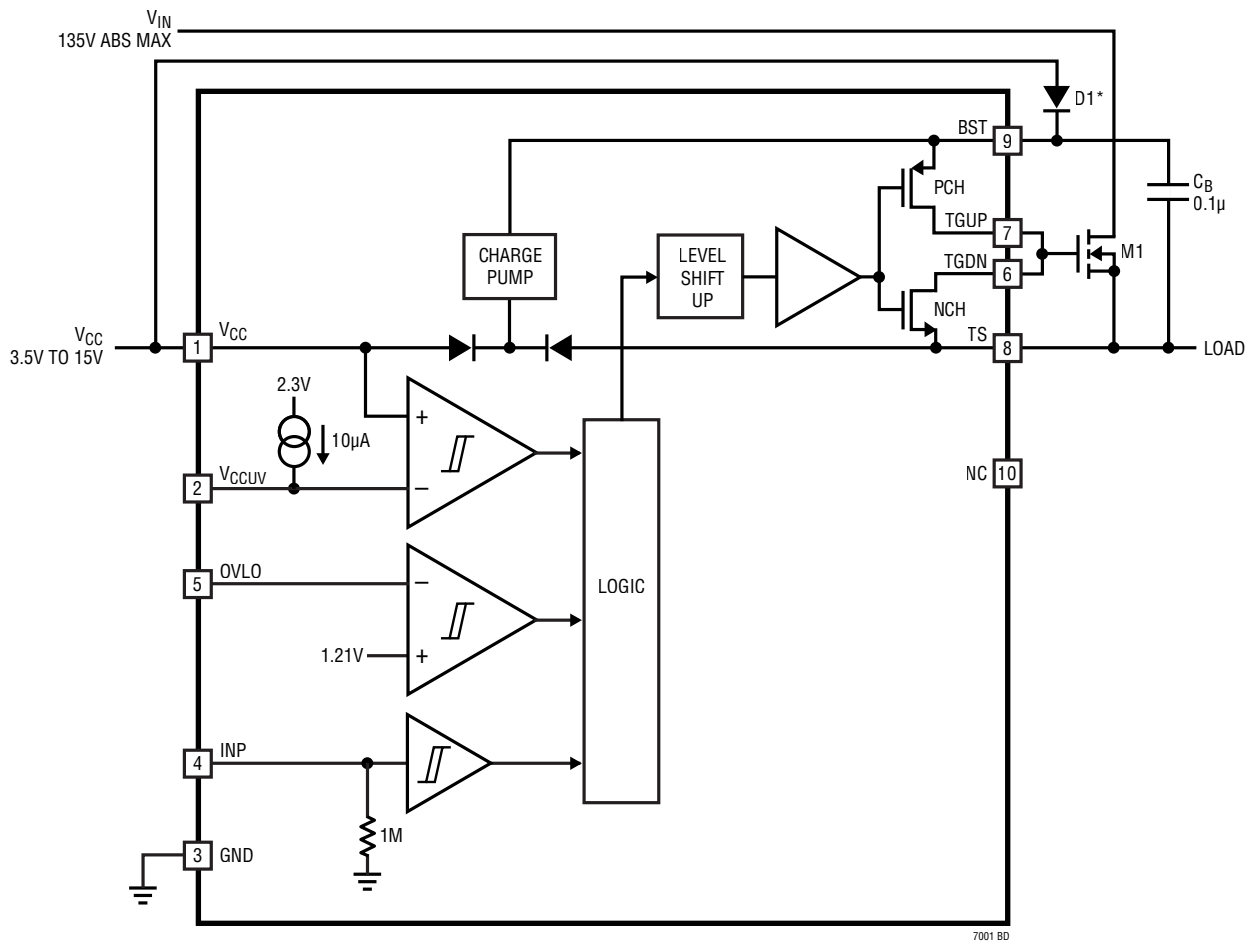

*OPTIONAL

7001 BD

TIMING DIAGRAM

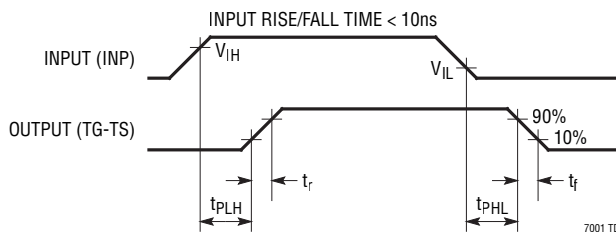

OPERATION (Refer to Block Diagram)

The LTC7001 is designed to receive a ground-referenced, low voltage digital input signal, INP and quickly drive a high side N-channel power MOSFET whose drain can be up to 150V above ground. The LTC7001 is capable of driving a 1nF load using a 12V bootstrapped supply voltage ($V_{BST}-V_{TS}$) with 35ns of propagation delay and fast rise/fall times. The high gate drive voltage reduces external power losses associated with external MOSFET on-resistance. The strong drivers not only provide fast turn on and off times but hold the TGUP and TGDN to TS voltages in the desired state in the presence of high slew rate transients which can occur driving inductive loads at high voltages.

Internal Charge Pump

The LTC7001 contains an internal charge pump that enables the MOSFET gate drive to have 100% duty cycle. The charge pump regulates the BST-TS voltage to 12V reducing external power losses associated with external MOSFET on-resistance. The charge pump uses the higher voltage of TS or V_{CC} as the source for the charge.

Protection Circuitry

When using the LTC7001, care must be taken not to exceed any of the ratings specified in the Absolute Maximum Ratings section. As an added safeguard, the LTC7001 incorporates an overtemperature shutdown feature. If the

junction temperature reaches approximately 180°C, the LTC7001 will enter thermal shutdown mode and TGDN will be pulled to TS. After the part has cooled below 160°C, TGDN will be allowed to go back high. The overtemperature level is not production tested. The LTC7001 is guaranteed to start at temperatures below 150°C.

The LTC7001 additionally implements protection features which prohibit TGDN from going high when V_{CC} or ($V_{BST}-V_{TS}$) are not within proper operating ranges. By using a resistive divider from V_{IN} to ground the OVLO pin can serve as a precise input supply voltage overvoltage lockout. TGDN is pulled to TS when OVLO rises above 1.21V, so OVLO can be configured to limit switching to a specific range on input supply voltages.

V_{CC} contains an undervoltage lockout feature that will pull TGDN to TS and is configured by the V_{CCUV} pin. If V_{CCUV} is open, TGDN is pulled to TS until V_{CC} is greater than 7.0V. By using a resistor from V_{CCUV} to ground, the rising undervoltage lockout on V_{CC} can be adjusted from 3.5V to 10.5V.

An additional internal undervoltage lockout is included that will pull TGDN to TS when the floating voltage from BST to TS is less than 3.1V (typical).

APPLICATIONS INFORMATION

Input Stage

The LTC7001 employs CMOS compatible input thresholds that allow a low voltage digital signal connected to INP to drive standard power MOSFETs. The LTC7001 contains an internal voltage regulator which biases the input buffer connected to INP allowing the input thresholds ($V_{IH} = 2.0V$, $V_{IL} = 1.6V$) to be independent of variations in V_{CC} . The 400mV hysteresis between V_{IH} and V_{IL} eliminates false triggering due to noise events. However, care should be taken to keep INP from any noise pickup, especially in high frequency, high voltage applications.

INP also contains an internal $1M\Omega$ pull-down resistor to ground, keeping TGDN pulled to TS during startup and other unknown transient events.

INP has an Absolute Maximum of $-6V$ to $+15V$ which allows the signal driving INP to have voltage excursions outside the normal power supply and ground range. It is not uncommon for signals routed with long PCB traces and driven with fast rise/fall times to inductively ring to voltages higher than power supply or lower than ground.

Output Stage

A simplified version of the LTC7001 output stage is shown in Figure 1. The pull-down device is an N-channel MOSFET with a typical $1\Omega R_{DS(ON)}$ and the pull-up device is a P-channel MOSFET with a typical $2.2\Omega R_{DS(ON)}$. The pull-up and pull-down pins have been separated to allow the turn-on transient to be controlled while maintaining a fast turn-off.

The LTC7001 powerful output stage (1Ω pull-up and 2.2Ω pull-down) minimizes transition losses when driving external MOSFETs and keeps the MOSFET in the state commanded by INP even if high voltage and high frequency transients couple from the power MOSFET back to the driving circuitry.

The large gate drive voltage on TGUP and TGDN reduces conduction losses in the external MOSFET because $R_{DS(ON)}$ is inversely proportional to its gate overdrive ($V_{GS} - V_{TH}$).

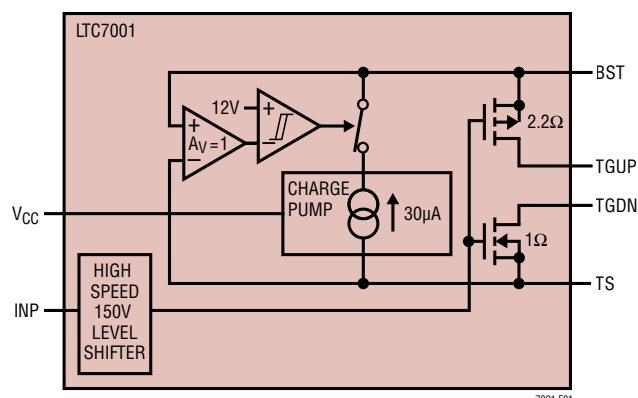

Figure 1. Simplified Output Stage

External Overvoltage Lockout

The OVLO pin can be configured as a precise overvoltage (OVLO) lockout on the V_{IN} supply with a resistive divider from V_{IN} to ground. A simple resistive divider can be used as shown in Figure 2 to meet specific V_{IN} voltage requirements. When OVLO is greater than 1.21V, TGDN will be pulled to TS and the external MOSFET will be turned off.

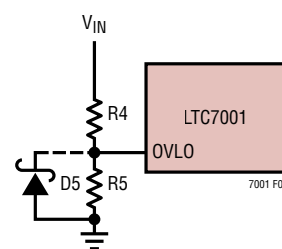

Figure 2. Adjustable OV Lockout

The current that flows through the R4 – R5 divider will directly add to the current drawn from V_{IN} and care should be taken to minimize the impact of this current on the overall current used by the application circuit. Resistor values in the megaohm range may be required to keep the impact of the quiescent shutdown and sleep currents low. To pick resistor values, the sum total of $R4 + R5$ (R_{TOTAL}) should

APPLICATIONS INFORMATION

be chosen first based on the allowable DC current that can be drawn from V_{IN} . The individual values of R4 and R5 can then be calculated from the following equations:

$$R5 = R_{TOTAL} \cdot \frac{1.21V}{\text{Rising } V_{IN} \text{ OVLO Threshold}}$$

$$R4 = R_{TOTAL} - R5$$

For applications that do not need a precise external OVLO the OVLO pin is required to be tied directly to ground.

Be aware that the OVLO pin cannot be allowed to exceed its absolute maximum rating of 6V. To keep the voltage on the OVLO pin from exceeding 6V, the following relationship should be satisfied:

$$V_{IN(MAX)} \cdot \left(\frac{R5}{R4 + R5} \right) < 6V$$

If the $V_{IN(MAX)}$ relationship for the OVLO pin cannot be satisfied, an external 5V Schottky diode should also be placed from OVLO to ground in addition to any lockout setting resistors.

Bootstrapped Supply (BST-TS)

An external bootstrapped capacitor, C_B , connected between BST and TS supplies the gate drive voltage for the MOSFET driver. The LTC7001 keeps the BST-TS supply charged with an internal charge pump, allowing for duty cycles up to 100%. When the high side external MOSFET is to be turned on, the driver places the C_B voltage across the gate-source of the MOSFET. This enhances the high side MOSFET and turns it on. The source of the MOSFET, TS, rises to V_{IN} and the BST pin follows. With the high side MOSFET on, the BST voltage is above the input supply; $V_{BST} = V_{TS} + 12V$. The boost capacitor, C_B , supplies the charge to turn on the external MOSFET and needs to have at least 10 times the charge to turn on the external MOSFET fully. The charge to turn on the external MOSFET is referred to gate charge, Q_G , and is typically specified in the external MOSFET data sheet. Gate charge can range from 5nC to hundreds nCs and is influenced by the gate

drive level and the type of external MOSFET used. For most applications, a capacitor value of 0.1 μ F for C_B will be sufficient. However, the following relationship for C_B should be maintained:

$$C_B > \frac{10 \cdot \text{External MOSFET } Q_G}{1V}$$

The internal charge pump that charges the BST-TS supply outputs approximately 30 μ A to the BST pin. If the time to charge the external bootstrapped capacitor, C_B from initial power-up with the internal charge pump is not sufficient for the application, a low reverse leakage external silicon diode, D1 with a reverse voltage rating greater than V_{IN} connected between V_{CC} and BST should be used as shown in Figure 3. An external silicon diode between V_{CC} and BST should be used if the following relationship cannot be met:

$$\text{BST Diode Required if Power-Up to INP Going High} < \frac{C_{BST} \cdot 12V}{30\mu A} \cong 40ms$$

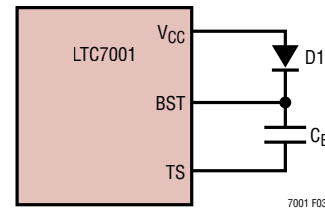

Figure 3. External BST Diode

Another reason to use an external silicon diode between V_{CC} and BST is if the external MOSFET is switched at frequency so high that the BST-TS supply collapses. An external silicon diode between V_{CC} and BST should be used if the following relationship cannot be met:

$$\text{BST Diode Required if Switching Frequency} > \frac{30\mu A}{2 \cdot \text{MOSFET } Q_G} \cong 500Hz$$

APPLICATIONS INFORMATION

A Schottky diode should not be used between V_{CC} and BST, because the reverse leakage of the Schottky diode at hot will be more current than the charge pump can overcome.

Some example silicon diodes with low leakage include:

- MMBD1501A, Fairchild Semiconductor
- CMPD3003, Central Semiconductor

V_{CC} Undervoltage Comparator

The LTC7001 contains an adjustable undervoltage lockout (UVLO) on the V_{CC} voltage that pulls TGDN to TS and can be easily programmed using a resistor (R_{VCCUV}) between the V_{CCUV} pin and ground. The voltage generated on V_{CCUV} by R_{VCCUV} and the internal $10\mu A$ current source set the V_{CC} UVLO. The rising V_{CC} UVLO is internally limited within the range of 3.5V and 10.5V. If V_{CCUV} is open the rising V_{CC} UVLO is set internally to 7.0V. The value of resistor for a particular rising V_{CC} UVLO can be selected using Figure 4 or the following equation:

$$R_{DRVUV} = \frac{\text{Rising } V_{CC} \text{ UVLO}}{70\mu A}$$

Where $3.5V < \text{Rising } V_{CC} \text{ UVLO} < 10.5V$.

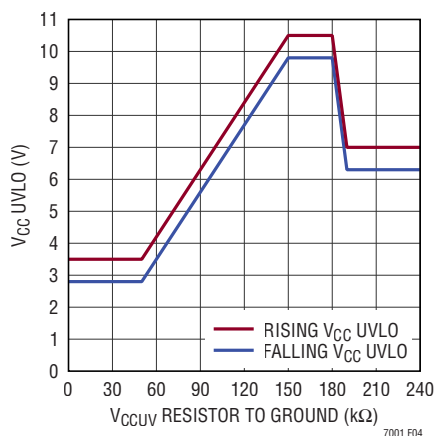

Figure 4. V_{CCUV} Resistor Selection

MOSFET Selection

The most important parameters in high voltage applications for MOSFET selection are the breakdown voltage BV_{DSS} , on-resistance $R_{DS(ON)}$ and the safe operating area, SOA.

The MOSFET, when off, will see the full input range of the input power supply plus any additional ringing than can occur when driving an inductive load.

External conduction losses are minimized when using low $R_{DS(ON)}$ MOSFETs. Since many high voltage MOSFETs have higher threshold voltages (typical $V_{TH} \geq 5V$) and $R_{DS(ON)}$ is directly related to the $(V_{GS} - V_{TH})$ of the MOSFET, the LTC7001 maximum gate drive of greater than 10V makes it an ideal solution to minimize external conduction losses associated with external high voltage MOSFETs.

SOA is specified in Typical Characteristic curves in power N-channel MOSFET data sheets. The SOA curves show the relationship between the voltages and current allowed in a timed operation of a power MOSFET without causing damage to the MOSFET.

Limiting Inrush Current During Turn-On

Large capacitive loads such as complex electrical systems with large bypass capacitors should be driven using the circuit shown in Figure 5. The pull-up gate drive to the power MOSFET from TGUP is passed through an RC delay network, R_G and C_G , which greatly reduces the turn-on ramp rate of the MOSFET. Since the MOSFET source voltage follows the gate voltage, the load is powered smoothly from ground. This dramatically reduces the inrush current from the source supply and reduces the transient ramp rate of the load, allowing for slower activation of sensitive electrical loads. The turn-off of the MOSFET is not affected by the R_C delay network as the pull-down for the MOSFET gate is directly from the TGDN pin. Note that the voltage rating on capacitor C_G needs to be the same or higher than the external MOSFET and C_{LOAD} .

APPLICATIONS INFORMATION

Adding C_G to the gate of the external MOSFET can cause high frequency oscillation. A low power, low ohmic value resistor (10Ω) should be placed in series with C_G to dampen the oscillations as shown in Figure 5 whenever C_G is used in an application. Alternatively, the low ohmic value resistor can be placed in series with the gate of the external MOSFET.

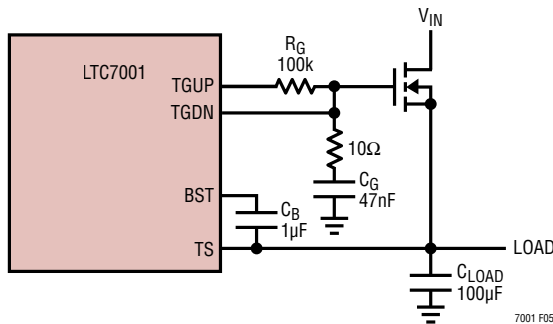

Figure 5. Powering Large Capacitive Loads

When C_G is added to the circuit in Figure 5, the value of the bootstrap capacitor, C_B , must be increased to be able to supply the charge to both to MOSFET gate and capacitor C_G . The relationship for C_B that needs to be maintained when C_G is used is given by:

$$C_B > \frac{10 \cdot \text{MOSFET } Q_G}{1V} + 10 \cdot C_G$$

Optional Schottky Diode Usage on TS

When turning off a power MOSFET that is connected to an inductive component (inductor, long wire or complex load), the TS pin can be pulled below ground until the current in the inductive component has completely discharged. The TS pin is tolerant of voltages down to $-6V$, however, an optional Schottky diode with a voltage rating at least as high as the load voltage should be connected between TS and ground to prevent discharging the inductive through the TS pin of the LTC7001. See Figure 6.

The values for R_G and C_G to limit the inrush current can be calculated from the below equation:

$$I_{IN_RUSH} \cong \frac{0.7 \cdot 12V \cdot C_{LOAD}}{R_G \cdot C_G}$$

For the values shown in Figure 5 the inrush current will be:

$$I_{IN_RUSH} \cong \frac{0.7 \cdot 12V \cdot 100\mu F}{100k\Omega \cdot 0.047\mu F} \cong 180mA$$

Correspondingly, the ramp rate at the load for the circuit in Figure 5 is approximately:

$$\frac{\Delta V_{LOAD}}{\Delta T} \cong \frac{0.7 \cdot 12V}{R_G \cdot C_G} \cong 2V/ms$$

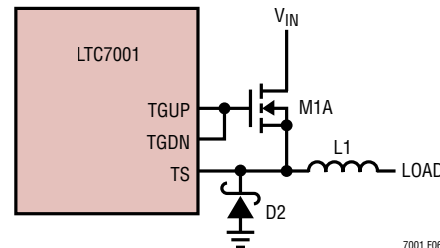

Figure 6. Optional Schottky Diode Usage

TYPICAL APPLICATIONS

Reverse Input Protection

To protect the load from discharging back into V_{IN} when the V_{IN} voltage drops below the load voltage, two external N-channel MOSFETs should be used and must be in a back-to-back arrangement as shown in Figure 7. Dual N-channel packages such as the Vishay/Siliconix Si7956DP are a good choice for space saving designs.

PC Board Layout Considerations

1. *Solder the exposed pad* on the backside of the LTC7001 package directly to the ground plane of the board.

2. Limit the resistance of the TS trace, by making it short and wide.
3. C_B needs to be close to chip.
4. Always include an option in the PC board layout to place a resistor in series with the gate of any external MOSFET. High frequency oscillations are design dependent, and having the option to add a series dampening resistor can save a design iteration of the PC board.

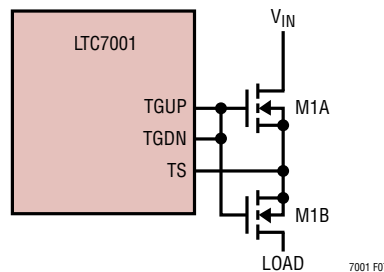
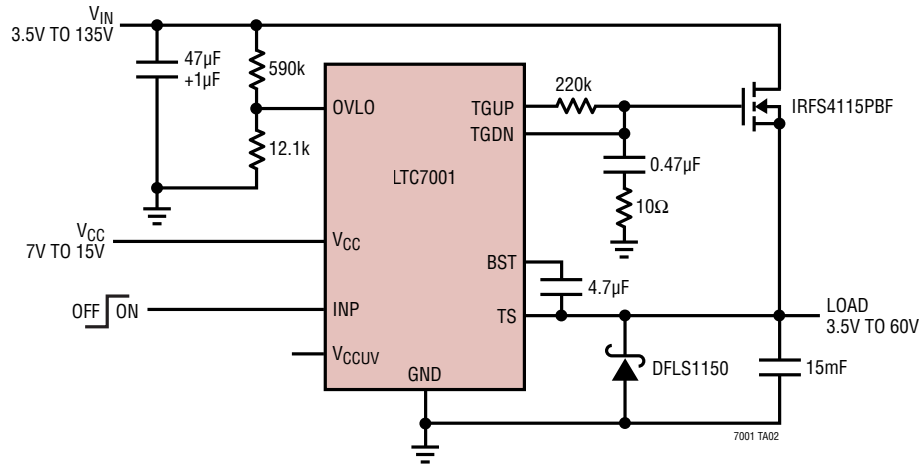

Figure 7. Protecting Load from Voltage Drops on V_{IN}

TYPICAL APPLICATIONS

High Side Switch with Inrush Control and OVLO



High Side Switch with VCCUV and OVLO

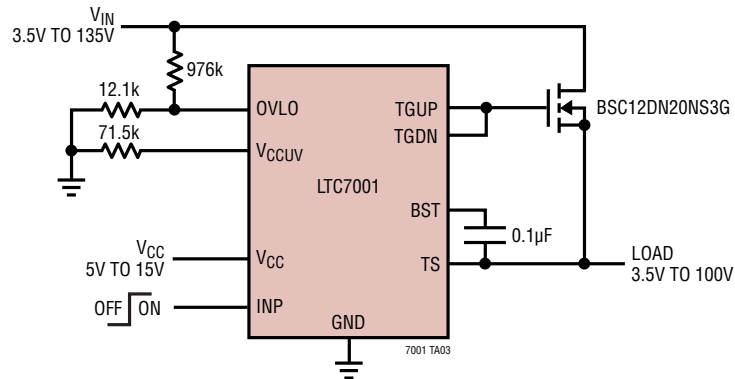

PACKAGE DESCRIPTION

Please refer to <http://www.linear.com/product/LTC7001#packaging> for the most recent package drawings.

MSE Package 10-Lead Plastic MSOP, Exposed Die Pad (Reference LTC DWG # 05-08-1664 Rev I)

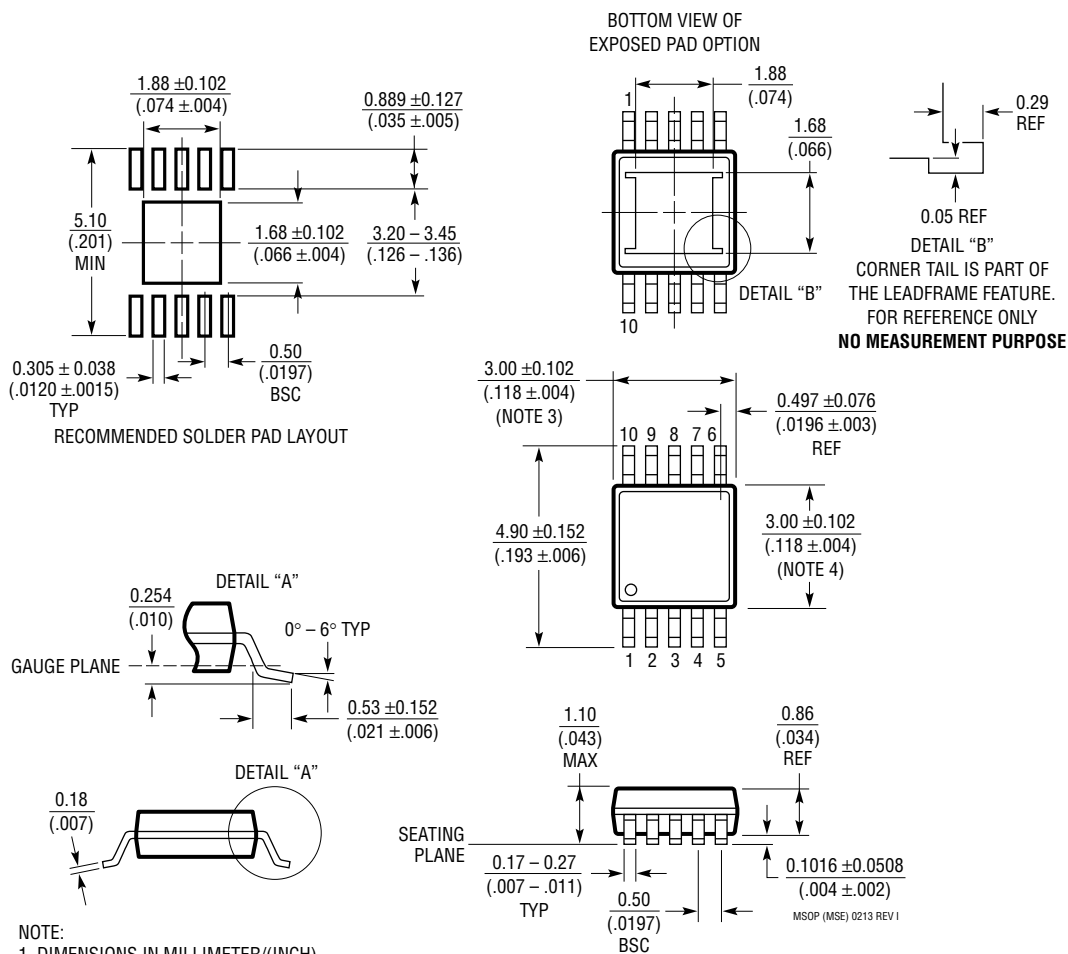

NOTE:

1. DIMENSIONS IN MILLIMETER/(INCH)
2. DRAWING NOT TO SCALE
3. DIMENSION DOES NOT INCLUDE MOLD FLASH, PROTRUSIONS OR GATE BURRS. MOLD FLASH, PROTRUSIONS OR GATE BURRS SHALL NOT EXCEED 0.152mm (.006") PER SIDE
4. DIMENSION DOES NOT INCLUDE INTERLEAD FLASH OR PROTRUSIONS. INTERLEAD FLASH OR PROTRUSIONS SHALL NOT EXCEED 0.152mm (.006") PER SIDE
5. LEAD COPLANARITY (BOTTOM OF LEADS AFTER FORMING) SHALL BE 0.102mm (.004") MAX
6. EXPOSED PAD DIMENSION DOES INCLUDE MOLD FLASH. MOLD FLASH ON E-PAD SHALL NOT EXCEED 0.254mm (.010") PER SIDE.

TYPICAL APPLICATION

Motor Driver

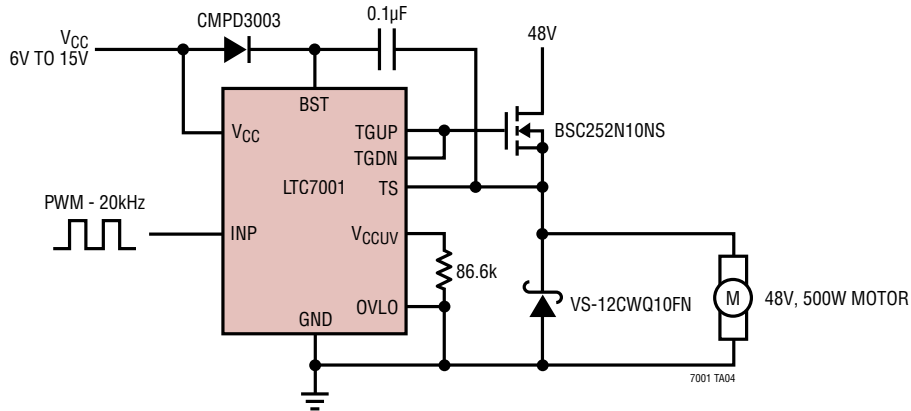

RELATED PARTS

PART NUMBER	DESCRIPTION	COMMENTS
LTC7000/ LTC7000-1	Fast 150V Protected High Side NMOS Static Switch Driver	3.5V to 150V Operation, Short-Circuit Protected, $\Delta V_{SNS} = 30\text{mV}$, $I_Q = 35\mu\text{A}$, Turn-On ($C_L = 1\text{nF}$) = 35ns, Internal Charge Pump
LTC4440/ LTC4440-5/ LTC4440A-5	High Speed, High Voltage High Side Gate Driver	Up to 100V Supply Voltage, $8\text{V} \leq V_{CC} \leq 15\text{V}$, 2.4A Peak Pull-Up/1.5Ω Peak Pull-Down
LTC7138	High Efficiency, 150V 250mA/400mA Synchronous Step-Down Regulator	Integrated Power MOSFETs, $4\text{V} \leq V_{IN} \leq 150\text{V}$, $0.8\text{V} \leq V_{OUT} \leq V_{IN}$, $I_Q = 12\mu\text{A}$, MSOP-16 (12)
LTC7103	105V, 2.3A Low EMI Synchronous Step-Down Regulator	$4.4\text{V} \leq V_{IN} \leq 105\text{V}$, $1\text{V} \leq V_{OUT} \leq V_{IN}$, $I_Q = 2\mu\text{A}$ Fixed Frequency 200kHz to 2MHz, 5mm × 6mm QFN
LTC7801	150V Low I_Q , Synchronous Step-Down DC/DC Controller	$4\text{V} \leq V_{IN} \leq 140\text{V}$, 150V Abs Max, $0.8\text{V} \leq V_{OUT} \leq 60\text{V}$, $I_Q = 40\mu\text{A}$, PLL Fixed Frequency 320kHz to 2.25MHz
LT1910	Protected High Side MOSFET Driver	8V to 48V Operation, $\Delta V_{SNS} = 65\text{mV}$, $I_Q = 110\mu\text{A}$, Turn-On ($C_L = 1\text{nF}$) = 220µs, Internal Charge Pump
LTC1255	Dual 24V High Side MOSFET Driver	9V to 24V Operation, $\Delta V_{SNS} = 100\text{mV}$, $I_Q = 600\mu\text{A}$, Turn-On ($C_L = 1\text{nF}$) = 100µs, Internal Charge Pump
LTC4364	Surge Stopper with Ideal Diode	4V to 80V Operation, $\Delta V_{SNS} = 50\text{mV}$, $I_Q = 425\mu\text{A}$, Turn-On ($C_L = 1\text{nF}$) = 500µs, Internal Charge Pump
LTC7860	High Efficiency Switching Surge Stopper	4V to 60V Operation, $\Delta V_{SNS} = 95\text{mV}$, $I_Q = 370\mu\text{A}$, PMOS Driver
LTC4231	Micropower Hot Swap Controller	2.7V to 36V Operation, $\Delta V_{SNS} = 50\text{mV}$, $I_Q = 4\mu\text{A}$, Turn-On ($C_L = 1\text{nF}$) = 1ms, Internal Charge Pump
LTC3895	150V Low I_Q , Synchronous Step-Down DC/DC Controller	PLL Fixed Frequency 50kHz to 900kHz, $4\text{V} \leq V_{IN} \leq 140\text{V}$, $0.8\text{V} \leq V_{OUT} \leq 60\text{V}$, $I_Q = 40\mu\text{A}$
LTC4380	Low Quiescent Current Surge Stopper	4V to 80V Operation, $\Delta V_{SNS} = 50\text{mV}$, $I_Q = 8\mu\text{A}$, Turn-On = 5ms, Internal Charge Pump
LTC3639	High Efficiency, 150V 100mA Synchronous Step-Down Regulator	Integrated Power MOSFETs, $4\text{V} \leq V_{IN} \leq 150\text{V}$, $0.8\text{V} \leq V_{OUT} \leq V_{IN}$, $I_Q = 12\mu\text{A}$, MSOP-16(12)