

40mm sq.

San Ace 40



General Specifications

- Material Frame: Aluminum, Impeller: Plastics (Flammability: UL94V-0)
- Expected Life Refer to specifications (L10:Survival rate:90% at 60°C , rated voltage, and continuously run in a free air state)
- Lead Wire ⊕red ⊖black (Sensor) yellow (Control) brown
- Storage Temperature -30°C to +70°C (Non-condensing)

40×40×28mm (Mass : 55g) **9GE type** **Low vibration**

Specifications

The following nos. **have PWM controls and pulse sensors.**

Model No.	Rated Voltage [V]	Operating Voltage Range [V]	PWM duty cycle※ [%]	Rated Current [A]	Rated Input [W]	Rated Speed [min ⁻¹]	Max. Airflow [m ³ /min] [CFM]	Max. Static Pressure [Pa] [inchH ₂ O]	SPL [dB(A)]	Operating Temperature [°C]	Expected Life [h]
9GE0412P3K03	12	10.8 to 13.2	100	0.84	10.08	16,500	0.76 26.8	415 1.666	58	-20 to +60	40,000/60°C
			0	0.07	0.84	3,000	0.13 4.6	13 0.052	17		
9GE0412P3J03			100	0.65	7.8	15,000	0.69 24.4	343.0 1.378	56		
			0	0.05	0.6	2,650	0.12 4.2	10.7 0.042	14		
9GE0412P3G03			100	0.47	5.64	13,000	0.60 21.2	260 1.044	52		
			0	0.05	0.6	2,400	0.11 3.9	8.2 0.033	13		

※PWM Frequency : 25kHz

Models with pulse sensors (no PWM control function) or lock sensors are available as options. Please refer to the index (p. 476).

Dimensions (unit: mm)

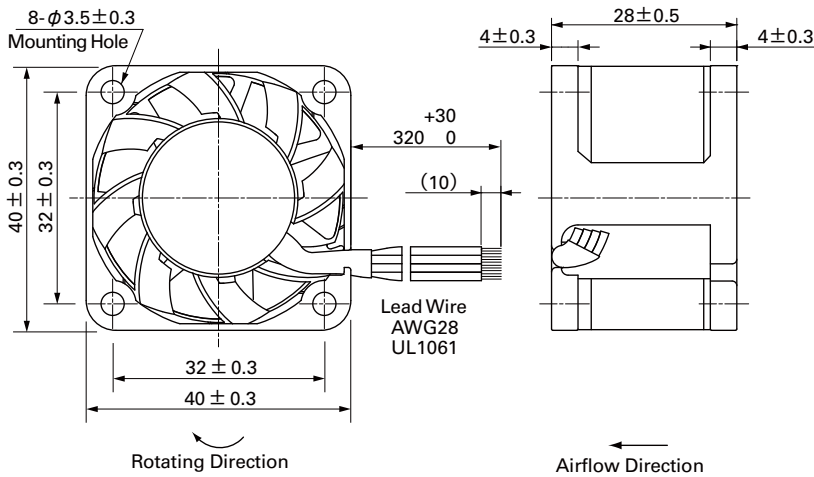

Reference Dimensions of Mounting Holes and Vent Opening (unit: mm)

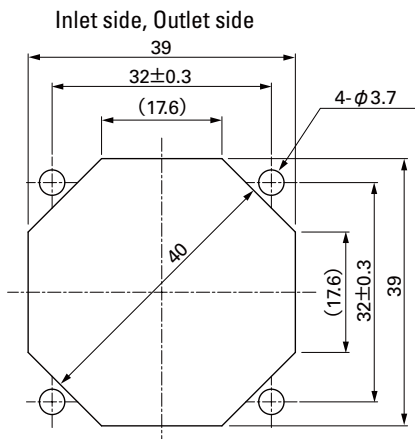

Options (unit: mm)

Finger Guards

Model : 109-059 Surface treatment : Nickel-chrome plating (silver)
: 109-059H : Cation electropainting (black)

Color

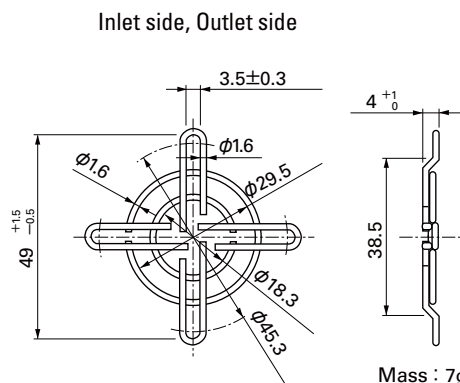

Mass : 7g

Airflow - Static Pressure Characteristics

PWM Duty Cycle

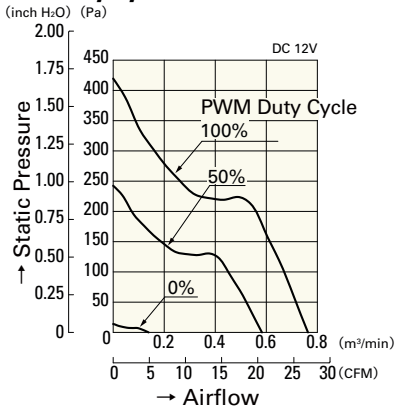

9GE0412P3K03

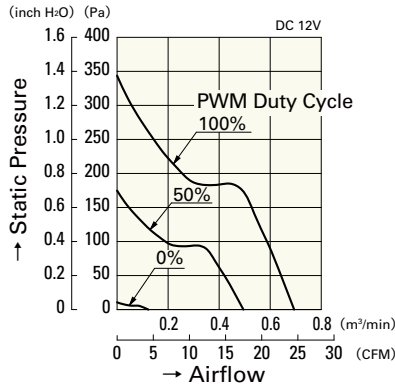

9GE0412P3J03

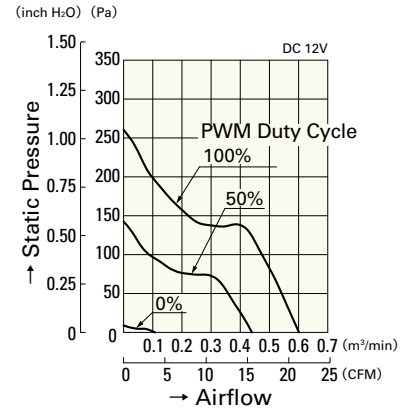

9GE0412P3G03

Operating Voltage Range

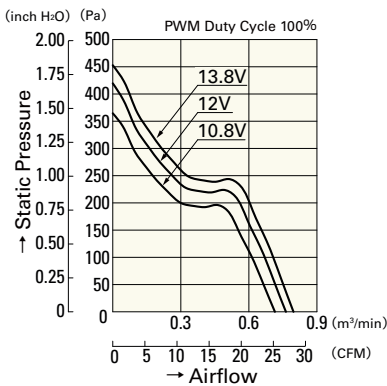

9GE0412P3K03

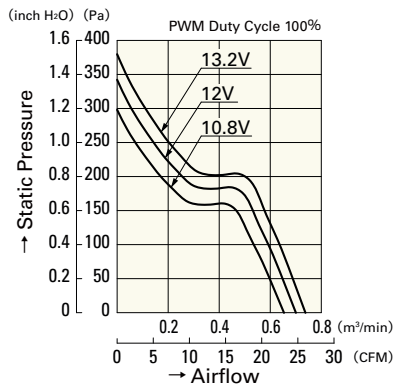

9GE0412P3J03

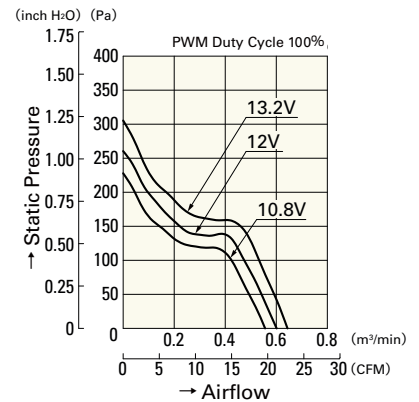

9GE0412P3G03

PWM Duty - Speed Characteristics Example

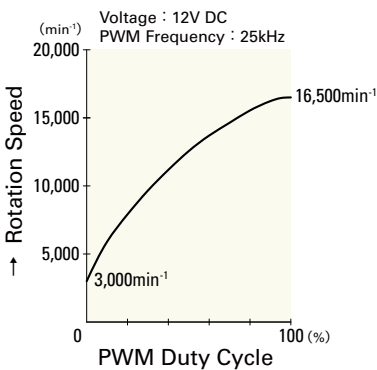

9GE0412P3K03

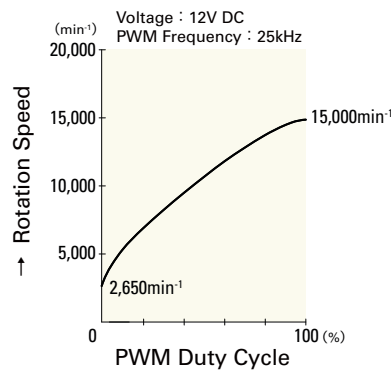

9GE0412P3J03

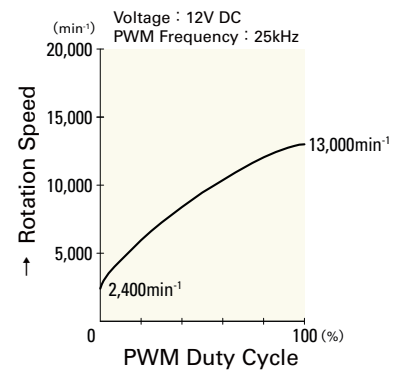

9GE0412P3G03