

# Solid State Relay

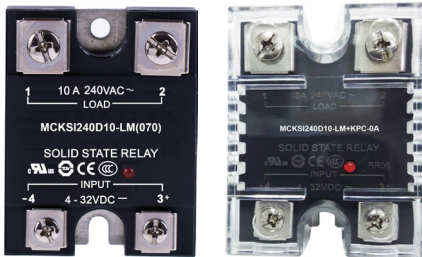

RoHS  
Compliant



## Description

The product is an industrial single phase relay with SCR output is widely used in many industrial applications. The relay can be used for resistive, inductive or capacitive load. The control input voltage is 4-32VDC . The output current is rated at 10A, 25A @ 48-280V AC.

## Features

- Zero Switching or Random-on Switching
- Ratings from 10A to 25A @ 48-280V AC
- SCR Output
- DC Input
- Superior Thermal Performance
- Dielectric Strength 4000VACrms
- MOV Protection Circuit as Optional

## Applications

Suitable for high-low temperature chamber, plastics machinery, incubation machine, oiling machine, HVAC, elevator lighting, fountain controller.

## Technical Specification

### Input Circuit

Control Voltage Range	: 4V DC to 32V DC
Min. Turn-On Voltage	: 4V DC
Min. Turn-Off Voltage	: 1V DC
Max. Input Current	: 25mA

### Output Circuit

Load Voltage	: 48 ~ 280V AC
Turn-on Time	: 10ms
Max. Turn-off Time	: 10ms
Max. Surge Current [@10ms]	
10A	: 100A
25A	: 250A
Max. I <sup>2</sup> t For Fusing [@10ms]	
10A	: 50A <sup>2</sup> S
25A	: 312A <sup>2</sup> S



# Solid State Relay



Transient Over Voltage : 600Vpk  
 Max. Off-State Leakage Current [@ Rated Voltage] : 5mA  
 Max. On-state Voltage Drop [@ Rated Current] : 1.5Vrms  
 Min. Off-state dv/dt [@ Max. Rated Voltage] : 500V/μs

## General Information

Dielectric Strength (50/60Hz)  
 Input/Output : 4000Vrms  
 Input, Output/Base : 2500Vrms  
 Ambient Operating Temperature Range : -30°C to +80°C  
 Ambient Storage Temperature Range : -30°C to +100°C  
 Weight (Typical) (Quick Connection Terminal) : 96g

## Diagram

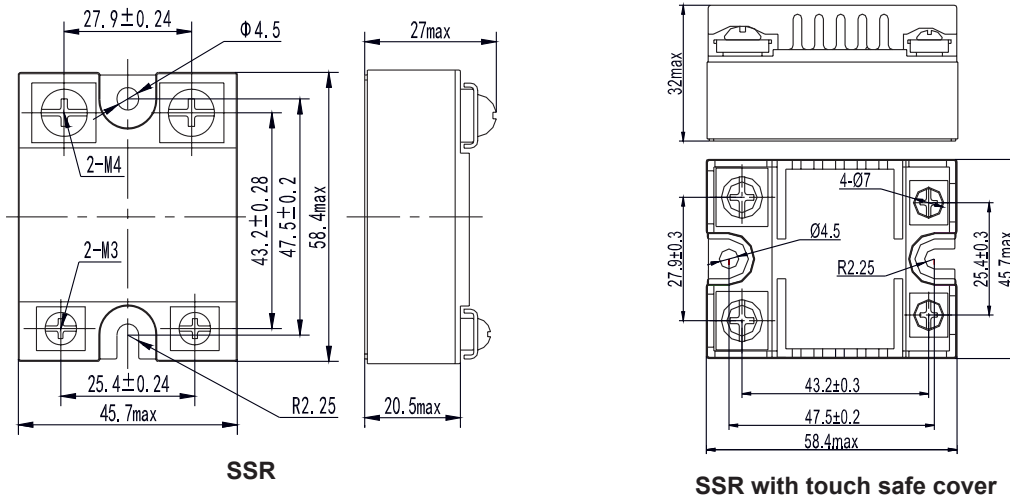

SSR

SSR with touch safe cover

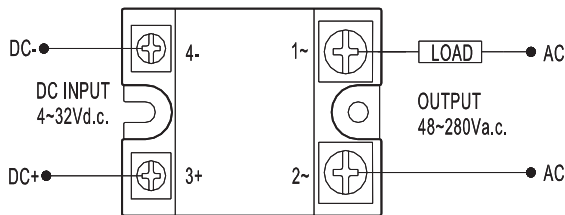

## Thermal Curve

Dimensions : Millimetres

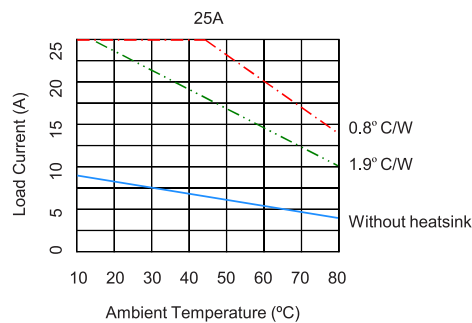
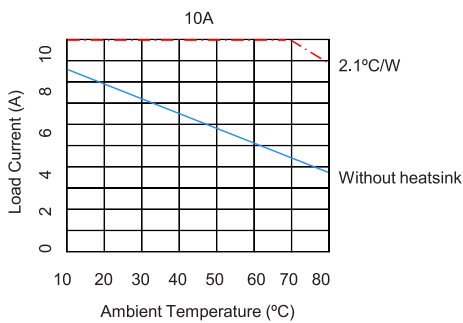

# Solid State Relay



## Part Number Explanation

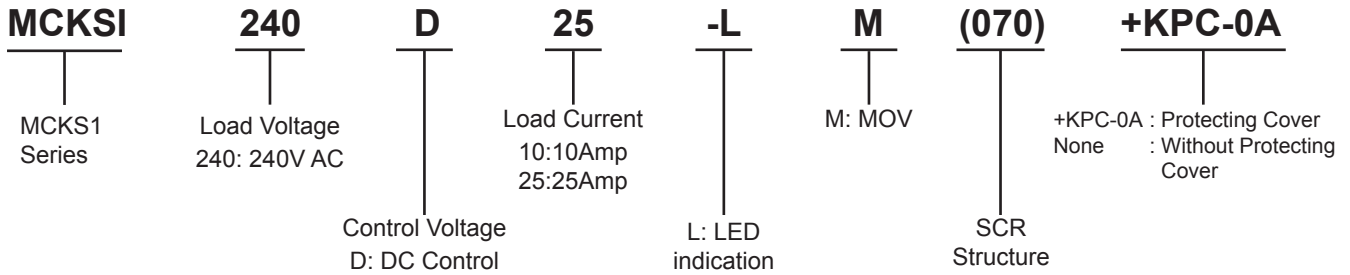

## Part Number Table

Description	Part Number
SSR, 10A, 48-280V AC, 4-32V DC	MCKSI240D10-LM(070)
SSR, 10A, 48-280V AC, 4-32VDC	MCKSI240D10-LM+KPC-0A
SSR, 25A, 48-280V AC, 4-32V DC	MCKSI240D25-LM(070)
SSR, 25A, 48-280V AC, 4-32V DC	MCKSI240D25-LM(070)+KPC-0A

**Important Notice :** This data sheet and its contents (the "Information") belong to the members of the Premier Farnell group of companies (the "Group") or are licensed to it. No licence is granted for the use of it other than for information purposes in connection with the products to which it relates. No licence of any intellectual property rights is granted. The Information is subject to change without notice and replaces all data sheets previously supplied. The Information supplied is believed to be accurate but the Group assumes no responsibility for its accuracy or completeness, any error in or omission from it or for any use made of it. Users of this data sheet should check for themselves the Information and the suitability of the products for their purpose and not make any assumptions based on information included or omitted. Liability for loss or damage resulting from any reliance on the Information or use of it (including liability resulting from negligence or where the Group was aware of the possibility of such loss or damage arising) is excluded. This will not operate to limit or restrict the Group's liability for death or personal injury resulting from its negligence. Multicomp is the registered trademark of the Group. © Premier Farnell Limited 2016.

