

ALUMINUM ELECTROLYTIC CAPACITORS

LNx

Screw Terminal Type, 85°C
High ripple longer life.



LQR



LNx

Long life LNY



- Suited for use in industrial power supplies for inverter circuitry, etc.
- High ripple current, extra-high voltage application.
- High reliability, long life for 20,000 hours application of rated ripple current at +85°C.
- Extended range up to φ100 × 250L size.
- Flame retardant electrolyte type available.
- Compliant to the RoHS directive (2011/65/EU).

Specifications

Item	Performance Characteristics						
Category Temperature Range	- 25 to +85°C						
Rated Voltage Range	350 to 630V						
Rated Capacitance Range	1000 to 27000μF						
Capacitance Tolerance	±20% at 120Hz, 20°C						
Leakage Current	After 5 minutes' application of rated voltage, leakage current is not more than $3\sqrt{CV}$ (μA) or 5 mA, whichever is smaller (at 20°C). [C: Rated Capacitance(μF), V: Voltage (V)]						
Tangent of loss angle (tan δ)	See refer to next page (Measurement frequency : 120Hz at 20°C)						
Stability at Low Temperature	<table border="1"> <tr> <td>Rated voltage (V)</td> <td>350 to 630</td> <td rowspan="2">Measurement frequency : 120Hz</td> </tr> <tr> <td>Impedance ratio ZT/Z20(MAX.)</td> <td>Z - 25°C / Z + 20°C</td> </tr> </table>	Rated voltage (V)	350 to 630	Measurement frequency : 120Hz	Impedance ratio ZT/Z20(MAX.)	Z - 25°C / Z + 20°C	
	Rated voltage (V)	350 to 630	Measurement frequency : 120Hz				
Impedance ratio ZT/Z20(MAX.)	Z - 25°C / Z + 20°C						
Endurance	<p>The specifications listed at right shall be met when the capacitors are restored to 20°C after the standard ripple current is applied for 20000 hours at 85°C, the peak voltage shall not exceed the rated voltage.(2000 hours at 85°C for the parts rated at 630V, 5000 hours at 85°C for the parts rated at 500V and 550V)</p> <p>The specifications listed at right shall be met when the capacitors are restored to 20°C after D.C. bias plus rated ripple current is applied for 5000 hours at 85°C, the peak voltage shall not exceed the rated voltage.</p> <table border="1"> <tr> <td>Capacitance change</td> <td>Within ±20% of the initial capacitance value</td> </tr> <tr> <td>tan δ</td> <td>300% or less than the initial specified value</td> </tr> <tr> <td>Leakage current</td> <td>Less than or equal to the initial specified value</td> </tr> </table>	Capacitance change	Within ±20% of the initial capacitance value	tan δ	300% or less than the initial specified value	Leakage current	Less than or equal to the initial specified value
	Capacitance change	Within ±20% of the initial capacitance value					
tan δ	300% or less than the initial specified value						
Leakage current	Less than or equal to the initial specified value						
Shelf Life	After storing the capacitors under no load at 85°C for 1000 hours and then performing voltage treatment based on JIS C 5101-4 clause 4.1 at 20°C, they shall meet the specified values for the endurance characteristics listed above.						
Marking	Printed with white color letter on black sleeve.						

Drawing

Method mount metal bracket

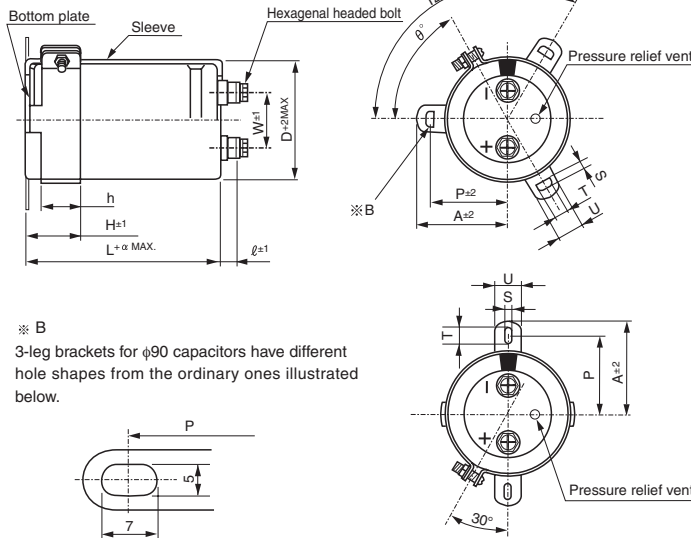

※ B
3-leg brackets for φ90 capacitors have different hole shapes from the ordinary ones illustrated below.



Type numbering system (Example : 450V 2200μF)

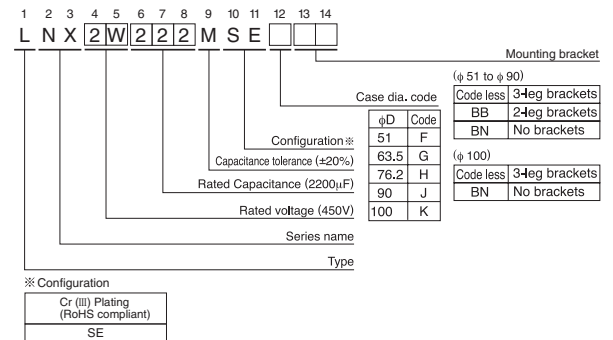

Please refer to page 324 for schematic of dimensions.
※ Please contact to us if PVCless products are required.

Dimension of terminal pitch (W) and length (ℓ) and Nominal dia. of bolt (mm)

φD	W	ℓ	α	Nominal dia. of bolt
51	22.0	6	3	M5
63.5	28.6	6	3	M5
76.2	31.8	6	3	M5
90	31.8	6	3	M5
100	41.5	10	4	M8

Dimensions of mounting bracket (mm)

Symbol	Leg shape	3-Leg				2-Leg				
		51	63.5	76.2	90	100	51	63.5	76.2	90
P	φD	32.5	38.1	44.5	50.8	56.3	33.2	40.5	46.5	53
A		38.5	43	49.2	58.5	62	40	46.5	53	59
T		7.5	8.0	7.0	8.0	8.0	6.0	7.0	6.0	6.0
S		5.0	5.0	5.0	5.0	5.0	4.5	4.5	4.5	4.5
U		12	14	14	18	16	14	14	14	14
θ°		60	60	60	60	60	30	30	30	30
H		20	25	30	35	36	25	35	35	35
h		15	20	24	25	30	15	20	20	20

● Dimension table in next page.

LNx

■ Dimensions

350V (2V)						
Cap. (μF)	Size φD × L(mm)	Standard ripple (Arms) ^{*1}	Rated ripple (Arms) ^{*2}	tan δ	Leakage Current (mA)	Code
1000	51 × 60	3.5	4.6	0.2	1.77	LNx2V102MSEF
1200	51 × 70	4.2	5.3	0.2	1.94	LNx2V122MSEF
1500	51 × 80	4.9	6.3	0.2	2.17	LNx2V152MSEF
1800	51 × 90	5.6	7.3	0.2	2.38	LNx2V182MSEF
2200	51 × 110	6.7	8.8	0.2	2.63	LNx2V222MSEF
2700	51 × 130	8.0	10.3	0.2	2.91	LNx2V272MSEF
	63.5 × 90	7.7	9.9	0.2	2.91	LNx2V272MSEG
3300	51 × 150	9.2	12.1	0.2	3.22	LNx2V332MSEF
	63.5 × 100	9.0	11.8	0.2	3.22	LNx2V332MSEG
3900	63.5 × 110	10.4	12.5	0.2	3.50	LNx2V392MSEG
	76.2 × 90	10.3	12.2	0.2	3.50	LNx2V392MSEH
4700	63.5 × 130	12.0	14.8	0.2	3.84	LNx2V472MSEG
	76.2 × 100	11.9	14.0	0.2	3.84	LNx2V472MSEH
5600	63.5 × 150	14.0	17.0	0.2	4.20	LNx2V562MSEG
	76.2 × 110	13.5	16.4	0.2	4.20	LNx2V562MSEH
6800	63.5 × 170	16.3	19.6	0.2	4.62	LNx2V682MSEG
	76.2 × 130	16.0	19.1	0.2	4.62	LNx2V682MSEH
8200	76.2 × 150	18.7	22.0	0.2	5.00	LNx2V822MSEH
	90 × 130	18.2	21.4	0.2	5.00	LNx2V822MSEJ
10000	76.2 × 170	21.8	25.5	0.2	5.00	LNx2V103MSEH
	90 × 150	21.3	25.3	0.2	5.00	LNx2V103MSEJ
12000	76.2 × 190	25.1	29.1	0.2	5.00	LNx2V123MSEH
	90 × 150	24.8	28.8	0.2	5.00	LNx2V123MSEJ
15000	90 × 190	29.0	36.0	0.2	5.00	LNx2V153MSEJ
18000	90 × 220	32.4	39.7	0.2	5.00	LNx2V183MSEJ
22000	100 × 220	38.0	43.2	0.2	5.00	LNx2V223MSEK
27000	100 × 250	42.0	47.0	0.2	5.00	LNx2V273MSEK

400V (2G)						
Cap. (μF)	Size φD × L(mm)	Standard ripple (Arms) ^{*1}	Rated ripple (Arms) ^{*2}	tan δ	Leakage Current (mA)	Code
1000	51 × 70	3.8	5.0	0.2	1.89	LNx2G102MSEF
1200	51 × 80	4.5	5.8	0.2	2.07	LNx2G122MSEF
1500	51 × 100	5.3	6.8	0.2	2.32	LNx2G152MSEF
1800	51 × 110	6.0	8.2	0.2	2.54	LNx2G182MSEF
2200	51 × 130	7.0	9.3	0.2	2.81	LNx2G222MSEF
	63.5 × 90	6.8	8.9	0.2	2.81	LNx2G222MSEG
2700	63.5 × 110	8.2	10.8	0.2	3.11	LNx2G272MSEG
	76.2 × 90	8.1	10.6	0.2	3.11	LNx2G272MSEH
3300	63.5 × 130	9.6	12.9	0.2	3.44	LNx2G332MSEG
	76.2 × 100	9.3	12.4	0.2	3.44	LNx2G332MSEH
3900	63.5 × 150	11.0	14.4	0.2	3.74	LNx2G392MSEG
	76.2 × 100	10.5	13.9	0.2	3.74	LNx2G392MSEH
4700	63.5 × 170	12.6	16.6	0.2	4.11	LNx2G472MSEG
	76.2 × 130	12.3	16.0	0.2	4.11	LNx2G472MSEH
5600	63.5 × 190	14.7	18.8	0.2	4.49	LNx2G562MSEG
	76.2 × 150	14.3	18.3	0.2	4.49	LNx2G562MSEH
6800	76.2 × 170	16.7	21.2	0.2	4.94	LNx2G682MSEH
	90 × 130	16.3	20.7	0.2	4.94	LNx2G682MSEJ
8200	76.2 × 190	19.3	24.1	0.2	5.00	LNx2G822MSEH
	90 × 150	19.0	23.7	0.2	5.00	LNx2G822MSEJ
10000	76.2 × 220	22.7	28.3	0.2	5.00	LNx2G103MSEH
	90 × 170	22.2	28.0	0.2	5.00	LNx2G103MSEJ
12000	90 × 190	25.5	31.9	0.2	5.00	LNx2G123MSEJ
15000	100 × 190	29.6	37.0	0.2	5.00	LNx2G153MSEK
18000	100 × 220	33.0	40.5	0.2	5.00	LNx2G183MSEK
22000	100 × 250	41.4	44.7	0.2	5.00	LNx2G223MSEK

450V (2W)						
Cap. (μF)	Size φD × L(mm)	Standard ripple (Arms) ^{*1}	Rated ripple (Arms) ^{*2}	tan δ	Leakage Current (mA)	Code
1000	51 × 80	4.0	5.2	0.2	2.01	LNx2W102MSEF
1200	51 × 100	4.7	6.3	0.2	2.20	LNx2W122MSEF
1500	51 × 110	5.4	7.3	0.2	2.46	LNx2W152MSEF
1800	51 × 130	6.4	8.7	0.2	2.70	LNx2W182MSEF
	63.5 × 90	6.1	7.6	0.2	2.70	LNx2W182MSEG
2200	63.5 × 110	7.2	9.6	0.2	2.98	LNx2W222MSEG
	76.2 × 90	7.1	9.4	0.2	2.98	LNx2W222MSEH
2700	63.5 × 130	8.6	11.3	0.2	3.30	LNx2W272MSEG
	76.2 × 100	8.3	11.0	0.2	3.30	LNx2W272MSEH
3300	63.5 × 150	10.0	13.3	0.2	3.65	LNx2W332MSEG
	76.2 × 110	9.7	12.9	0.2	3.65	LNx2W332MSEH
3900	63.5 × 170	11.4	15.1	0.2	3.97	LNx2W392MSEG
	76.2 × 130	11.2	14.6	0.2	3.97	LNx2W392MSEH
4700	63.5 × 190	13.0	17.3	0.2	4.36	LNx2W472MSEG
	76.2 × 150	12.9	16.9	0.2	4.36	LNx2W472MSEH
5600	76.2 × 170	15.4	19.4	0.2	4.76	LNx2W562MSEH
	90 × 150	15.3	19.1	0.2	4.76	LNx2W562MSEJ
6800	76.2 × 190	17.3	22.0	0.2	5.00	LNx2W682MSEH
	90 × 150	17.1	21.6	0.2	5.00	LNx2W682MSEJ
8200	76.2 × 220	20.3	25.7	0.2	5.00	LNx2W822MSEH
	90 × 170	19.8	25.4	0.2	5.00	LNx2W822MSEJ
10000	90 × 190	23.0	29.6	0.2	5.00	LNx2W103MSEJ
12000	90 × 220	26.9	33.5	0.2	5.00	LNx2W123MSEJ
15000	100 × 220	31.1	38.0	0.2	5.00	LNx2W153MSEK
18000	100 × 250	37.0	41.3	0.2	5.00	LNx2W183MSEK

500V (2H)						
Cap. (μF)	Size φD × L(mm)	Standard ripple (Arms) ^{*1}	Rated ripple (Arms) ^{*2}	tan δ	Leakage Current (mA)	Code
1000	51 × 110	4.2	—	0.2	2.12	LNx2H102MSEF
1200	63.5 × 90	4.8	—	0.2	2.32	LNx2H122MSEG
1500	63.5 × 90	5.5	—	0.2	2.59	LNx2H152MSEG
1800	63.5 × 110	6.5	—	0.2	2.84	LNx2H182MSEG
2200	63.5 × 130	7.7	—	0.2	3.14	LNx2H222MSEG
2700	76.2 × 110	8.8	—	0.2	3.48	LNx2H272MSEH
3300	76.2 × 130	10.4	—	0.2	3.85	LNx2H332MSEH
3900	76.2 × 150	12.1	—	0.2	4.18	LNx2H392MSEH
4700	90 × 130	13.7	—	0.2	4.59	LNx2H472MSEJ
5600	90 × 150	15.9	—	0.2	5.00	LNx2H562MSEJ
6800	90 × 170	18.5	—	0.2	5.00	LNx2H682MSEJ
8200	90 × 190	21.4	—	0.2	5.00	LNx2H822MSEJ
10000	100 × 190	23.8	—	0.2	5.00	LNx2H103MSEK
12000	100 × 220	27.8	—	0.2	5.00	LNx2H123MSEK

Ripple current (Arms) at 85°C 120Hz

LNx

■ Dimensions

550V (2L)						
Cap. (μF)	Size φD × L(mm)	Standard ripple (Arms) ^{*1}	Rated ripple (Arms) ^{*2}	tan δ	Leakage Current (mA)	Code
1000	51 × 130	4.3	—	0.2	2.22	LNx2L102MSEF
1200	63.5 × 110	5.0	—	0.2	2.43	LNx2L122MSEG
1500	63.5 × 130	6.0	—	0.2	2.72	LNx2L152MSEG
1800	76.2 × 110	6.7	—	0.2	2.98	LNx2L182MSEH
2200	76.2 × 130	8.0	—	0.2	3.30	LNx2L222MSEH
2700	76.2 × 150	9.4	—	0.2	3.65	LNx2L272MSEH
3300	76.2 × 170	11.0	—	0.2	4.04	LNx2L332MSEH
3900	90 × 150	12.5	—	0.2	4.39	LNx2L392MSEJ
4700	90 × 170	14.5	—	0.2	4.82	LNx2L472MSEJ
5600	90 × 190	16.6	—	0.2	5.00	LNx2L562MSEJ
6800	90 × 220	19.5	—	0.2	5.00	LNx2L682MSEJ
8200	100 × 220	21.6	—	0.2	5.00	LNx2L822MSEK
10000	100 × 250	25.2	—	0.2	5.00	LNx2L103MSEK

630V(2J)						
Cap. (μF)	Size φD × L(mm)	Standard ripple (Arms) ^{*1}	Rated ripple (Arms) ^{*2}	tan δ	Leakage Current (mA)	Code
1000	63.5 × 130	5.9	—	0.3	2.38	LNx2J102MSEG
1200	76.2 × 110	6.7	—	0.3	2.60	LNx2J122MSEH
1500	76.2 × 130	8.1	—	0.3	2.91	LNx2J152MSEH
1800	76.2 × 150	9.6	—	0.3	3.19	LNx2J182MSEH
2200	90 × 130	10.7	—	0.3	3.53	LNx2J222MSEJ
2700	90 × 150	12.6	—	0.3	3.91	LNx2J272MSEJ
3300	90 × 170	14.7	—	0.3	4.32	LNx2J332MSEJ
3900	90 × 190	17.3	—	0.3	4.70	LNx2J392MSEJ
4700	100 × 220	21.4	—	0.3	5.00	LNx2J472MSEK
5600	100 × 250	24.7	—	0.3	5.00	LNx2J562MSEK

Ripple current (Arms) at 85°C 120Hz

● Frequency coefficient of rated ripple current

Frequency (Hz)	50	60	120	360	1k	10k or more
Coefficient	0.80	0.82	1.00	1.20	1.35	1.40

- (※ 1) • Standard ripple current:
Ripple current value allowable for the life time of 20,000 hours at 85°C.
(5,000 hours at 85°C for the voltage rating of 500V and 550V. 2,000 hours at 85°C for the voltage rating of 630V)
- (※ 2) • Maximum rated ripple current:
Ripple current value allowable for the life time of 5,000 hours at 85°C.

- 3-leg bracket is furnished as standard.
In case no-bracket or 2-leg bracket required, please put BN or BB at the end of type number.

Ex. 3-leg bracket LNx2G472MSEH
2-leg bracket LNx2G472MSEHBB
No bracket LNx2G472MSEHBN

- Flame-retardant type electrolyte is also available.
Please contact to Nichicon representative for the rated ripple current value.