

## Safety relays - PSR-SCP- 24DC/ESD/4X1/30 - 2981800

Please be informed that the data shown in this PDF Document is generated from our Online Catalog. Please find the complete data in the user's documentation. Our General Terms of Use for Downloads are valid (<http://phoenixcontact.com/download>)



Safety relay for emergency stop and safety door monitoring up to SIL 3 or Cat. 4, PL e according to EN ISO 13849, automatic or manual activation, 2 N/O contacts with dropout delay of 0.1 s to 30 s, plug-in screw connection terminal block

### Why buy this product

- Maximum of 3 undelayed and 2 dropout delay contacts
- Manually monitored and automatic activation
- Up to Cat. 3/4 and PL d/e according to ISO 13849-1, SILCL 3 according to IEC 62061, SIL 3 according to IEC 61508
- For emergency stop and safety door monitoring, plus evaluation of light grids
- Single and two-channel control
- Fixed delay times of 0.1 s ... 300 s
- Protective labels to prevent manipulation of the set time (PSR-ESD-300) or electronic protection against manipulation (PSR-ESD-30)



### Key Commercial Data

Packing unit	1 STK
GTIN	 4 046356 117968
GTIN	4046356117968
Weight per Piece (excluding packing)	198.900 g
Custom tariff number	85371099
Country of origin	Germany

### Technical data

#### Note

Utilization restriction	EMC: class A product, see manufacturer's declaration in the download area
-------------------------	---

#### Dimensions

Width	22.5 mm
Height	99 mm

# Safety relays - PSR-SCP- 24DC/ESD/4X1/30 - 2981800

## Technical data

### Dimensions

Depth	114.5 mm
-------	----------

### Ambient conditions

Ambient temperature (operation)	-20 °C ... 45 °C
Ambient temperature (storage/transport)	-40 °C ... 70 °C
Max. permissible relative humidity (operation)	75 % (on average, 85% infrequently, non-condensing)
Max. permissible humidity (storage/transport)	75 % (on average, 85% infrequently, non-condensing)
Shock	15g
Vibration (operation)	10 Hz ... 150 Hz, 2g
Maximum altitude	≤ 2000 m (Above sea level)

### Input data

Nominal input voltage $U_N$	24 V DC
Input voltage range in reference to $U_N$	0.85 ... 1.1
Typical input current at $U_N$	75 mA DC
Voltage at input/start and feedback circuit	approx. 24 V DC
Typical response time	150 ms (Monitored/manual and auto-start)
Typical release time	20 ms (Undelayed contacts) 100 ms (delayed contacts)
Typical release time range	0.1 s ... 30 s
Recovery time	330 ms (Restart) 1 s (Electric torque)
Status display	LED K1/K2 and K3(t)/K4(t), green
Max. permissible overall conductor resistance	500 $\Omega$ (Input and reset circuit at $U_N$ )

### Output data

Contact type	4 enabling current paths
Contact material	AgSnO <sub>2</sub>
Minimum switching voltage	15 V AC/DC
Maximum switching voltage	250 V AC/DC
Limiting continuous current	6 A (N/O contact)
Inrush current, minimum	25 mA
Maximum inrush current	6 A
Sq. Total current	120 A <sup>2</sup> (see to derating)
Interrupting rating (ohmic load) max.	144 W (24 V DC, $\tau = 0$ ms) 288 W (48 V DC, $\tau = 0$ ms) 90 W (110 V DC, $\tau = 0$ ms) 88 W (220 V DC, $\tau = 0$ ms) 1500 VA (250 V AC, $\tau = 0$ ms)
Maximum interrupting rating (inductive load)	42 W (24 V DC, $\tau = 40$ ms) 33 W (48 V DC, $\tau = 40$ ms) 25 W (110 V DC, $\tau = 40$ ms)

## Safety relays - PSR-SCP- 24DC/ESD/4X1/30 - 2981800

### Technical data

#### Output data

	23 W (220 V DC, $\tau = 40$ ms)
Switching capacity min.	0.4 W
Output fuse	10 A gL/gG NEOZED (N/O contact)

#### General

Relay type	Electromechanical relay with forcibly guided contacts in accordance with EN 50205
Mechanical service life	Approx. $10^7$ cycles
Nominal operating mode	100% operating factor
Net weight	198.9 g
Mounting type	DIN rail mounting
Mounting position	any
Degree of protection	IP54
	IP20
Min. degree of protection of inst. location	IP54
Control	one and two channel

#### Connection data

Connection method	Screw connection
pluggable	Yes
Conductor cross section solid min.	0.2 mm <sup>2</sup>
Conductor cross section solid max.	2.5 mm <sup>2</sup>
Conductor cross section flexible min.	0.2 mm <sup>2</sup>
Conductor cross section flexible max.	2.5 mm <sup>2</sup>
Conductor cross section AWG min.	24
Conductor cross section AWG max.	12
Stripping length	7 mm
Screw thread	M3

#### Safety-related characteristic data

Stop category	0
	1
Safety Integrity Level (SIL)	3
Designation	EN ISO 13849
Performance level (PL)	e
Category	4
Safety Integrity Level Claim Limit (SIL CL)	3

#### Standards and Regulations

Shock	15g
Designation	Air clearances and creepage distances between the power circuits
Standards/regulations	DIN EN 60947-1
Rated insulation voltage	250 V

# Safety relays - PSR-SCP- 24DC/ESD/4X1/30 - 2981800

## Technical data

### Standards and Regulations

Rated surge voltage/insulation	4 kV / basic insulation
Degree of pollution	2
Overvoltage category	II
Vibration (operation)	10 Hz ...150 Hz, 2g

### Environmental Product Compliance

China RoHS	Environmentally Friendly Use Period = 50
	For details about hazardous substances go to tab "Downloads", Category "Manufacturer's declaration"

## Drawings

Circuit diagram

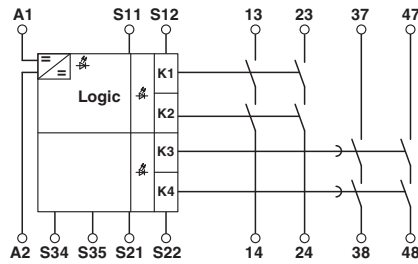

Circuit diagram

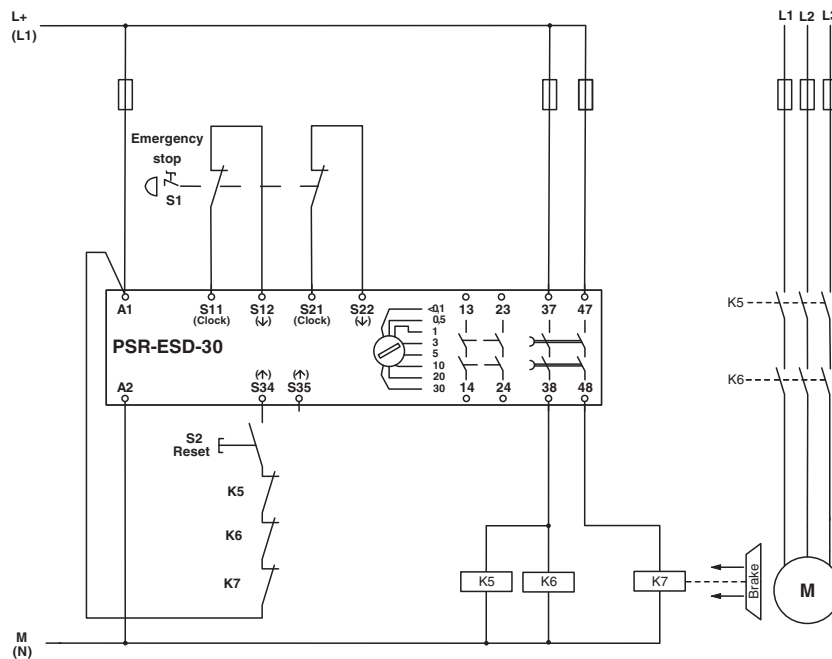

Two-channel emergency stop monitoring

# Safety relays - PSR-SCP- 24DC/ESD/4X1/30 - 2981800

Circuit diagram

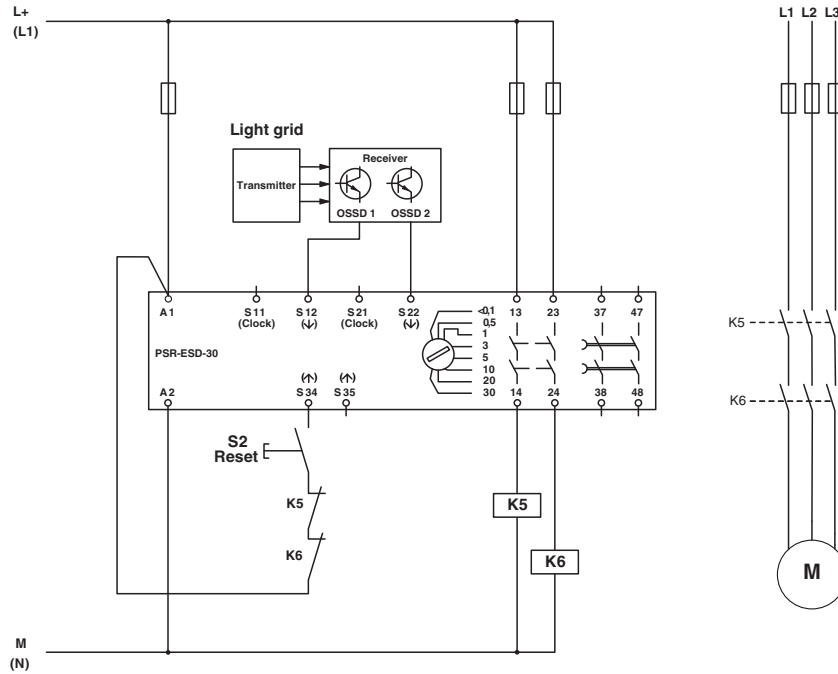

Light grid monitoring

Circuit diagram

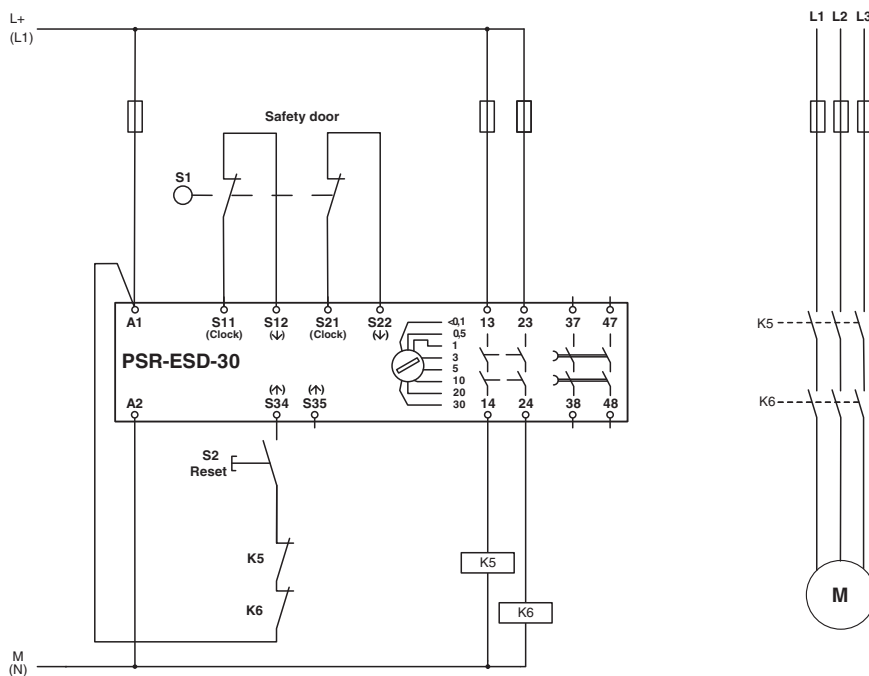

Two-channel safety door monitoring

## Safety relays - PSR-SCP- 24DC/ESD/4X1/30 - 2981800

### Classifications

#### eCl@ss

eCl@ss 4.0	27371102
eCl@ss 4.1	27371102
eCl@ss 5.0	27371901
eCl@ss 5.1	27371901
eCl@ss 6.0	27371819
eCl@ss 7.0	27371819
eCl@ss 8.0	27371819
eCl@ss 9.0	27371819

#### ETIM

ETIM 2.0	EC001449
ETIM 3.0	EC001449
ETIM 4.0	EC001449
ETIM 5.0	EC001449
ETIM 6.0	EC001449

#### UNSPSC

UNSPSC 6.01	30211901
UNSPSC 7.0901	39121501
UNSPSC 11	39121501
UNSPSC 12.01	39121501
UNSPSC 13.2	39121501

### Approvals

#### Approvals

#### Approvals

UL Listed / cUL Listed / Functional Safety / EAC / EAC / cULus Listed

#### Ex Approvals

#### Approval details

UL Listed		<a href="http://database.ul.com/cgi-bin/XYV/template/LISEXT/1FRAME/index.htm">http://database.ul.com/cgi-bin/XYV/template/LISEXT/1FRAME/index.htm</a>	FILE E 140324
-----------	---	---	---------------

# Safety relays - PSR-SCP- 24DC/ESD/4X1/30 - 2981800

## Approvals

cUL Listed		<a href="http://database.ul.com/cgi-bin/XYV/template/LISEXT/1FRAME/index.htm">http://database.ul.com/cgi-bin/XYV/template/LISEXT/1FRAME/index.htm</a>	FILE E 140324
------------	--	---	---------------

Functional Safety			01/205/0656.01/15
-------------------	--	--	-------------------

EAC			EAC-Zulassung
-----	--	--	---------------

EAC			7500651.22.01.00244
-----	--	--	---------------------

cULus Listed			
--------------	--	--	--