

IO-Link master multi-port evaluation board based on L6360

Data brief

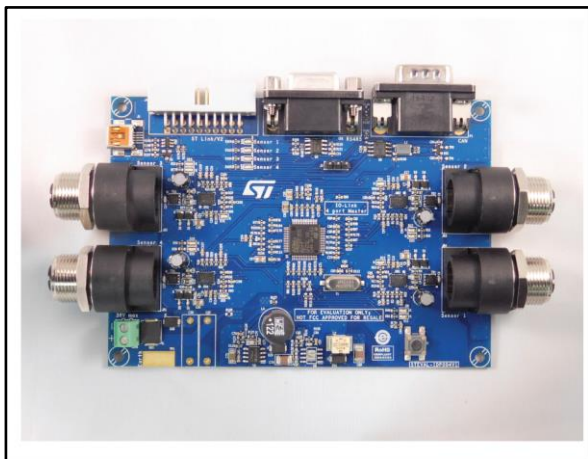

Features

- Main supply voltage 32 V maximum
- 4 L6360 IO-Link master device
- RS-485 serial interface
- CAN serial interface
- USB interface
- DC/DC converter
- On-board reverse polarity protection
- Designed to meet IEC requirement for industrial standards
- RoHS compliant

Description

The STEVAL-IDP004V1 evaluation board with STM32 microcontroller has four separate L6360 ICs.

Communication with the ICs is via I²C in master mode and is managed by the STM32F205RBT MCU; each L6360 has its own address and shares the bus with the other devices.

The STEVAL-IDP004V1 is developed to create a multi-port master d based on serial asynchronous communication to support the IO-Link protocol. Each node is equipped with an industrial M12 connector (as required by the standard) for connection with a single slave node using a cable 20 meter long; the wire is a normal three-pole: one for the IO-Link bus, one for the L+ line (positive supply voltage pole) and one for the L-line (negative supply voltage pole).

Beyond the IO-Link connection, the board includes RS485 bus, CAN bus and USB hardware interfaces.

The layout is designed to meet the requirements for IEC61000-4-2/4/5 for industrial segment.

1 Block identification

Figure 1: STEVAL-IDP004V1 block identification

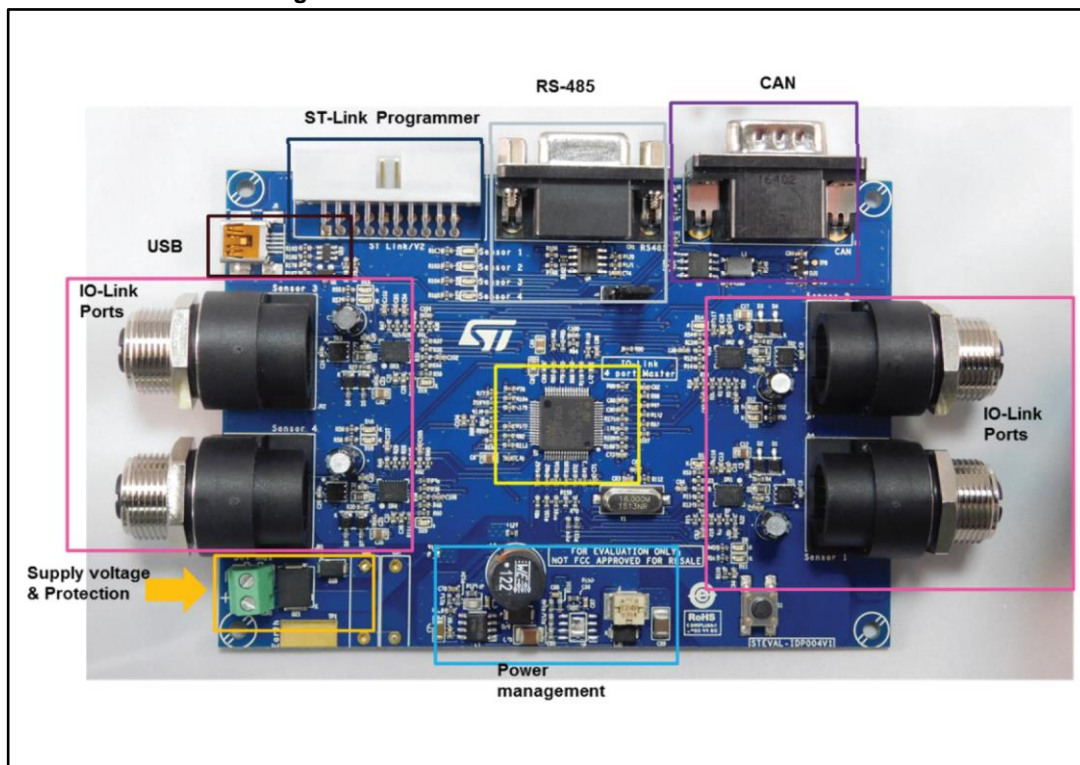

2 Schematic diagrams

Figure 2: STEVAL-IDP004V1 circuit schematic (1 of 11)

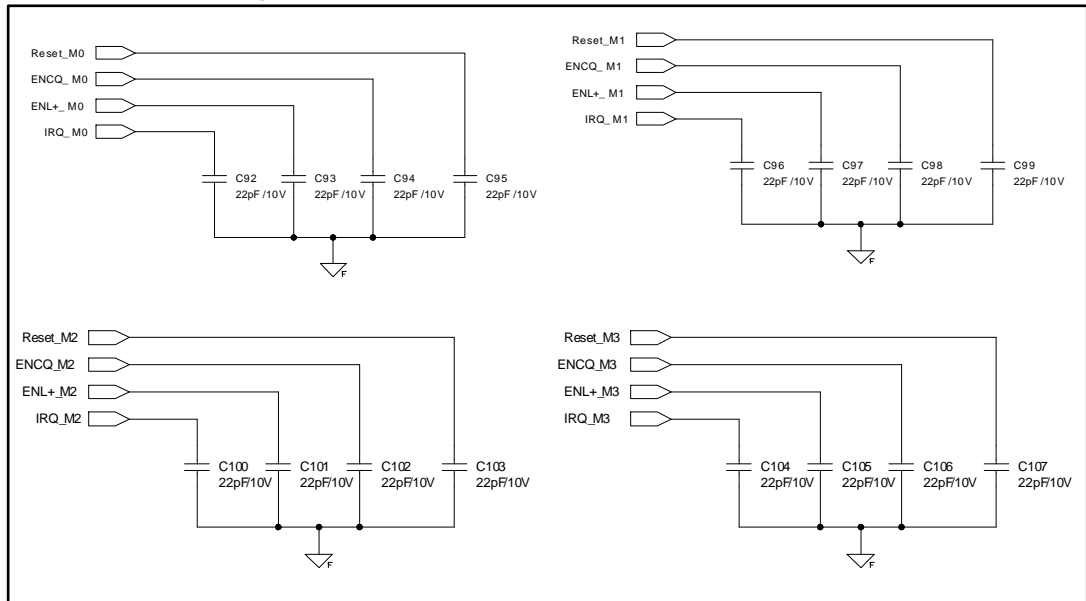

Figure 3: STEVAL-IDP004V1 circuit schematic (2 of 11)

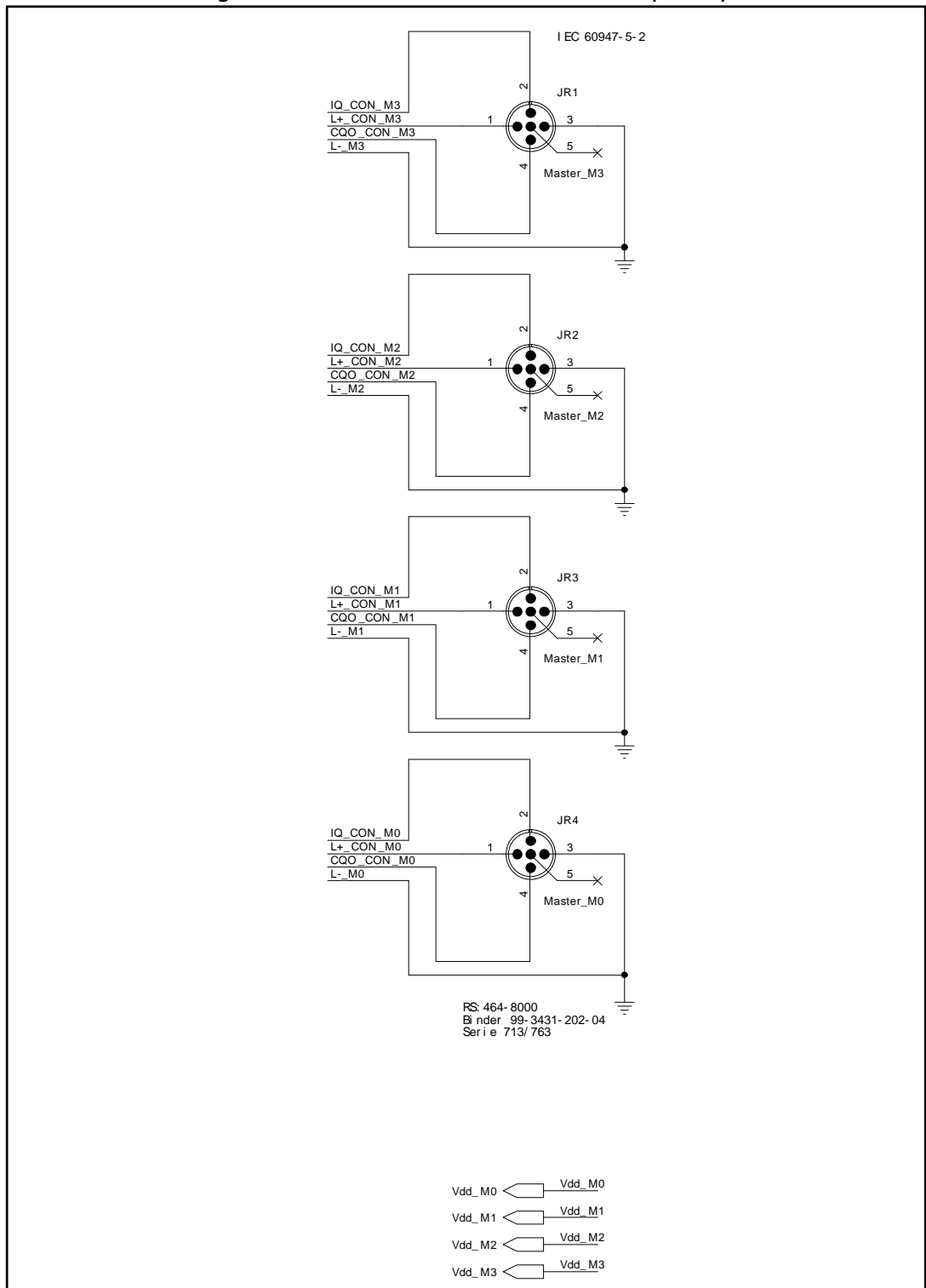

Figure 4: STEVAL-IDP004V1 circuit schematic (3 of 11)

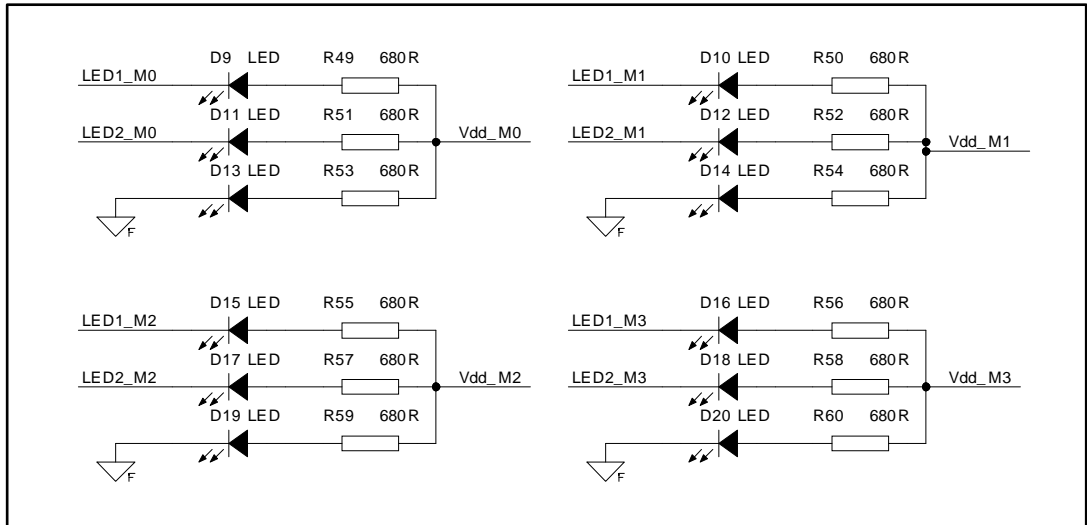

Figure 5: STEVAL-IDP004V1 circuit schematic (4 of 11)

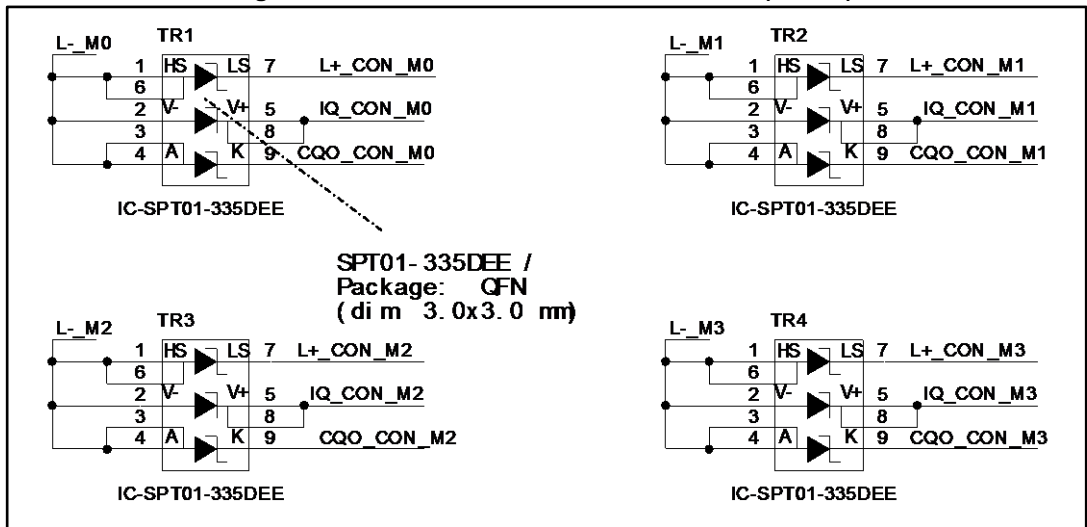

Figure 6: STEVAL-IDP004V1 circuit schematic (5 of 11)

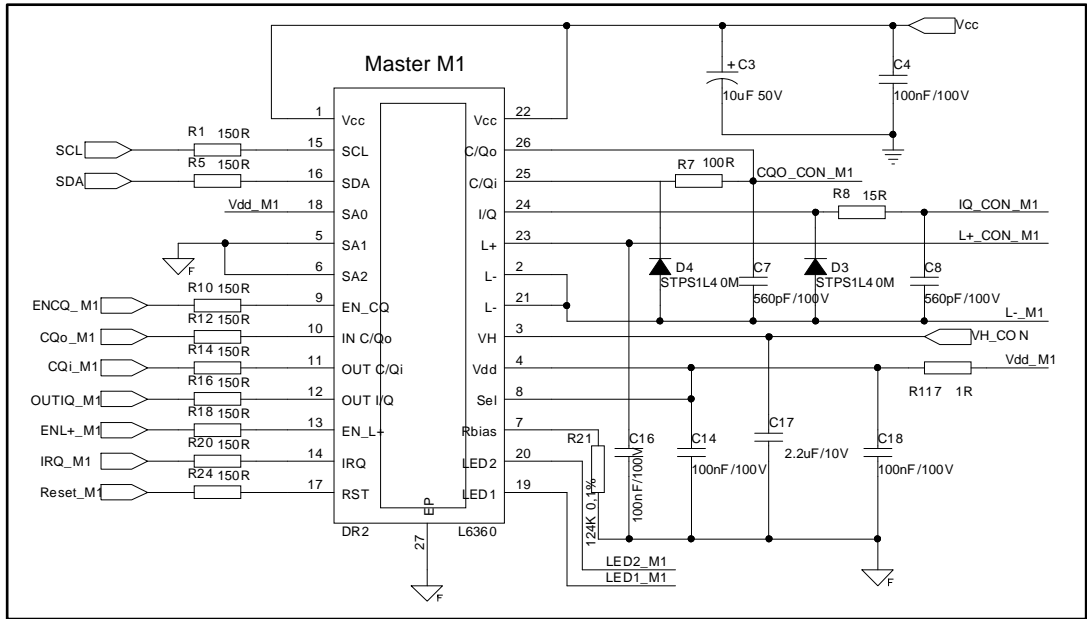

Figure 7: STEVAL-IDP004V1 circuit schematic (6 of 11)

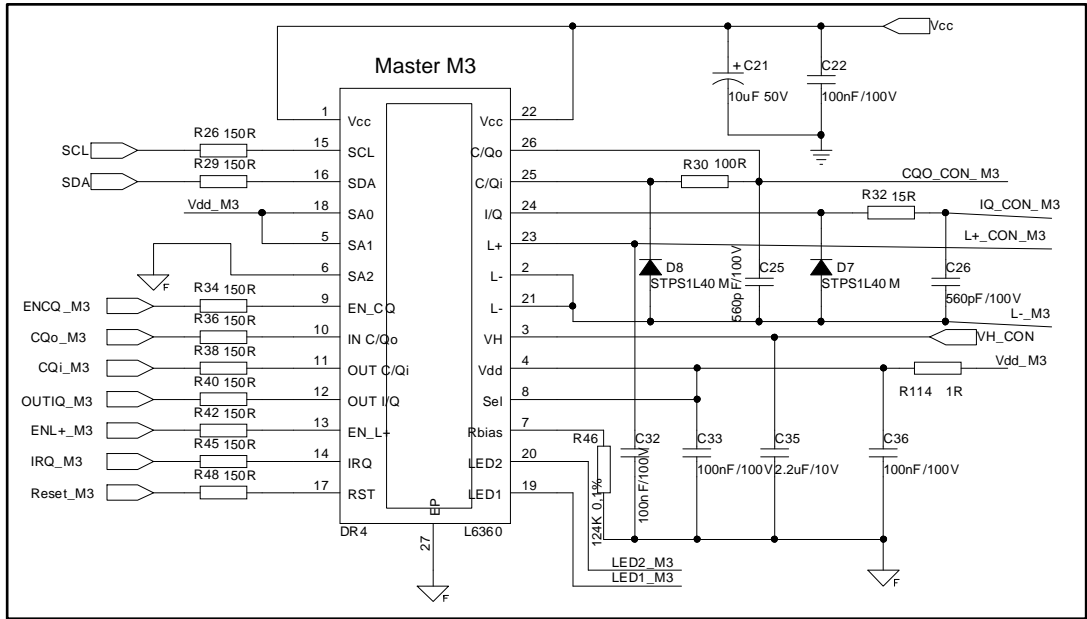

Figure 8: STEVAL-IDP004V1 circuit schematic (7 of 11)

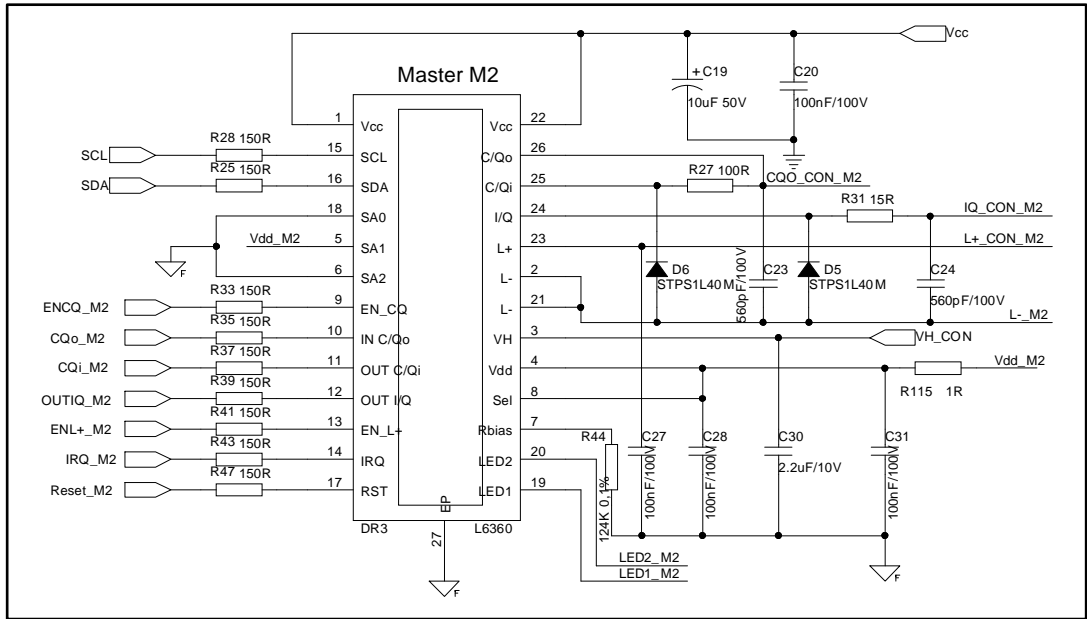

Figure 9: STEVAL-IDP004V1 circuit schematic (8 of 11)

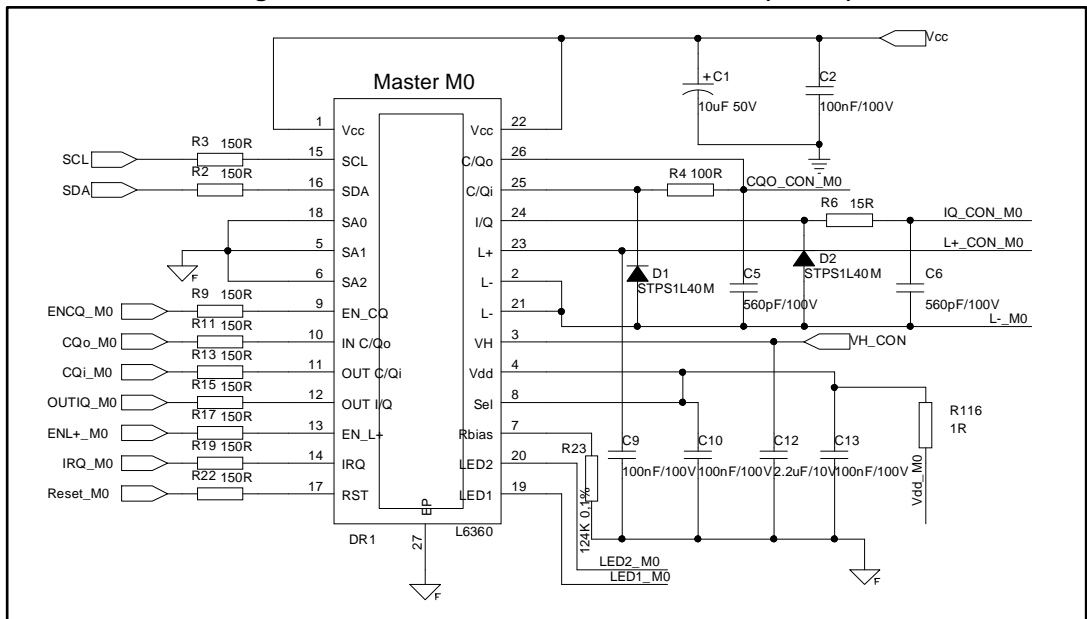

Figure 10: STEVAL-IDP004V1 circuit schematic (9 of 11)

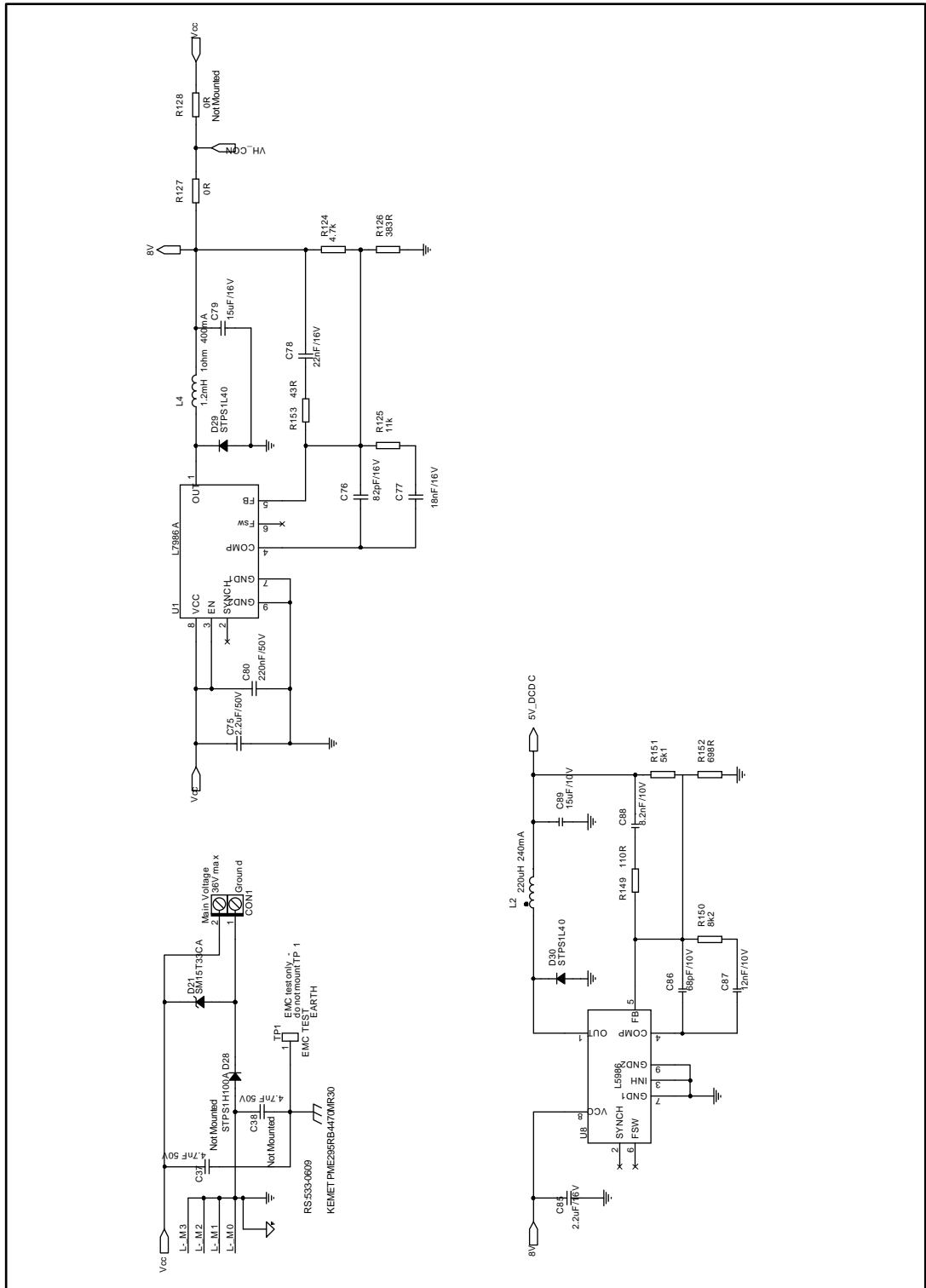

Figure 11: STEVAL-IDP004V1 circuit schematic (10 of 11)

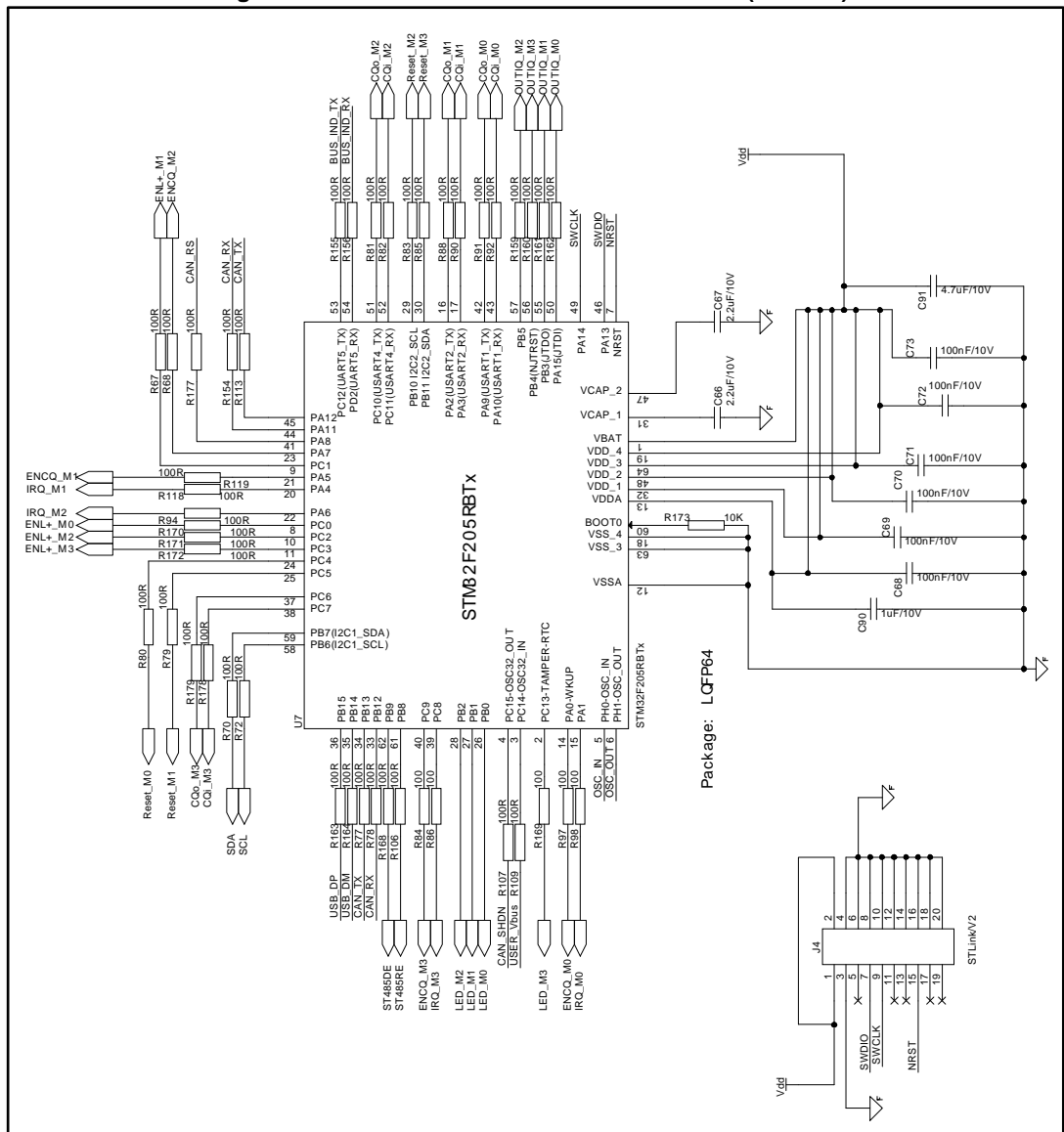
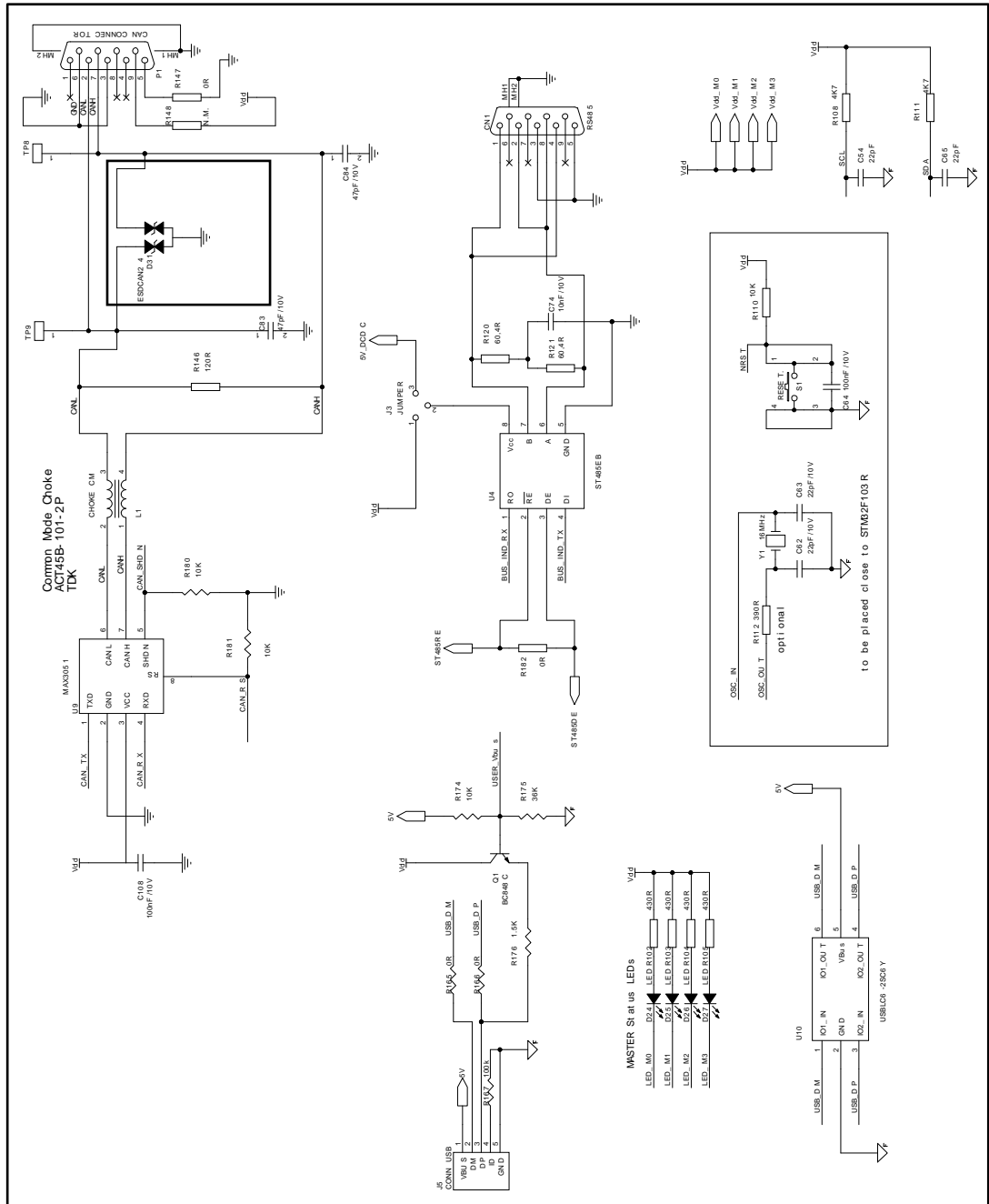

Figure 12: STEVAL-IDP004V1 circuit schematic (11 of 11)



3 Revision history

Table 1: Document revision history

Date	Version	Changes
17-May-2017	1	Initial release.
05-Jul-2017	2	Minor text changes.

IMPORTANT NOTICE – PLEASE READ CAREFULLY

STMicroelectronics NV and its subsidiaries ("ST") reserve the right to make changes, corrections, enhancements, modifications, and improvements to ST products and/or to this document at any time without notice. Purchasers should obtain the latest relevant information on ST products before placing orders. ST products are sold pursuant to ST's terms and conditions of sale in place at the time of order acknowledgement.

Purchasers are solely responsible for the choice, selection, and use of ST products and ST assumes no liability for application assistance or the design of Purchasers' products.

No license, express or implied, to any intellectual property right is granted by ST herein.

Resale of ST products with provisions different from the information set forth herein shall void any warranty granted by ST for such product.

ST and the ST logo are trademarks of ST. All other product or service names are the property of their respective owners.

Information in this document supersedes and replaces information previously supplied in any prior versions of this document.

© 2017 STMicroelectronics – All rights reserved