



Main

Range of product	Harmony XB6
Product or component type	Head for illuminated push-button
Product compatibility	Integral LED
Device short name	ZB6
Bezel material	Plastic
Mounting diameter	16 mm
Sale per indivisible quantity	1
Shape of signaling unit head	Round
Type of operator	Spring return
Operator profile	Green flush unmarked

Complementary

CAD overall width	18 mm
CAD overall height	18 mm
CAD overall depth	33 mm
Product weight	0.016 kg

Environment

Protective treatment	TC
Ambient air temperature for storage	-40...70 °C
Ambient air temperature for operation	-25...70 °C
Class of protection against electric shock	Class II conforming to IEC 61140
IP degree of protection	IP65 conforming to IEC 60529
NEMA degree of protection	NEMA 4 conforming to CSA C22.2 No 94 NEMA 13 conforming to CSA C22.2 No 94 NEMA 4X conforming to CSA C22.2 No 94 NEMA 13 conforming to UL 50 NEMA 4 conforming to UL 50

NEMA 4X conforming to UL 50

Standards	CSA C22.2 No 14 EN/IEC 60947-1 JIS C 852 UL 508 EN/IEC 60947-5-1 EN/IEC 60947-5-5 JIS C 4520
Product certifications	CSA UL CCC GOST
Vibration resistance	+/- 3 mm (f = 2...500 Hz) conforming to IEC 60068-2-6 5 gn (f = 2...500 Hz) conforming to IEC 60068-2-6
Shock resistance	30 gn (duration = 18 ms) for half sine wave acceleration conforming to IEC 60068-2-27 50 gn (duration = 11 ms) for half sine wave acceleration conforming to IEC 60068-2-27

Contractual warranty

Warranty period	18 months
-----------------	-----------

Circular Head for Illuminated or Non Illuminated Pushbutton

Dimensions

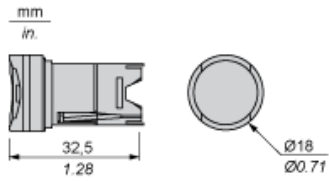

Panel Cut-out

For Square or Circular Head

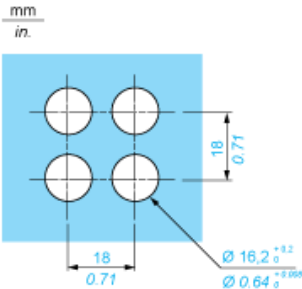

Pushbuttons, Switches and Pilot Lights for Printed Circuit Board Connection

Front Panel Cut-out (Viewed from Installer's Side)

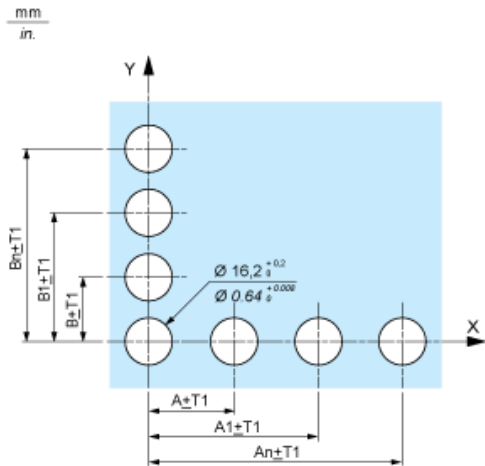

Printed Circuit Board Drillings (Viewed from Electrical Block Side)

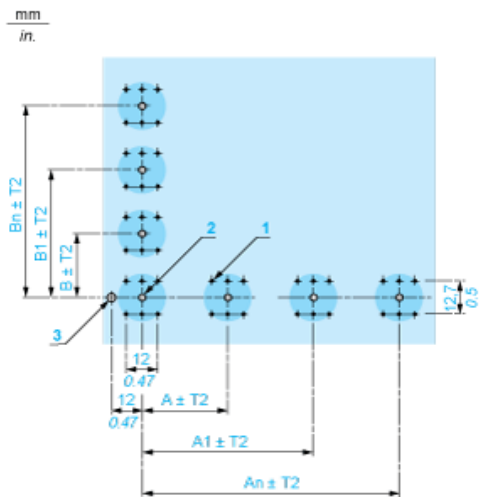

A 24 mm/0.94 in. minimum for rectangular heads, 18 mm/0.71 in. minimum for square or circular heads

B 18 mm/0.71 in. minimum

(1) 6 x Ø 1.1 mm / 6 x Ø 0.04 in. holes.

(2) 1 x Ø 2.6⁰_{-0,2} mm / 1 x Ø 0.10⁰_{-0,008} in. hole for locating pin, only when using socket adaptor ZB6Y010.

(3) 1 x Ø 3.2⁰_{-0,2} mm / 1 x Ø 0.13⁰_{-0,008} in. hole for fixing of printed circuit board onto the front panel using body bracket ZB6Y011. This hole must be drilled on the left-hand side, when head

General tolerances of the panel and printed circuit board: T1, T2: T1 + T2 = 0.3 mm/0.01 in. maximum.

Installation precautions:

Thickness of printed circuit board: 1.6 mm/0.06 in. minimum.

Mounting with Body Bracket

With socket adaptor ZB6Y010

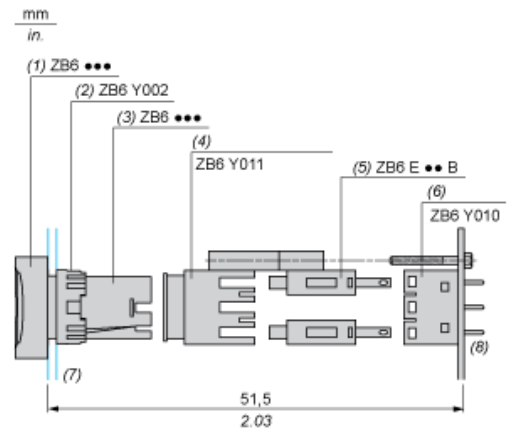

- (1) Head
- (2) Nut
- (3) Body
- (4) Body bracket
- (5) Contact block
- (6) Socket adaptor
- (7) Panel
- (8) Printed circuit

Direct mounting without socket adaptor ZB6Y010

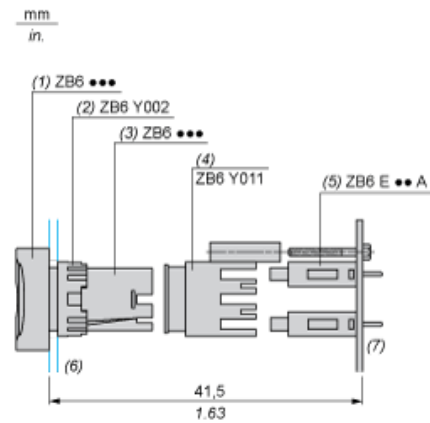

- (1) Head
- (2) Nut
- (3) Body
- (4) Body bracket
- (5) Contact block
- (6) Panel
- (7) Printed circuit