



Main

Range of product	Altistart 01
Product or component type	Soft starter
Product destination	Asynchronous motors
Product specific application	Simple machine
Device short name	ATS01
Network number of phases	1 phase
[Us] rated supply voltage	110...480 V - 10...10 %
Motor power kW	4 kW 3 phases 400 V 1.5 kW 3 phases 230 V 1.1 kW 1 phase 230 V
Motor power hp	1 hp 3 phases 210 V 2 hp 3 phases 230 V 5 hp 3 phases 460 V
IcL starter rating	9 A
Utilisation category	AC-53B EN/IEC 60947-4-2
Current consumption	45 A at nominal load
Type of start	Start with voltage ramp
Power dissipation in W	1 W at full load and at end of starting 46 W in transient state

Complementary

Assembly style	With heat sink
Function available	Integrated bypass
Supply voltage limits	99...528 V
Supply frequency	50...60 Hz - 5...5 %
Network frequency	47.5...63 Hz
Output voltage	<= power supply voltage
Control circuit voltage	24 V AC/DC +/- 10 % 30 mA 110 V AC +/- 10 % 35 mA

	240 V AC +/- 10 % 80 mA
Starting time	1 s 100 5 s 20 Adjustable from 1 to 5 s
Starting torque	30...80 % of starting torque of motor connected directly on the line supply
Discrete output current	2 A DC-13 3 A AC-15
Tightening torque	1.9...2.5 N.m 0.5 N.m
Electrical connection	4 mm screw clamp terminal rigid 1 1...10 mm ² AWG 8 power circuit Screw connector rigid 1 0.5...2.5 mm ² AWG 14 control circuit 4 mm screw clamp terminal rigid 2 1...6 mm ² AWG 10 power circuit Screw connector rigid 2 0.5...1 mm ² AWG 17 control circuit Screw connector flexible with cable end 1 0.5...1.5 mm ² AWG 16 control circuit 4 mm screw clamp terminal flexible without cable end 1 1.5...10 mm ² AWG 8 power circuit Screw connector flexible without cable end 1 0.5...2.5 mm ² AWG 14 control circuit 4 mm screw clamp terminal flexible with cable end 2 1...6 mm ² AWG 10 power circuit 4 mm screw clamp terminal flexible without cable end 2 1.5...6 mm ² AWG 10 power circuit Screw connector flexible without cable end 2 0.5...1.5 mm ² AWG 16 control circuit
Marking	CE
Operating position	Vertical +/- 10 degree
Height	124 mm
Width	45 mm
Depth	131 mm
Product weight	0.28 kg
Compatibility code	ATS01N1
Motor power range AC-3	1.1...2 kW at 200...240 V 1 phase 2.2...3 kW at 200...240 V 3 phases 4...6 kW at 380...440 V 3 phases
Motor starter type	Soft starter

Environment

Electromagnetic compatibility	Damped oscillating waves level 3 IEC 61000-4-12 Electrostatic discharge level 3 IEC 61000-4-2 Immunity to electrical transients level 4 IEC 61000-4-4 Immunity to radiated radio-electrical interference level 3 IEC 61000-4-3 Voltage/Current impulse level 3 IEC 61000-4-5 Conducted and radiated emissions level B CISPR 11 Conducted and radiated emissions level B IEC 60947-4-2 EMC immunity EN 50082-2 Harmonics IEC 1000-3-2 Harmonics IEC 1000-3-4 Immunity to conducted interference caused by radio-electrical fields level 3 IEC 61000-4-6 Micro-cuts and voltage fluctuation IEC 61000-4-11 EMC immunity EN 50082-1
Standards	EN/IEC 60947-4-2
Product certifications	CCC C-Tick B44.1-96/ASME A17.5 for starter wired to the motor delta terminal GOST CSA UL
IP degree of protection	IP20
Pollution degree	2 EN/IEC 60947-4-2
Vibration resistance	1.5 mm peak to peak 3...13 Hz EN/IEC 60068-2-6 1 gn 13...150 Hz EN/IEC 60068-2-6
Shock resistance	15 gn 11 ms EN/IEC 60068-2-27
Relative humidity	5...95 % without condensation or dripping water EN/IEC 60068-2-3
Ambient air temperature for operation	-10...40 °C without derating 40...50 °C with current derating of 2 % per °C
Ambient air temperature for storage	-25...70 °C EN/IEC 60947-4-2
Operating altitude	<= 1000 m without derating > 1000 m with current derating of 2.2 % per additional 100 m

Contractual warranty

Warranty period	18 months
-----------------	-----------

Dimensions

Mounting on Symetrical (35 mm) Rail

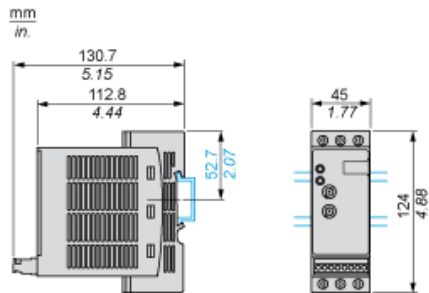

Screw Fixing

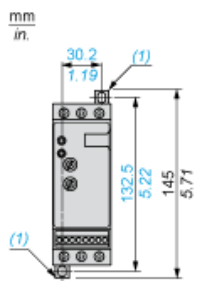

(1) Retractable fixings

Example of 3-phase Power Supply Connection

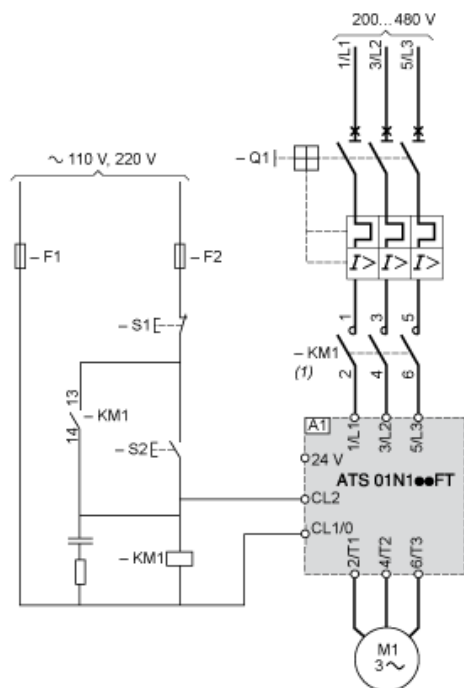

- (1) A line contactor must be used in the sequence.
A1 : Soft starter
Q1 : Motor circuit-breaker
KM1 : Contactors
F1, F2 : Control protection fuses
S1, S2 : Pushbuttons

Function Diagram

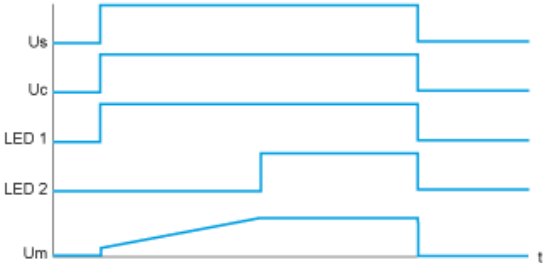

Us : Power supply voltage
Uc : Control supply voltage
LED 1 Green LED
LED 2 Yellow LED
Um : Motor voltage