



### Main

Range of product	Harmony XVB
Accessory / separate part designation	Fixing plate for mounting on a vertical surface
Accessory / separate part type	Fixing plate
Accessory / separate part category	Mounting and fixing accessories
Product compatibility	XVBC0. XVBC11
Accessory / separate part destination	Illuminated indicator bank
Colour	Black
Material	Zamak

### Complementary

Mounting support	On fixing base Direct mounting on base unit
Product weight	0.38 kg

### Contractual warranty

Warranty period	18 months
-----------------	-----------

Dimensions and Mounting

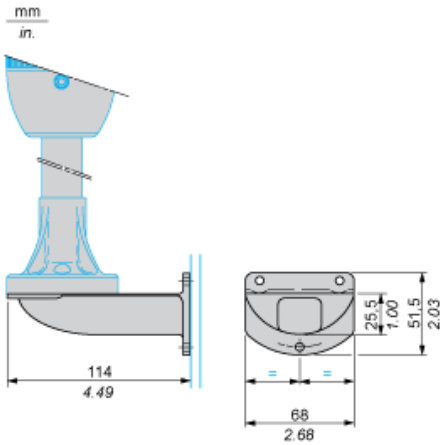

---

## Vertical Support Panel Drillings

---

