

EMH Series

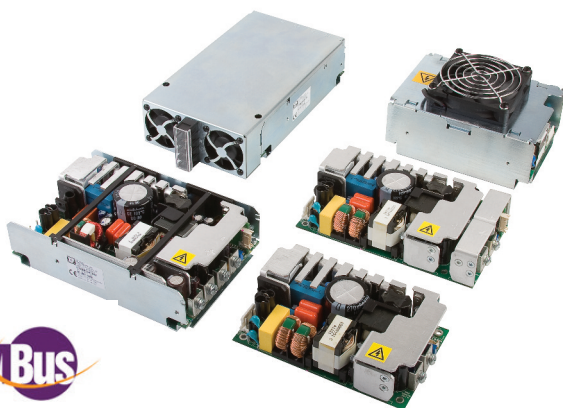

- Single & Dual Output Models
- IT & Medical (BF) Approvals
- 80 V – 275 VAC Operation
- Optional ORing Diode (EMH350D Models)
- Analog & PMBus Signals Options (EMH350)
- 5 V Standby (EMH350)
- 3 Year Warranty

Specification

Input

Input Voltage	• 80-275 VAC, derate output power <90 VAC (see derating curve)
Input Frequency	• 47-63 Hz
Input Current	• 2.6 / 3.6 A at 115 VAC typical (250 / 350 W) • 1.3 / 1.8 A at 230 VAC typical (250 / 350 W)
Inrush Current	• 40 A max at 230 VAC, cold start 25 °C
Power Factor	• >0.9
Earth Leakage Current	• 250 µA max, 264 VAC, 60 Hz
Patient Leakage Current	• 100 µA max
Input Protection	• 10 AF / 250 V internal fuse in line and neutral

Output

Output Voltage	• 12-48 VDC (see tables)
Output Voltage Trim	• ±10% V1
Initial Set Accuracy	• ±1% V1, ±5% V2
Minimum Load	• No minimum load required
Start Up Delay	• 1 s typical
Start Up Rise Time	• 50 ms
Hold Up Time	• 16 ms typical
Line Regulation	• ±0.5% maximum
Load Regulation	• ±1% V1, ±5% standby
Cross Regulation	• Dual output only (see regulation curves)
Transient Response	• 4% max. deviation, recovery to within 1% in 500 µs for a 50-75-50% load change
Ripple & Noise	• 1% pk-pk, 20 MHz bandwidth
Overvoltage Protection	• 115-140% V1 nom, recycle input to reset
Overtemperature Protection	• Auto reset
Overload Protection	• 110-150%, power limit
Short Circuit Protection	• Continuous, approximately constant current
Temperature Coefficient	• 0.05% /°C
Remote Sense	• Compensates for up to 0.5 V drop

General

Efficiency	• 87% typical
Isolation	• 4000 VAC input to output 2 x MOPP, 1500 VAC input to ground 1 x MOPP, 1500 VAC output to ground 1 x MOPP
Switching Frequency	• 62-560 / 71 / 50-130 KHz, PFC/Main/Standby Converter
Power Density	• 11.6/ 16.3/ 9.5 W/in ³ (250 / 350 / 350 W Dual)
Signals (Option EMH350)	• Power fail, Inhibit, 5V Standby, Current Share, fan speed control and I2C PMBus Options
MTBF	• 400 kHrs to MIL-HDBK-217F at 25 °C, GB

Environmental

Operating Temperature	• 0 °C to +70 °C, derate linearly from +50 °C at 2.5% / °C to 50% load at +70 °C
Cooling	• Forced cooled 12 CFM (350 W Dual: 16 CFM) or integral fan. See thermal considerations longform datasheet
Operating Humidity	• 95% RH, non-condensing
Storage Temperature	• -40 °C to +85 °C
Operating Altitude	• 3048 m
Shock	• ±3 x 30g shocks in each plane, total 18 shocks. 30g = 11 ms (±0.5 ms), half sine, conforms to EN60068-2-27 & EN60068-2-47
Vibration	• Single axis 10 - 500 Hz at 2g sweep and endurance at resonance in all 3 planes. Conforms to EN60068-2-6

EMC & Safety

Emissions	• EN55011/22 level B conducted • EN55011/22 level A radiated (See EMC report)
Harmonic Currents	• EN61000-3-2, class A
Voltage Flicker	• EN61000-3-3
Radiated Immunity	• EN61000-4-3, level 3 Perf Criteria A
EFT/Burst	• EN61000-4-4, level 3 Perf Criteria A
Surge	• EN61000-4-5, installation class 3, Perf Criteria A
Conducted Immunity	• EN61000-4-6, level 3, Perf Criteria A
Dips & Interruptions	• EN61000-4-11, 30% 10 ms, 60% 100 ms, 100% 5000 ms, Perf Criteria A, B, B, • EN60601-1-2, 30% 500 ms, 60% 100 ms, 100% 10 ms, 100% 5000 ms, Perf Criteria A, A, A, B - 230 VAC. Consult longform datasheet for 115 V operation.
Safety Approvals	• EN60601-1, ANSI/AAMI ES60601-1, CSA22.2 No.60601-1 per cUL BF Rated, Including Risk Management, EN60950, UL60950

Models and Ratings – Single Outputs

EMH250 XP

Output Voltage V1	Output Current V1	Fan Supply V3	Output Power	Model Number ⁽¹⁾
12 V	21.0 A	12 V/0.6 A	252 W	EMH250PS12
18 V	14.0 A	12 V/0.6 A	252 W	EMH250PS18
24 V	10.5 A	12 V/0.6 A	252 W	EMH250PS24
48 V	5.2 A	12 V/0.6 A	250 W	EMH250PS48

Notes

1. The EMH250 is available with a top mounted fan cover option. Add suffix '-TF' to model number e.g. EMH250PS12-TF. See mechanical drawing later in this datasheet.

Mechanical Details

EMH250PSXX

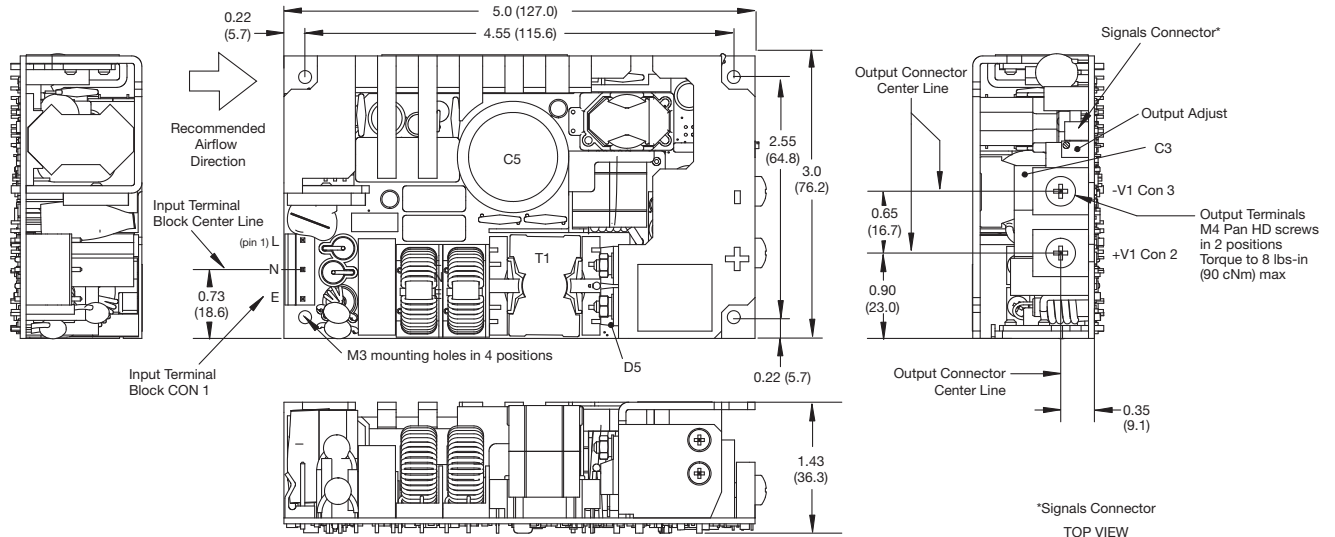

Input Connector CON 1 TYCO part # 640445-5	
Pin 1	Line
Pin 3	Neutral
Pin 5	Earth

Output Connector	
Con 2	+V1
Con 3	-V1

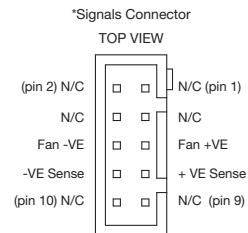

Signals Connector 10 way 2 mm pitch p/n JST B10B-PHDSS
Mating Half - p/n JST PHDR-10VS,
Contact- 26-22 AWG p/n JST SPHD-001T-P0.5

Pins 2 & 4 removed
Mates with Tyco SL-156 Series Connector

Notes

1. Dimensions shown in inches (mm).
Tolerance: ±0.02 (±0.5)

2. Weight: 0.90 lb (410 g).

Derating Curve – All EMH250 & EMH350 Models

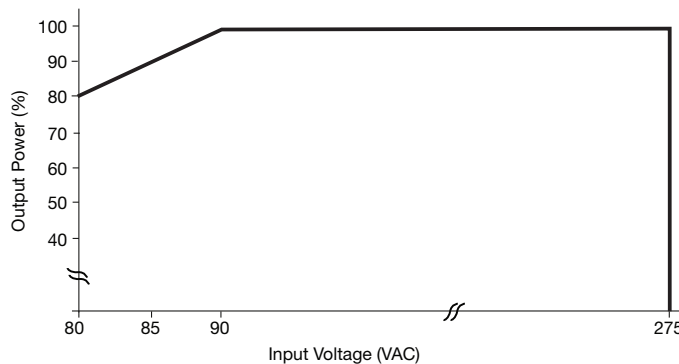

Models and Ratings - Single Outputs

Output Voltage V1	Output Current V1	Standby Supply	Fan Supply V3	Output Power	Model Number ⁽¹⁾
12 V	29.2 A	5.0V / 2.0 A	12V/0.6 A	354 W	EMH350PS12
18 V	19.5 A	5.0V / 2.0 A	12V/0.6 A	354 W	EMH350PS18
24 V	14.6 A	5.0V / 2.0 A	12V/0.6 A	355 W	EMH350PS24
48 V	7.3 A	5.0V / 2.0 A	12V/0.6 A	354 W	EMH350PS48

Notes

1. The EMH350 is available with various analog, digital signal and cover options. See compatibility table and mechanical drawing later in this datasheet.

Mechanical Details

EMH350

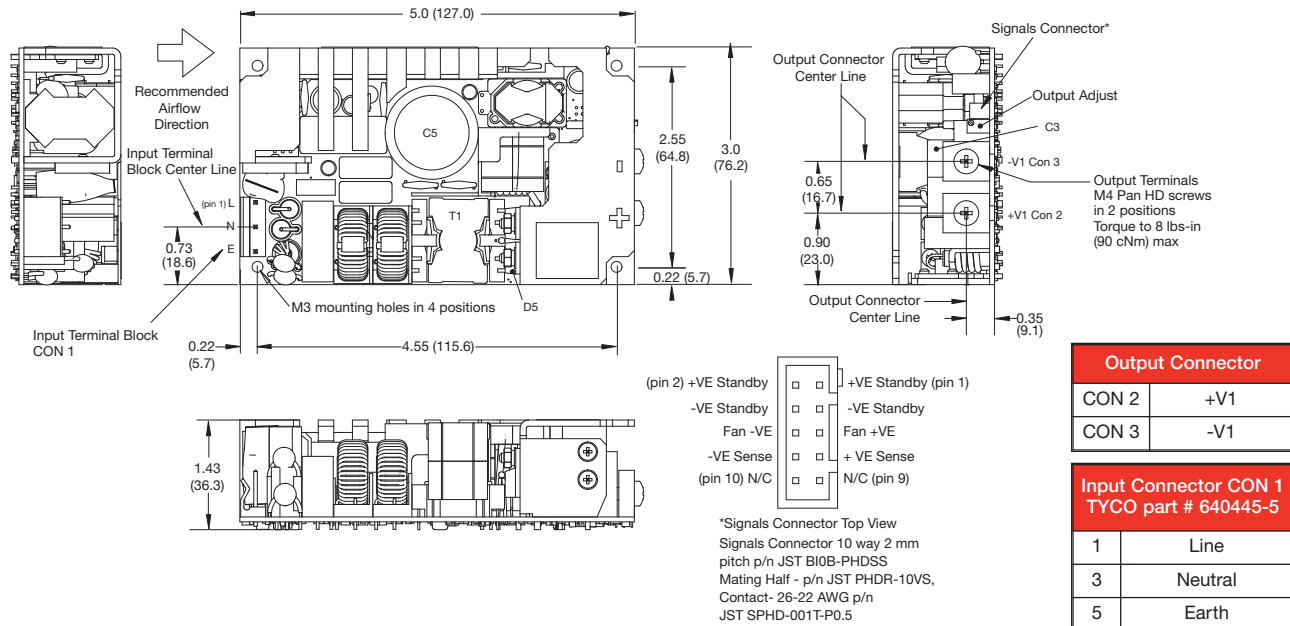

EMH350 (Signal Options)

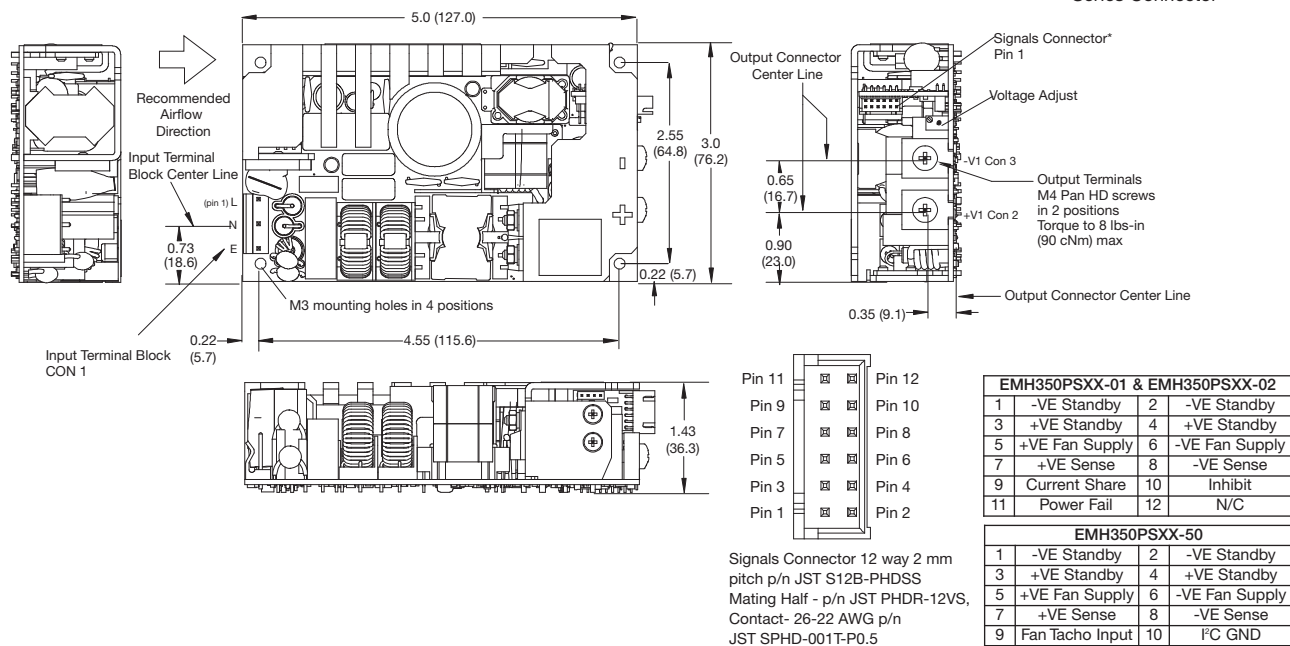

Notes

1. Dimensions shown in inches (mm). Tolerance: ±0.02 (±0.5)

2. Weight: 0.9 lb (410 g).

Models and Ratings - Single Outputs

EMH350D XP

Output Voltage V1	Output Current V1	Standby Supply	Fan Supply V3	Output Power	Model Number ⁽¹⁾
12 V	29.2 A	5.0V / 2.0 A	12V/0.6 A	354 W	EMH350PS12D
18 V	19.5 A	5.0V / 2.0 A	12V/0.6 A	354 W	EMH350PS18D
24 V	14.6 A	5.0V / 2.0 A	12V/0.6 A	355 W	EMH350PS24D
48 V	7.3 A	5.0V / 2.0 A	12V/0.6 A	354 W	EMH350PS48D

Notes

1. The EMH350D models are fitted with an integral ORing diode and are also available with various analog and digital signal options. See compatibility table and mechanical drawing later in this datasheet.

Mechanical Details

EMH350D

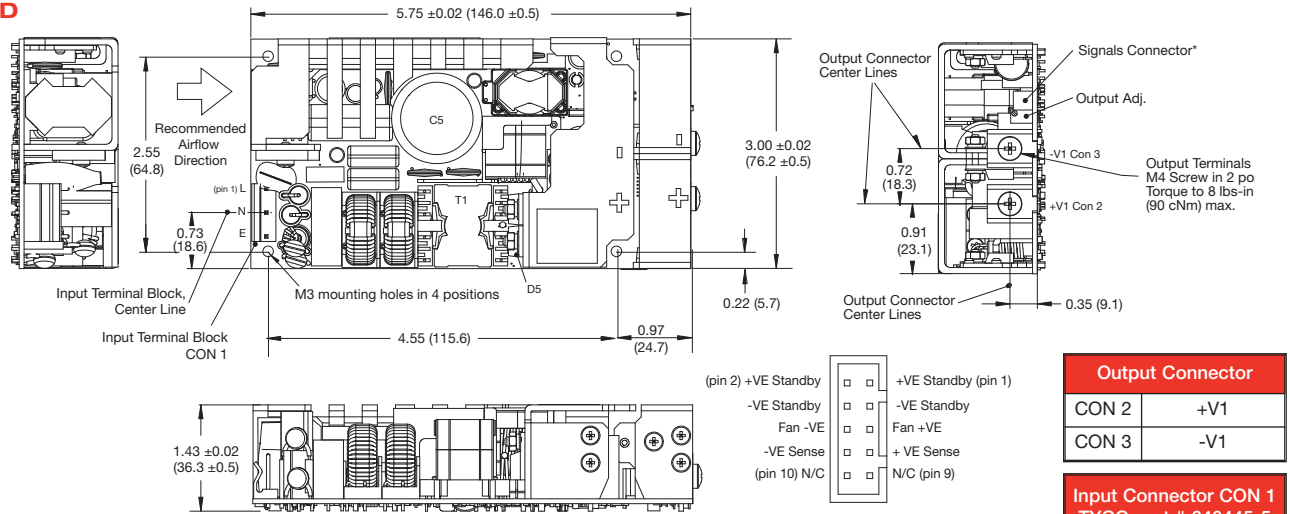

*Signals Connector Top View
Signals Connector 10 way 2 mm pitch part number JST B10B-PHDSS, Mating half part number JST PHDR-10VS, Contact 26-22 AWG part number JST SPHD-001T-P0.5

Output Connector	
CON 2	+V1
CON 3	-V1

Input Connector CON 1 TYCO part # 640445-5	
1	Line
3	Neutral
5	Earth

Pins 2 & 4 removed

Mates with Tyco SL-156 Series Connector

EMH350D (Signal Options)

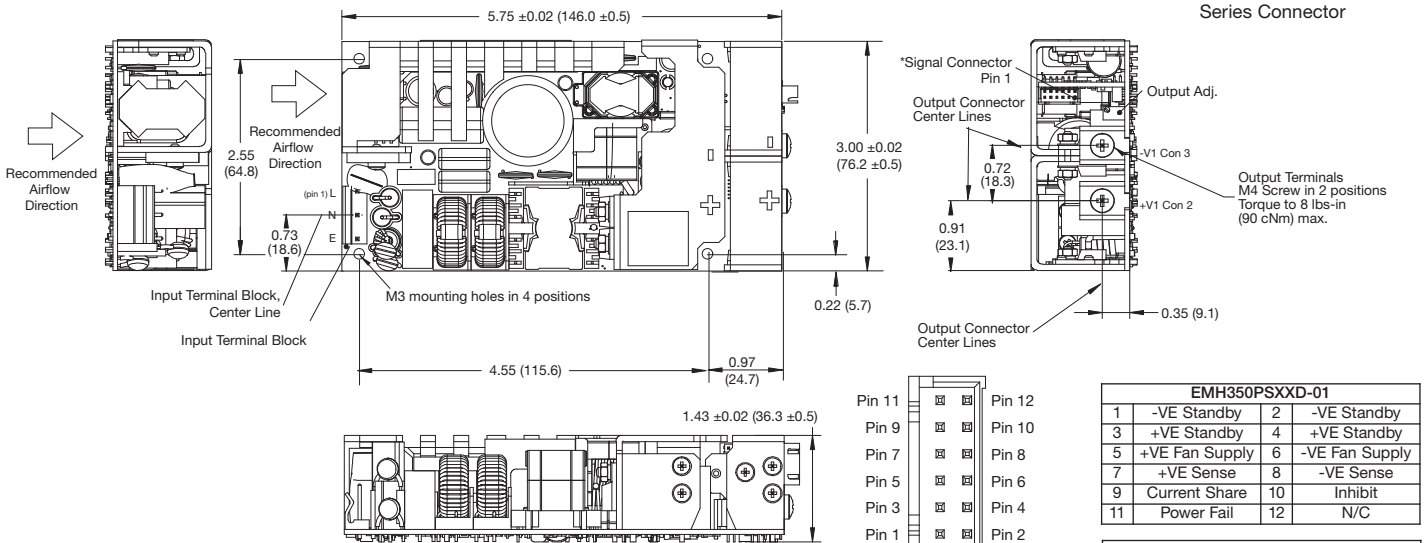

Signals Connector 12 way 2 mm pitch p/n JST S12B-PHDSS Mating Half - p/n JST PHDR-12VS, Contact- 26-22 AWG p/n JST SPHD-001T-P0.5

EMH350PSXXD-01			
1	-VE Standby	2	-VE Standby
3	+VE Standby	4	+VE Standby
5	+VE Fan Supply	6	-VE Fan Supply
7	+VE Sense	8	-VE Sense
9	Current Share	10	Inhibit
11	Power Fail	12	N/C

EMH350PSXXD-50			
1	-VE Standby	2	-VE Standby
3	+VE Standby	4	+VE Standby
5	+VE Fan Supply	6	-VE Fan Supply
7	+VE Sense	8	-VE Sense
9	Fan Tacho Input	10	°C GND
11	°C Data	12	°C Clock

Notes

1. Dimensions shown in inches (mm). Tolerance: ±0.02 (±0.5)

2. Weight: 1.0 lbs (450 g).



Signals Description & Compatibility

Signal & Cover Options										
Model	Functions								Cover Compatibility	
	Remote Sense	Fan Supply	5 V Standby	AC OK/Power Fail	Inhibit V1 & V Fan	Current Share	Variable Speed Fan Control	PMBus	Standard Top Fan (-TF)	Variable Speed Top Fan (-VF)
EMH250PSXX	✓	✓							✓	
EMH350PSXX	✓	✓	✓						✓	
EMH350PSXX-01	✓	✓	✓	✓	✓	✓			✓	
EMH350PSXX-02	✓	✓	✓	✓	✓	✓	✓			✓
EMH350PSXX-50	✓	✓	✓					✓	✓	
EMH350PSXXD	✓	✓	✓							
EMH350PSXXD-01	✓	✓	✓	✓	✓	✓				
EMH350PSXXD-50	✓	✓	✓					✓		

Characteristic	Notes & Conditions
Signals & Control	
Remote Sense	Compensates for 0.5 V total voltage drop
12 V Fan Supply (V3)	12 V/0.6 A supply, present when AC supplied, inhibit turns fan supply off.
5V Standby	5 V/2 A supply, always present when AC supplied
AC OK/Power Fail	AC OK is an open collector transistor, referenced to negative output, providing a minimum of 3 ms warning of loss of output regulation. The transistor is normally on when AC is healthy. See fig. 1.
Inhibit	The inhibit high pin should be pulled below 0.4 V to switch V1 & V Fan (V3) off. Open circuit or 2-8 V maximum to switch the output on. See fig. 2.
Current Share	Connecting pin 9 (-01 & -02 models) of like voltage units (3 maximum) will force the current to share between the outputs. Units share current within 10% of each other at full load. See fig. 3.
Variable Speed Fan Control	When used in conjunction with -VF fan cover, varies the speed of the fan depending on temperature of the unit. See longform datasheet for details.
I2C/PMBus	The I2C PMBus compatible interface can be used for monitoring the unit output voltage, current, internal temperature, external 3 wire TACHO fan and run time. Adjustment of the output voltage and current limit set point and identification of the unit model number and serial number are also possible. See longform datasheet for full details.

AC OK/Power Fail

Figure 1.

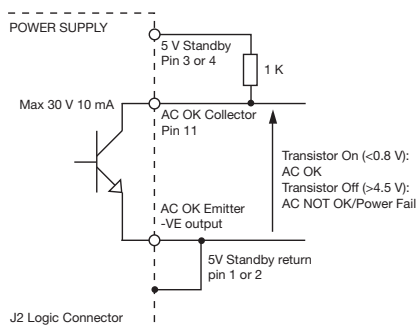

Inhibit

Figure 2.

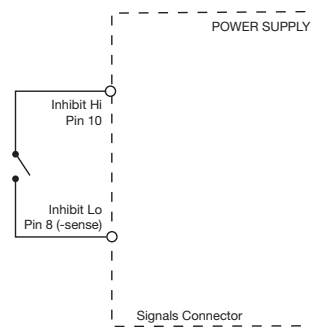

Parallel Load & Current Share

Figure 3.

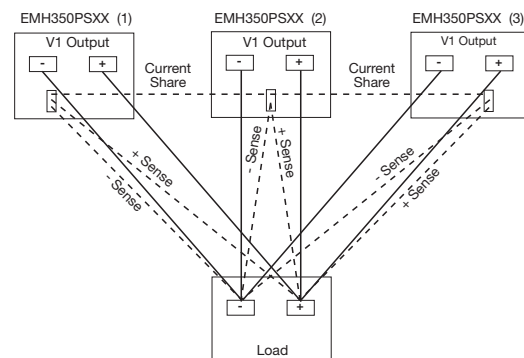

Top Fan - EMH250-TF & EMH350-TF

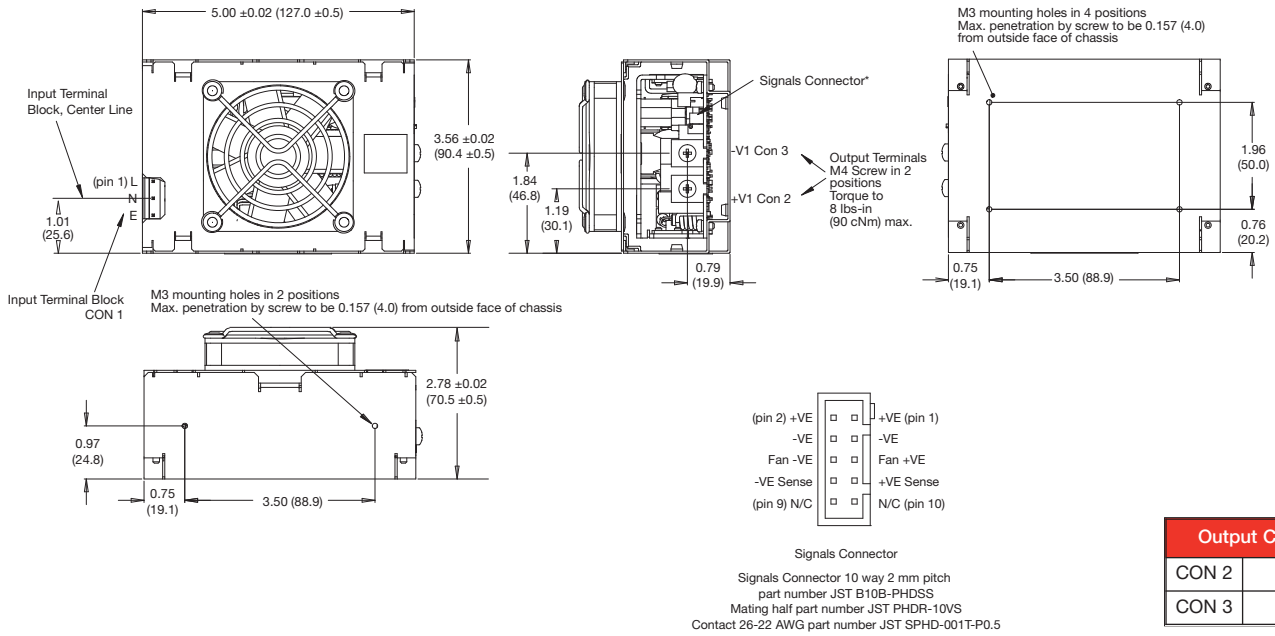

Output Connector	
CON 2	+V1
CON 3	-V1

Input Connector CON 1 TYCO part # 640445-5	
1	Line
3	Neutral
5	Earth

Top Fan with Signals Options - EMH350-01TF, EMH350-50TF & EMH350-02VF

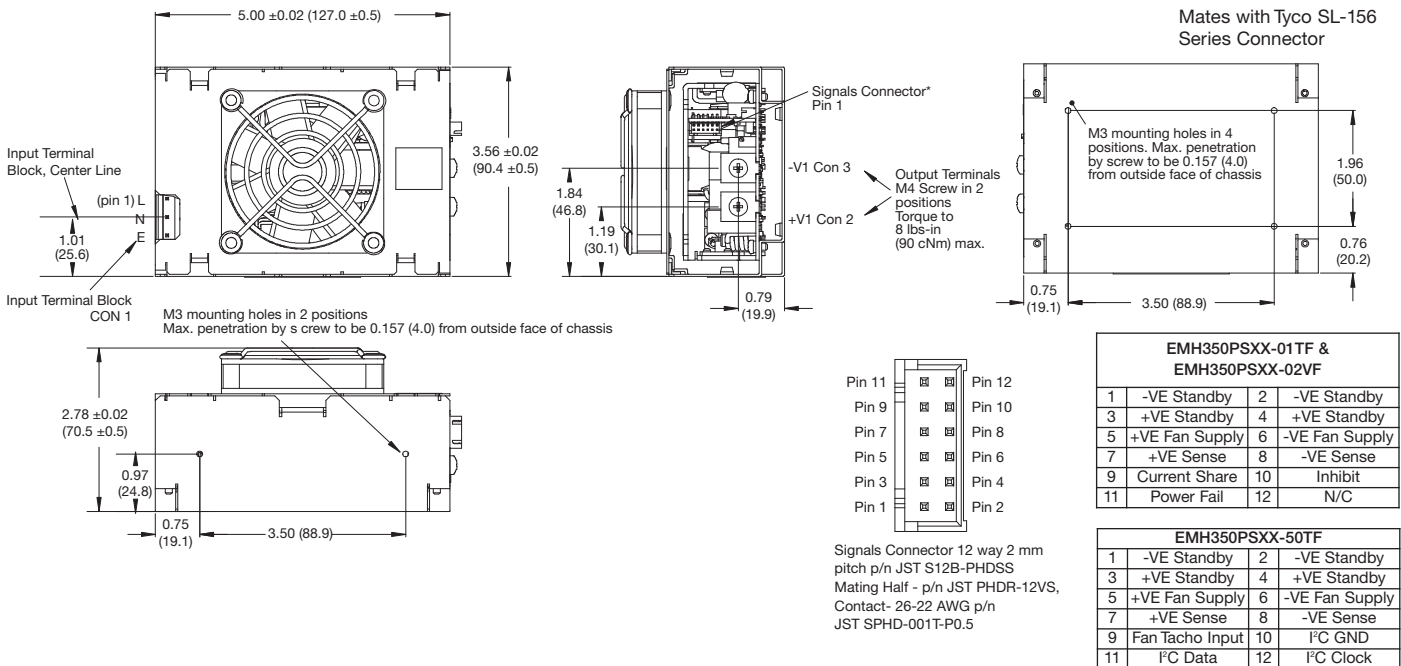

Pins 2 & 4 removed

Mates with Tyco SL-156 Series Connector

Notes

1. Dimensions shown in inches (mm). Tolerance: ±0.02 (±0.5)

2. Weight: 1.67 lbs (760 g).

Models and Ratings - Dual Outputs

Output Voltage V1	Output Current V1	Output Voltage V2	Output Current V2	Standby Supply	Fan Supply V3	Output Power	Model Number ⁽¹⁾
12 V	16.5 A	24 V	8.3 A	5.0 V/2.0 A	12 V/0.6 A	354 W	EMH350PD21-U
12 V	16.5 A	36 V	5.5 A	5.0 V/2.0 A	12 V/0.6 A	354 W	EMH350PD22-U
12 V	16.5 A	48 V	4.2 A	5.0 V/2.0 A	12 V/0.6 A	355 W	EMH350PD23-U
24 V	8.3 A	48 V	4.2 A	5.0 V/2.0 A	12 V/0.6 A	354 W	EMH350PD24-U
60 V	3.3 A	60 V	3.3 A	5.0 V/2.0 A	12 V/0.6 A	354 W	EMH350PD25-U

Notes

- For integral end fan version, replace '-U' in model number with '-EF'
- Output voltages to 120 VDC possible with series output connection contact sales.

Mechanical Details

EMH350PDxx-U

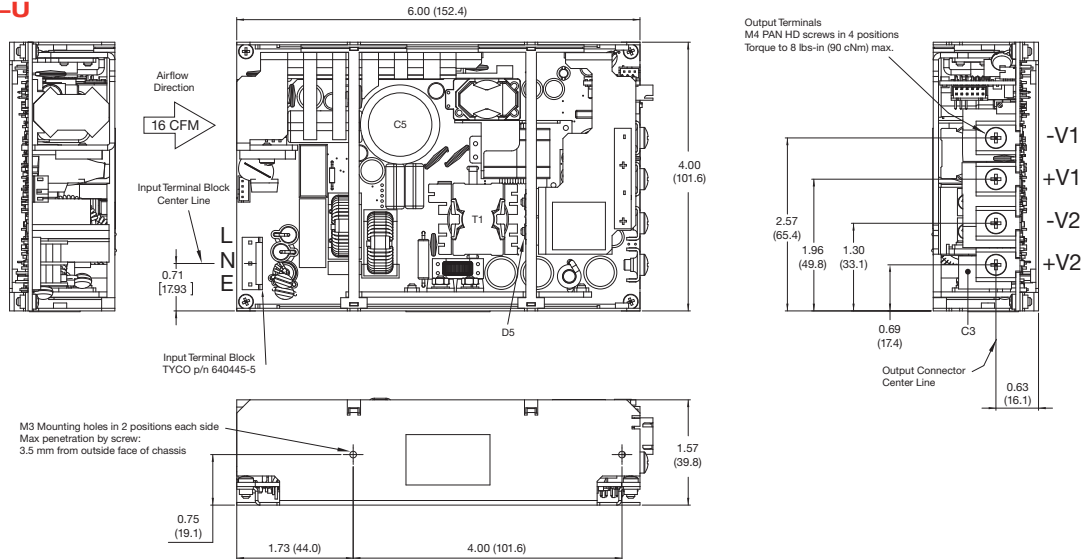

EMH350PDxx-EF

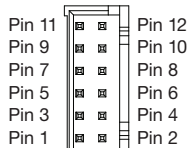
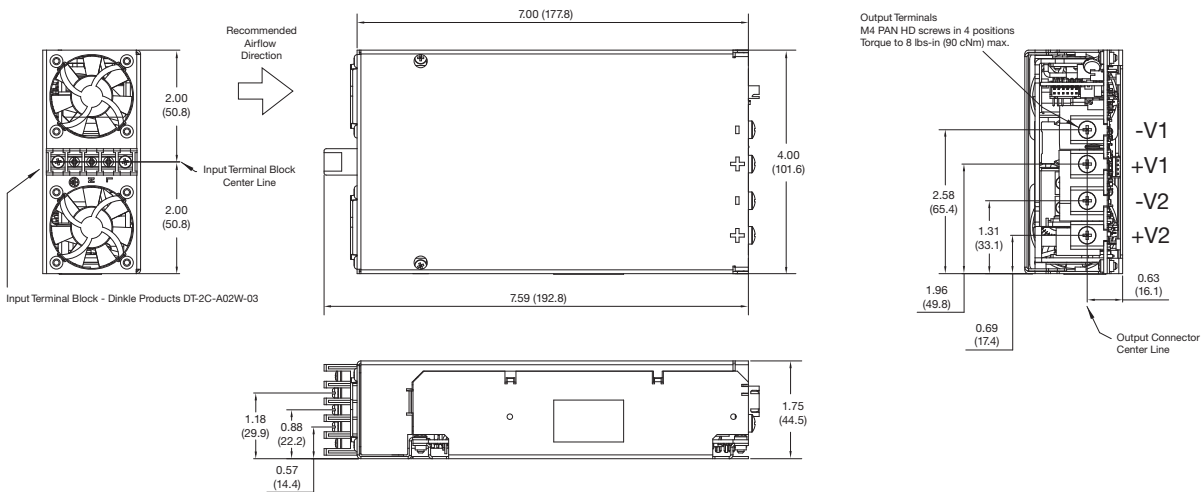

Pin Connections			
Pin	Function	Pin	Function
1	-VE Standby	7	+VE Sense
2	-VE Standby	8	-VE Sense
3	+VE Standby	9	Current Share
4	+VE Standby	10	Inhibit
5	Fan +VE	11	Power Fail
6	Fan -VE	12	Not Connected

Signals Connector - 12 WAY 2mm PITCH p/n JST S12B-PHSS
 Mating HALF - p/n JST PHDR-12VS
 Contact - 26-22 AWG p/n JST SPHD-001T-P0.5

Notes

- Dimensions shown in inches (mm). Tolerance: ±0.02 (±0.5)
- Weight: 0.9 lb (410 g).

Signals Description & Compatibility

Model	Functions							
	Remote Sense	Fan Supply	5 V Standby	AC OK/ Power Fail	Inhibit V1 & V Fan	Current Share	Variable Speed Fan Control	PMBus
EMH350PDxx-U	✓	✓	✓	✓	✓	✓		Contact Sales
EMH350PDxx-EF	✓	✓	✓	✓	✓	✓	✓	

Characteristic	Notes & Conditions
Signals & Control	
Remote Sense	Compensates for 0.5 V total voltage drop
12 V Fan Supply (V3)	12 V/0.6 A supply, present when AC supplied, inhibit turns fan supply off.
5V Standby	5V/2 A supply, always present when AC supplied
AC OK/Power Fail	AC OK is an open collector transistor, referenced to negative sense, providing a minimum of 3 ms warning of loss of output regulation. The transistor is normally off when AC is healthy. See fig. 4.
Inhibit	The inhibit high pin should be pulled below 0.4 V to switch V1, V2 & V Fan (V3) off. Open circuit or 2-8 V maximum to switch the output on. See fig. 5.
Current Share	Connecting pin 9 (-01 & -02 models) of like voltage units (3 maximum) will force the current to share between the outputs. Units share current within 10% of each other at full load. See fig. 6.
Variable Speed Fan Control	Only available for -EF models. Varies the speed of the integral fans depending input voltage, output power & ambient temperature within the unit.

AC OK/Power Fail

Figure 4.

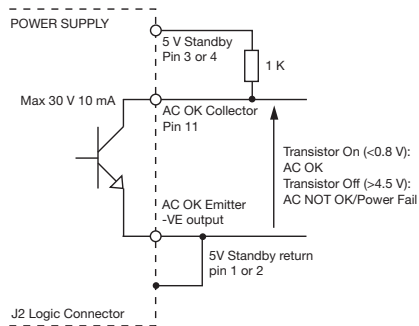

Inhibit

Figure 5.

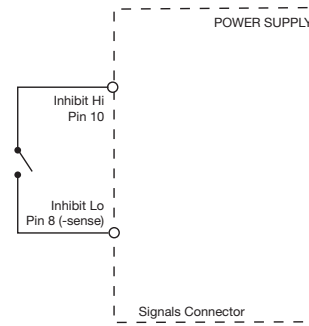

Parallel Load & Current Share

Figure 6.

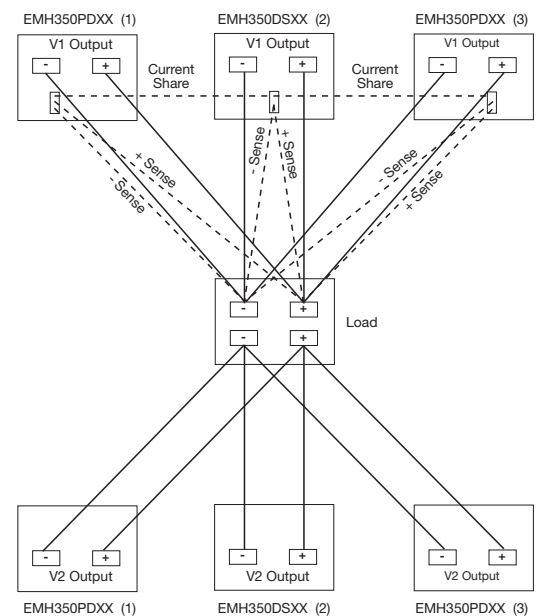

EMH350PD21

V2 Cross Regulation

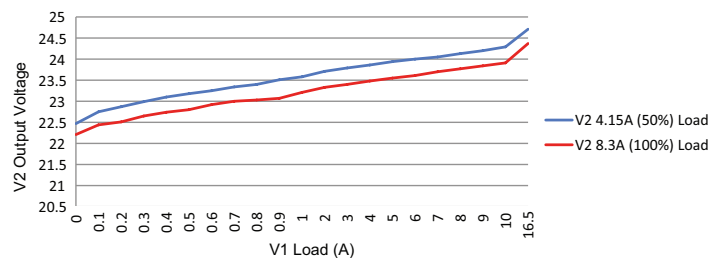

V2 Load Regulation

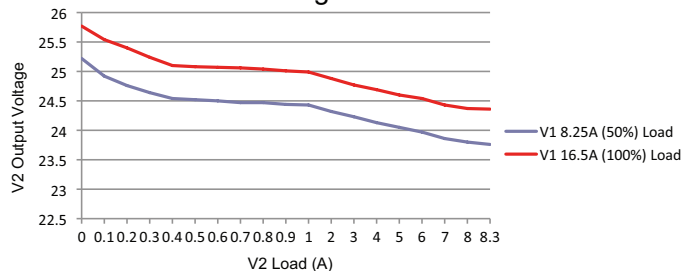

EMH350PD22

V2 Cross Regulation

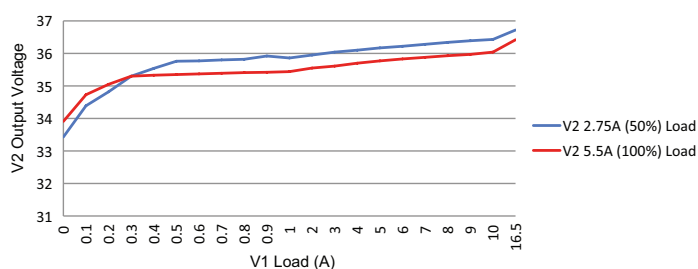

V2 Load Regulation

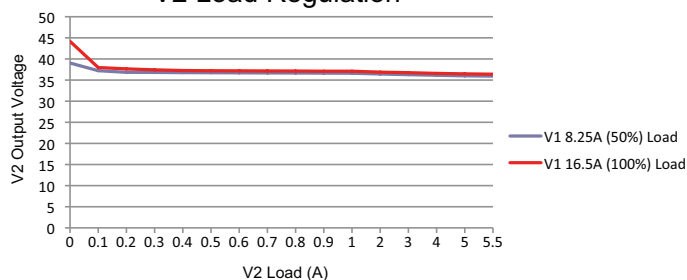

EMH350PD23

V2 Cross Regulation

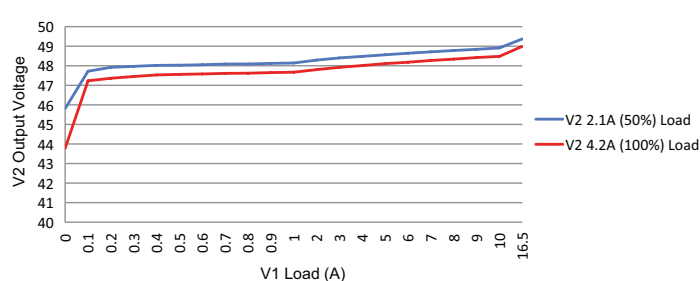

V2 Load Regulation

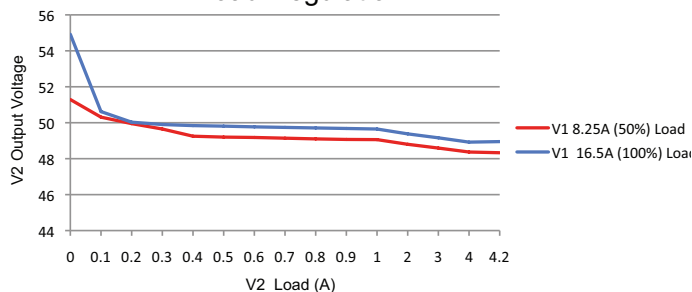

EMH350PD24

V2 Cross Regulation

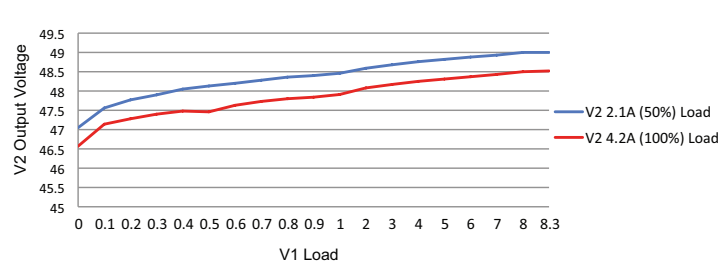

V2 Load Regulation

