



### Main

Range of product	Preventa Safety automation
Product or component type	Preventa safety module
Safety module name	XPSBCE
Safety module application	For electrical monitoring of two-hand control stations
Function of module	Monitoring two-hand control station
Safety level	Can reach PL e/category 4 conforming to EN/ISO 13849-1 Can reach SILCL 3 conforming to EN/IEC 62061
Safety reliability data	DC > 99 % conforming to EN/ISO 13849-1 MTTFd = 37 years conforming to EN/ISO 13849-1 PFHd = 3E-8 1/h conforming to EN/IEC 62061
Connections - terminals	Captive screw clamp terminals, removable terminal block, clamping capacity: 1 x 0.2...1 x 2.5 mm <sup>2</sup> solid cable without cable end Captive screw clamp terminals, removable terminal block, clamping capacity: 1 x 0.2...1 x 2.5 mm <sup>2</sup> flexible cable without cable end Captive screw clamp terminals, removable terminal block, clamping capacity: 1 x 0.25...1 x 2.5 mm <sup>2</sup> flexible cable with cable end, without bezel Captive screw clamp terminals, removable terminal block, clamping capacity: 1 x 0.25...1 x 1.5 mm <sup>2</sup> flexible cable with cable end, with bezel Captive screw clamp terminals, removable terminal block, clamping capacity: 2 x 0.2...2 x 1 mm <sup>2</sup> solid cable without cable end Captive screw clamp terminals, removable terminal block, clamping capacity: 2 x 0.2...2 x 1 mm <sup>2</sup> flexible cable without cable end Captive screw clamp terminals, removable terminal block, clamping capacity: 2 x 0.25...2 x 1 mm <sup>2</sup> flexible cable with cable end, without bezel Captive screw clamp terminals, removable terminal block, clamping capacity: 2 x 0.5...2 x 1.5 mm <sup>2</sup> flexible cable with cable end, with double bezel
Output type	Relay 2 NO, volt-free
Number of additional circuits	1 NC
[Us] rated supply voltage	24 V AC/DC (- 15...10 %)

### Complementary

Synchronisation time between inputs	0.5 s
Supply frequency	50/60 Hz
Power consumption	<= 4 VA

Input protection type	Internal, electronic
Number of inputs	1 NC + NO
Input compatibility	Two-hand control conforming to EN 574/ISO 13851-III C
Control circuit voltage	24 V DC
Breaking capacity	B300 : holding 360 VA AC-15 for relay output B300 : inrush 3600 VA AC-15 for relay output
Breaking capacity	1.5 A / 24 V - L/R = 50 ms, DC-13 for relay output
[I <sub>th</sub> ] conventional free air thermal current	<= 6 A
Associated fuse rating	6 A gG for relay output conforming to EN/IEC 60947-5-1, DIN VDE 0660 part 200
Minimum output current	10 mA for relay output
Minimum output voltage	17 V for relay output
Response time on input open	<= 50 ms
[U <sub>i</sub> ] rated insulation voltage	300 V, degree of pollution 2 conforming to IEC 60947-5-1 300 V, degree of pollution 2 conforming to DIN VDE 0110 part 1
[U <sub>imp</sub> ] rated impulse withstand voltage	4 kV overvoltage category III, conforming to IEC 60947-5-1 4 kV overvoltage category III, conforming to DIN VDE 0110 part 1
Local signalling	3 LEDs
Mounting support	35 mm symmetrical DIN rail
Product weight	0.272 kg

## Environment

Standards	EN/IEC 60204-1 EN 574 type III C/ISO 13851 EN/IEC 60947-5-1
Product certifications	BG UL CSA
IP degree of protection	IP20(Terminals) conforming to EN/IEC 60529 IP40(Enclosure) conforming to EN/IEC 60529
Ambient air temperature for operation	-25...55 °C
Ambient air temperature for storage	-25...75 °C

## Contractual warranty

Warranty period	18 months
-----------------	-----------

Dimensions

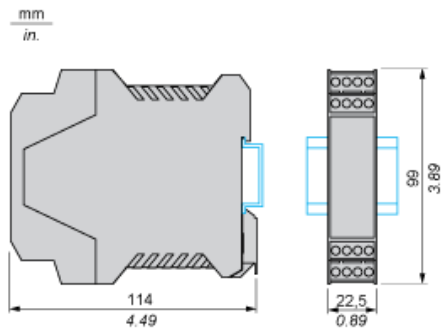

## Wiring Diagrams

### Refer to the Instruction Sheet

To download the instruction sheet, follow below procedure:

**XPSAC5121**  
module XPSAC - Emergency stop - 24 V AC DC  
[Download XPSAC5121 product datasheet](#)

Download & Documents 1 to 3 of 3 (Total: -1)

**Instruction sheet**

XPSAC... Safety module for emergency stop and switch monitoring	English 2012-07-04	pdf (29)
---	--------------------	----------

**Image of product**

Emergency stop and switch monitoring	2010-11-10	(Select :)
--------------------------------------	------------	------------

**Certificate**

Russian certificate	English 2010-07-07	pdf (60)
---------------------	--------------------	----------

- 1 Click on Download & Documents.
- 2 Click on Instruction sheet.