

ZBRN2

access point - 2 RJ45-24..240V AC/DC-4
displays-5 LEDs-Modbus-wireless radio



Main

Range of product	Harmony
Product or component type	Wireless access point
Device short name	ZBRN2
Product specific application	Interface to PLC
Function of module	Monostable
Communication port protocol	Zigbee green power at 2.4 GHz conforming to IEEE 802.15.4
Antenna type	Integrated
Transmission frequency	2405 MHz for receiver

Complementary

[Us] rated supply voltage	24...240 V AC/DC at 50/60 Hz (- 10...10 %)
Immunity to microbreaks	10 ms
Maximum sensing distance	100 m (in free field) 25 m (transmitter in a plastic box type XAL D and receiver in a metal enclosure) 40 m (transmitter in box type XAL D, receiver in metal enclosure and use relay-antenna) 60 m (transmitter in a plastic box type XAL D and use relay-antenna)
Response time	< 30 ms after transmitter clicks
Channels utilisation	<= 60
Power consumption in W	<= 4 W AC/DC
Breaking capacity	15 W
Breaking capacity	750 VA
Control circuit frequency	50...60 Hz +/- 10 %
Short circuit protection	16 A by GB2 circuit breaker
Operating position	Any position without derating
Tightening torque	0.35...0.4 N.m conforming to EN/IEC 60947-1
Housing material	Self-extinguishing plastic
Status LED	1 LED (green) : power ON 1 LED (yellow) : communication network 5 LEDs (red) : function mode

	1 LED (green and yellow) : reception signal
Mounting support	Mounting plate 35 mm symmetrical DIN rail conforming to EN/IEC 60715
Rated short-duration power frequency withstand voltage	1.5 kV at 50 Hz conforming to EN/IEC 60947-5-1
[Uimp] rated impulse withstand voltage	4 kV
Surge withstand	1 kV (differential mode) conforming to IEC 61000-4-5 2 kV (common mode) conforming to IEC 61000-4-5
Width	122 mm
Height	90 mm
Depth	60 mm
Product weight	0.27 kg
Antenna gain	0 dBi
Marking	CE
Integrated connection type	1 isolated serial link (2 x RJ45 in parallel in Modbus Serial line slave) ,Modbus slave RTU asynchronous in baseband RS485 half duplex 1.2...115.2 kbauds 2 twisted shielded pairs
Data storage equipment	SD card
Topology	Devices linked by daisy-chaining or tap junctions
Data format	7 or 8 bits, 1 or 2 stop bits
Parity	Even Odd No

Environment

Radio agreement	SRRC ICASA ANATEL type III conforming to ETSI EN 301 489-3 FCC category 2 conforming to ETSI EN 300 440-1 RSS category 1 conforming to ETSI EN 300 440-1
Product certifications	UL CSA CCC CE GOST C-Tick
Directives	2006/95/EC - low voltage directive 1999/5/EC - R&TTE directive 2004/108/EC - electromagnetic compatibility
Standards	CSA C22.2 No 14 ETSI EN 300 328 ETSI EN 300 440-2 EN 62311 UL 508 EN/IEC 60950-1 EN/IEC 61131-2
Ambient air temperature for storage	-40...70 °C
Relative humidity	90 % (-25...55 °C) without condensation conforming to ETSI EN 300 440-1
Operating altitude	0...2000 m
Storage altitude	0...3000 m
Vibration resistance	+/- 3.5 mm (f= 5...14 Hz) conforming to IEC 60068-2-6 1 gn (f= 5...150 Hz) on panel mounting conforming to IEC 60068-2-6 2 gn (f= 8...150 Hz) on DIN rail conforming to IEC 60068-2-6
Shock resistance	10 gn (6000 shocks during 16 ms) conforming to IEC 60068-2-27
IP degree of protection	IP20 (casing) conforming to IEC 60529 IP20 (terminals)
Pollution degree	2 conforming to IEC 60664-1
Electromagnetic compatibility	1.2/50 µs shock waves immunity test :1 kV (differential mode) conforming to IEC 61000-4-5 1.2/50 µs shock waves immunity test :2 kV (common mode) conforming to IEC 61000-4-5 Immunity to microbreaks and voltage drops :10 ms conforming to IEC 61000-4-11
Dielectric strength	3000 V AC between input and output 4250 V DC between input and output 1500 V AC between input and ground

Offer Sustainability

Sustainable offer status	Not Green Premium product
RoHS (date code: YYWW)	Compliant - since 1402 - Schneider Electric declaration of conformity Schneider Electric declaration of conformity
REACH	Reference not containing SVHC above the threshold Reference not containing SVHC above the threshold

Access Point

Dimensions

Access Point on a Mounting Panel

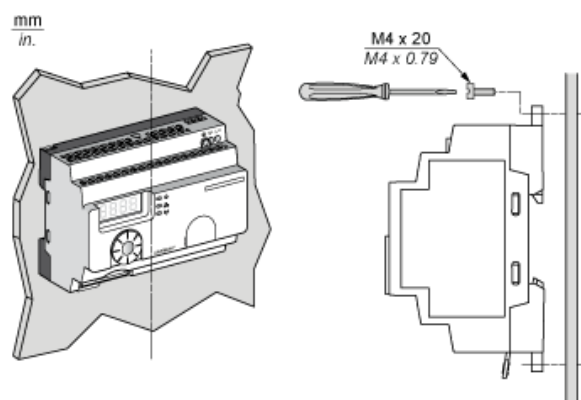

The Access Point is installed according to its vertical axis

Access Point on DIN rail Mounting

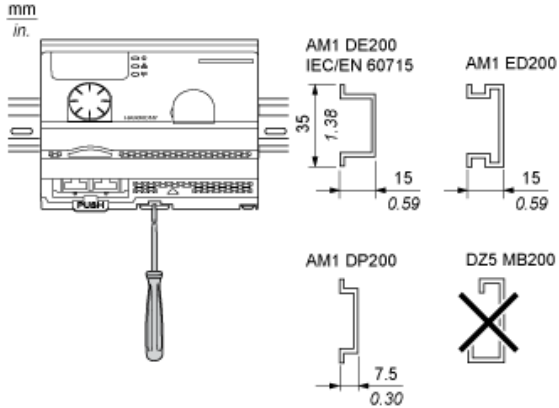

Clearances

Maximum Distance between Transmitter and the Access Point in Free Field Unobstructed

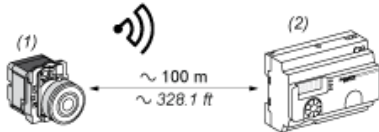

- (1) Transmitter
- (2) Access Point

Maximum Distance between Transmitter and the Access Point in a Metal enclosure without a Relay Antenna

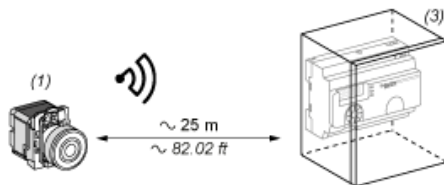

- (1) Transmitter
- (3) Access Point in a Metal enclosure

Maximum Distance between Transmitter and the Access Point in a Metal Enclosure with a Relay Antenna

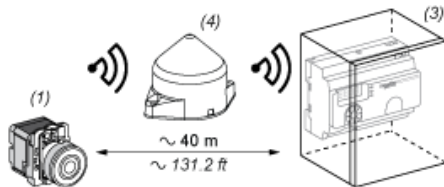

- (1) Transmitter
- (3) Access Point in a Metal enclosure
- (4) Relay Antenna

Maximum Distance between Transmitter and the Access Point in a Metal Enclosure with a Passive Antenna

- (1) Transmitter
- (2) External Antenna
- (3) Access Point in a Metal enclosure

The range is reduced if the transmitter is placed in a metal enclosure (reduction factor : approx 10%)

Glass window	10...20 %
Plaster wall	30...45 %
Brick wall	60 %
Concrete wall	70...80 %
Metal structure	50...100 %

Access Point Clearances

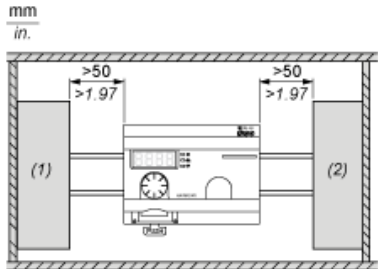

- (1) Power Supply
- (2) Programmable Logic Controller

Access Point Wiring Diagram

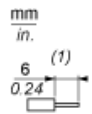
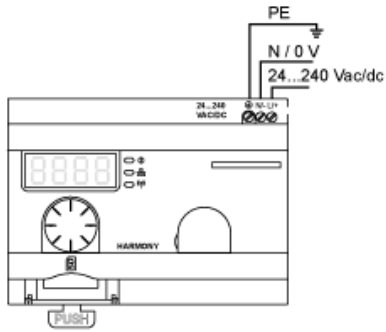

(1) wire sizes for Power Supply terminals (L/+,N/-)