

PCB TERMINAL BLOCKS

3.5mm Pitch Ultra Low Profile Rising Clamp Terminal

- 2-12 pole interlocking
- 4-12 pole pre-assembled
- Ultra low profile
- Moulded in green UL94-V0 flame retardant PA
- Professional rising clamp terminals
- 0.2-1.5mm² (30-16AWG) solid cable
- 0.2-1.0mm² (30-16AWG) stranded cable
- Captive screws
- Guided pin alignment
- Double interlock mechanism for increased strength
-  approved

CTB0305

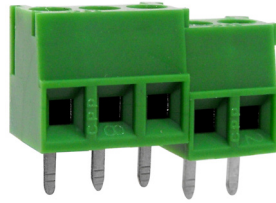

TYPE NO.	POLES	LENGTH
CTB0305/2	2	7mm
CTB0305/3	3	10.5mm
CTB0305/4	4	14mm
CTB0305/5	5	17.5mm
CTB0305/6	6	21mm
CTB0305/7	7	24.5mm
CTB0305/8	8	28mm
CTB0305/9	9	31.5mm
CTB0305/10	10	35mm
CTB0305/11	11	38.5mm
CTB0305/12	12	42mm

SPECIFICATION

Rating	10A/160V UL=10A/300V, VDE&IMQ=10A/130V
Dielectric strength	≥1.25kV
Impulse withstand voltage	2.5kV
Working temperature	110°C
Moulding	UL94-V0 flame retardant PA66
Pin/terminal	Tinned, nickel plated brass
Rising Clamp	Tinned, nickel plated brass
Screw/torque	M2 steel zinc plated, 0.3Nm
Recommended PCB hole size	ø1.1mm

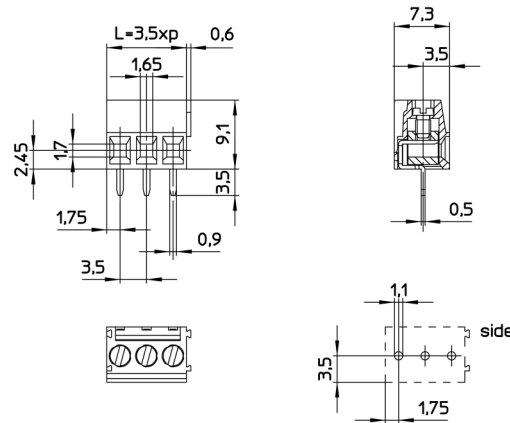

3.5mm Pitch Ultra Low Profile 90° Rising Clamp Terminal

- 2-12 pole interlocking
- 4-12 pole pre-assembled
- Ultra low profile
- Moulded in green UL94-V0 flame retardant PA
- Professional rising clamp terminals
- 0.2-1.5mm² (30-16AWG) solid cable
- 0.2-1.0mm² (30-16AWG) stranded cable
- Captive screws
- Guided pin alignment
- Double interlock mechanism for increased strength
-  approved

CTB0355



TYPE NO.	POLES	LENGTH
CTB0355/2	2	7mm
CTB0355/3	3	10.5mm
CTB0355/4	4	14mm
CTB0355/5	5	17.5mm
CTB0355/6	6	21mm
CTB0355/7	7	24.5mm
CTB0355/8	8	28mm
CTB0355/9	9	31.5mm
CTB0355/10	10	35mm
CTB0355/11	11	38.5mm
CTB0355/12	12	42mm

SPECIFICATION

Rating	10A/160V UL=10A/300V, VDE&IMQ=10A/130V
Dielectric strength	1.25kV
Impulse withstand voltage	2.5kV
Working temperature	110°C
Moulding	UL94-V0 flame retardant PA66
Pin/terminal	Tinned, nickel plated brass
Rising clamp	Tinned, nickel plated brass
Screw/torque	M2 steel zinc plated, 0.3Nm
Recommended PCB hole size	ø1.1mm

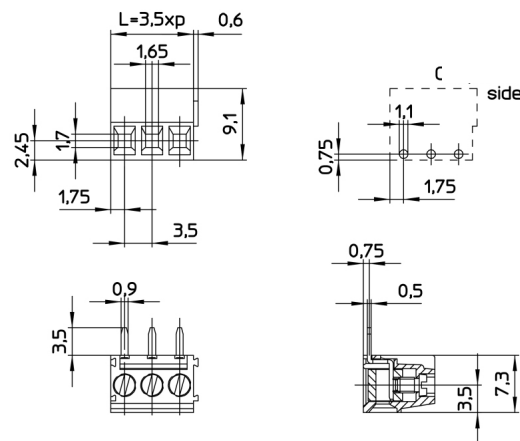

PCB
TERMINAL
BLOCKS

INTER-
CONNECTION

FUSES &
FUSE-
HOLDERS

LEDs &
INDICATORS

MINIATURE
SWITCHES

LIMIT &
SAFETY
SWITCHES

CONTROL
PRODUCTS

INTERFACE
MODULES &
SUPPORTS

RELAY
BASES

DIN RAIL
ENCLOSURES

BATTERIES

SOLAR
PANELS

TRANS-
FORMERS