

# GALAXY

- General purpose economy floodlight
- Vandal resistant polycarbonate body
- IP65 dust tight and water jet proof
- Hinged, impact resistant visor
- Integral photocell option for 'dusk to dawn' operation
- Easy to install

Manufactured from tough, vandal resistant polycarbonate, Galaxy remains a popular choice for general purpose floodlighting. Compact styling and a dispersive reflector allow Galaxy to be used in a wide variety of applications, such as hotel car parks, pub signs and building façades. As standard, all luminaires are sealed to IP65 - dust tight and water jet proof - delivering long and durable through-life service. A choice of SON lamp options, including a value for money integral ignitor version, provides efficient illumination. Alternatively, where a white light appearance is preferred, metal halide and mercury lamps offer further choice. Integral photocell options enhance the Galaxy range, underlining its versatility.



#### WHERE TO USE GALAXY

- General floodlighting
- Building façades
- Car parks
- Loading bays
- Security lighting
- Garden lighting
- Building perimeters
- Signs



**LAMP OPTIONS**

- 70W SON-T - E27 cap
- 70W SONE/1 (internal ignitor) - E27 cap
- 100W HQI-E - E27 cap
- 80W, 125W MBFU Deluxe - E27 cap

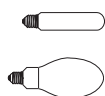

**MATERIALS**

- Body - UV stabilised polycarbonate, self coloured black
- Visor - UV stabilised clear polycarbonate
- Reflector - high purity, high reflectance, anodised aluminium
- Stirrup - steel, powder coated in black finish

**INSTALLATION NOTES**

- Suitable for column, wall and floor mounting
- Stirrup bolts directly to surface
- Cable gland supplied for 8-13mm circular flex
- 3 way, 1x2.5mm<sup>2</sup> terminal block
- Gear mounted on removable geartray, secured by screws
- Visor retained by 2 captive screws. Hinges for easy lamp replacement
- Supplied complete with lamp
- Safety distance - 0.5m

**DIMENSIONS**

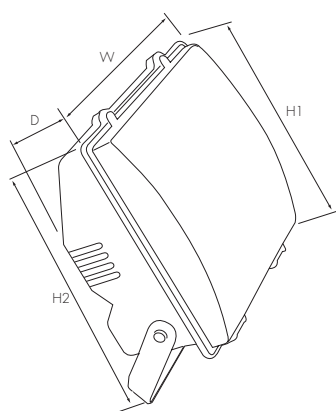

H1 (mm)	H2 (mm)	W (mm)	D (mm)
322	375	300	190

**OPTIONS**

- Integral photocell versions available
- Full range of columns and brackets available. See page 381
- Thermal cut out on SON/HQI lamp ballast as standard

**SPECIFICATION**

To specify state: Polycarbonate, general purpose floodlight, dust tight and water jet proof to IP65, with high efficiency, dispersive, anodised aluminium reflector, quick release hinging polycarbonate visor, removable geartray and optional integral photocell, as Crompton Galaxy range, part no. \_\_\_\_\_

**PHOTOMETRIC DATA**

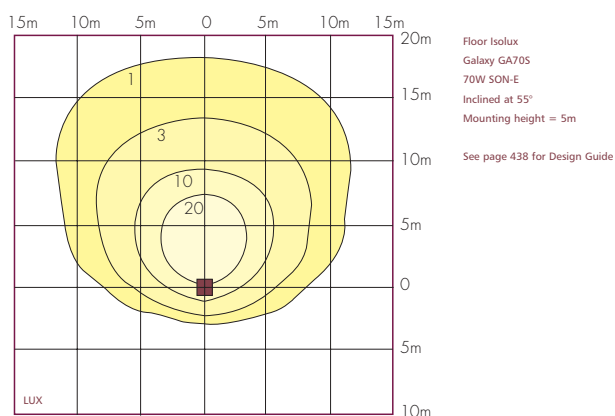

**CATALOGUE NUMBERS**

Lamp Rating	Lamp Type	Without Photocell	With Photocell	Weight (kg)
1 x 70W	SONE/1 (internal ignitor)	GA70S	GA70SPEC	3.5
1 x 70W	SON-T	GA70T	GA70TPEC	3.6
1 x 100W	HQI-E	GA100MBI	-	4.4
1 x 80W	MBFU Deluxe	GA80M	GA80MPEC	3.4
1 x 125W	MBFU Deluxe	GA125M	GA125MPEC	3.6