

12W 12V SMPS Demo Board with ICE3AR4780JG

AN-DEMO-3AR4780JG

About this document

Scope and purpose

This document is an engineering report that describes universal input 12 W 12 V off-line flyback converter power supply using Infineon CoolSET™ F3R80 family, ICE3AR4780JG (DSO16/12). The converter is operated in Discontinuous Conduction Mode, 100 kHz fixed frequency, low standby power, brownout and various mode of protections for a high reliable system. This demo board is designed to evaluate the performance of ICE3AR4780JG in ease of use.

Intended audience

This document is intended for power supply design/application engineer, students, etc.) who wish to design low cost and high reliable systems of off-line Switched Mode Power Supply (SMPS) for enclosed adapter, blu-ray/DVD player, set-top box, game console, smart meter, auxiliary power supply of white goods, PC, server, etc.

Table of Contents

	About this document.....	1
1	Abstract.....	3
2	Demonstrator board	4
3	Specifications of Demonstrator Board.....	5
4	Circuit description	6
4.1	Line input	6
4.2	Brownout (Line under voltage protection).....	6
4.3	Start up.....	6
4.4	Operation mode	6
4.5	Soft start.....	6
4.6	RCD clamper circuit.....	6
4.7	Peak current control of primary current.....	6
4.8	Output stage	7
4.9	Feedback and regulation.....	7
4.10	Active burst mode	7
4.11	Jittering and soft gate drive	7
4.12	Protection function	7
5	Circuit diagram.....	9
6	PCB layout	11
6.1	Top side	11
7	Bill of material.....	12
8	Transformer construction.....	13
9	Test results	14
9.1	Efficiency, regulation and output ripple	14
9.2	Standby power.....	16
9.3	Line regulation.....	16



Abstract

9.4	Load regulation	17
9.5	Maximum input power.....	17
9.6	ESD immunity (EN61000-4-2).....	17
9.7	Surge immunity (EN61000-4-5).....	17
9.8	Conducted emissions (EN55022 class B)	18
9.9	Thermal measurement	20
10	Waveforms and scope plots	21
10.1	Startup at low/high AC line input voltage with maximum load	21
10.2	Soft start.....	21
10.3	Frequency jittering.....	22
10.4	Drain and current sense voltage at maximum load.....	22
10.5	Load transient response (Dynamic load from 10% to 100%)	23
10.6	Output ripple voltage at maximum load	23
10.7	Output ripple voltage at burst mode 1 W load	24
10.8	Active burst mode	24
10.9	VCC over voltage protection (Odd skip auto restart mode).....	25
10.10	Over load protection (Odd skip auto restart mode)	25
10.11	VCC under voltage/Short optocoupler protection (Auto restart mode).....	26
10.12	External protection enable (Non switch auto restart mode).....	26
10.13	Brownout Mode (Non switch auto restart mode)	27
11	References	28
	Revision History	28

Abstract

1 Abstract

This document is an engineering report of an universal input 12 W 12 V off-line flyback converter power supply utilizing F3R80 CoolSET™ ICE3AR4780JG. The application demo board is operated in Discontinuous Conduction Mode (DCM) and is running at 100 kHz fixed switching frequency. It has a single output voltage with secondary side control regulation. It is especially suitable for small power supply such as enclosed adapter, blu-ray/DVD player, set-top box, game console, smart meter or open frame auxiliary power supply of white goods, PC, server, etc. Besides having the basic features of the F3R CoolSET™ such as active burst mode, propagation delay compensation, soft gate drive, auto restart protection for major faults (Vcc over voltage, Vcc under voltage, over temperature, over-load, open loop and short opto-coupler), it also has the BiCMOS technology design, selectable entry and exit burst mode level, adjustable brownout feature, built-in soft start time, built-in and extendable blanking time, frequency jitter feature and external auto-restart enable, etc. The particular features need to be stressed are the best-in-class low standby power and the good EMI performance.

2 Demonstrator board

This document contains the list of features, the power supply specification, schematic, bill of material and the transformer construction documentation. Typical operating characteristics such as performance curve and scope waveforms are showed at the rear of the report.



Figure 1 DEMO-3AR4780JG (Top View)

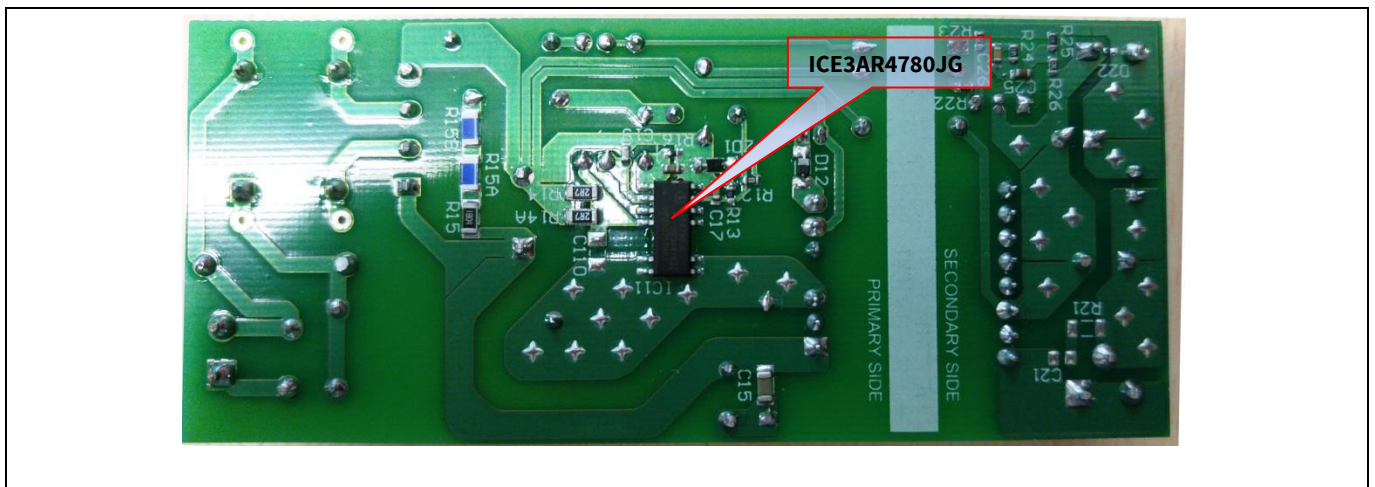

Figure 2 DEMO-3AR4780JG (Bottom view)

Specifications of Demonstrator Board

3 Specifications of Demonstrator Board

Table 1 Specifications of DEMO-3AR4780JG

Input voltage and frequency	85 V _{AC} (60 Hz) ~ 282 V _{AC} (50Hz)
Output voltage, current and power	12 V, 1 A, 12 W
Dynamic load response (10% to 100% load, slew rate at 1 A/μs, 100 Hz)	±3% of nominal output voltage (V _{ripple_p-p} < 150 mV)
Output ripple voltage (full load, 85 V _{AC} ~ 282 V _{AC})	±1% of nominal output voltage (V _{ripple_p-p} < 50 mV)
Active mode four point average efficiency (25%, 50%, 75%, 100% load) (EU CoC Version 5, Tier 2 and EPS of DOE USA)	> 84% at 115 V _{AC} and 230 V _{AC}
10% load efficiency (EU CoC Version 5, Tier 1)	> 75% at 115 V _{AC} and 230 V _{AC}
No load power consumption (EU CoC Version 5, Tier 1)	< 75 mW at 115 V _{AC} and 230 V _{AC}
Conducted emissions (EN55022 class B)	Pass with 9 dB margin
ESD immunity (EN61000-4-2)	Special Level (±16 kV for both contact and air discharge)
Surge immunity (EN61000-4-5)	Installation class 4 (±2 kV for line to line and ±4 kV for line to earth)
Form factor case size (L x W x H)	(103 x 44 x 24) mm ³

Circuit description

4 Circuit description

4.1 Line input

The AC line input side comprises the input fuse F1 as over-current protection. The choke L11, X-capacitors C11, and Y-capacitor C12 act as EMI suppressors. Optional spark gap device SA1, SA2 and varistor VAR can absorb high voltage stress during lightning surge test. After the bridge rectifier BR1 and the input bulk capacitor C13, a voltage of 90 to 400 V_{dc} is present which depends on input line voltage.

4.2 Brownout (Line under voltage protection)

To avoid the system damaged due to line under voltage, brownout feature is implemented by sensing the voltage level at BBA pin through the resistors divider from the bulk capacitor. Once the voltage level at BBA pin falls below 0.9V, the controller stops switching and enters into brownout mode. It is until the input level goes back to input voltage range and the V_{cc} hits 17V, the brownout mode is released.

4.3 Start up

Since there is a built-in startup cell in the ICE3AR4780JG, no external start up resistor is required. The startup cell is connecting the drain pin of the IC. Once the voltage is built up at the drain pin of the ICE3AR4780JG, the startup cell will charge up the V_{CC} capacitor C16 and C17. When the V_{VCC} exceeds the on-threshold (V_{VCC} = 17 V), the IC starts up. Then the V_{CC} voltage is bootstrapped by the auxiliary winding to sustain the operation.

4.4 Operation mode

During operation, the V_{CC} pin is supplied via a separate transformer winding with associated rectification D12 and buffering C16 and C17. In order not to exceed the maximum voltage at V_{CC} pin due to poor coupling of transformer winding, an external zener diode ZD11 and resistor R13 can be added.

4.5 Soft start

The soft start is a built-in function and is set at 10 ms.

4.6 RCD clamper circuit

While turns off the CoolMOS™, the clamper circuit R11, C15 and D11 absorbs the current caused by transformer leakage inductance once the voltage exceeds designed clamp voltage. Finally drain to source voltage is lower than the maximum break down voltage of CoolMOS™.

4.7 Peak current control of primary current

The CoolMOS™ drain source current is sensed via external shunt resistors R14 and R14A which determine the tolerance of the current limit control. Since ICE3AR4780JG is a current mode controller, it would have a cycle-by-cycle primary current and feedback voltage control which can make sure the maximum power of the converter is controlled in every switching cycle. Besides, the patented propagation delay compensation is implemented to ensure the maximum input power can be controlled in an even tighter manner. The demo board shows approximately ±3.67% of average maximum input power (Figure 12).

Circuit description

4.8 Output stage

On the secondary side the power is coupled out by a schottky diode D21. The capacitor C22 provides energy buffering following with the LC filter L21 and C24 to reduce the output voltage ripple considerably. Storage capacitors C22 is selected to have a very small internal resistance (ESR) to minimize the output voltage ripple.

4.9 Feedback and regulation

The output voltage is controlled using a TL431 (IC21). This device incorporates the voltage reference as well as the error amplifier and a driver stage. Compensation network C25, C26, R24, R25 and R26 constitutes the external circuitry of the error amplifier of IC21. This circuitry allows the feedback to be precisely matched to dynamically varying load conditions and provides stable control. The maximum current through the optocoupler diode and the voltage reference is set by using resistors R22 and R23. Optocoupler IC12 is used for floating transmission of the control signal to the “Feedback” input via capacitor C18. The optocoupler used meets DIN VDE 884 requirements for a wider creepage distance.

4.10 Active burst mode

At light load condition, the system enters into active burst mode. The entry and exit burst mode level can be selected in ICE3AR4780JG CoolSET™ by adding different capacitance values of capacitor at FBB pin. After entering into active burst mode, the controller is always active and thus the VCC must always be kept above the switch off threshold $V_{VCCoff} \geq 10.5$ V. During the active burst mode, the efficiency maintains in a very high level and at the same time it supports low ripple on V_{OUT} and fast response to load jump. To avoid mis-triggering of the burst mode, there is a 20ms internal blanking time. Once the FBB pin voltage drops below V_{FB_burst} , the internal blanking timer starts to count. When it reaches the built-in 20 ms blanking time, it then enters active burst mode.

During active burst mode, the current sense voltage limit is reduced from 1.06 V to V_{csth_burst} so as to reduce the conduction losses and audible noise. All the internal circuits are switched off except the reference and bias voltages to reduce the total VCC current consumption to below 0.62 mA. At active burst mode, the FBB voltage is changing like a sawtooth from 3.2 V to 3.5 V. To leave the active burst mode, FBB voltage must exceed 4 V. It will reset the active burst mode and turn the system into normal operating mode.

4.11 Jittering and soft gate drive

In order to reduce the emissions of electromagnetic interference (EMI) due to switching noise, the ICE3AR4780JG is implemented with frequency jittering, soft gate drive and 50 Ω gate turn on resistor. The jitter frequency is internally set to 100 kHz (± 4 kHz) and the jitter period is 4 ms.

4.12 Protection function

Protection is one of the major factors to determine whether the system is safe and robust. Therefore sufficient protection is necessary. ICE3AR4780JG provides all the necessary protections to ensure the system is operating safely. The protections include VCC over voltage, over load/open loop, VCC under voltage/short optocoupler, over temperature, external protection enable and brownout. When those faults are found, the system will go into auto restart which means the system will stop for a short period of time and restart again. If the fault persists, the system will stop again. It is then until the fault is removed, the system resumes to normal operation. A list of protections and the failure conditions are showed in the below table.

Circuit description

Table 2 Protection function of ICE3AR4780JG

Protection function	Failure condition	Protection Mode
Vcc Overvoltage	1. $V_{CC} > 20.5\text{ V}$ and $FB > 4.5\text{ V}$ & during soft start period 2. $V_{CC} > 25.5\text{ V}$	Odd skip Auto Restart
Overtemperature (controller junction)	$T_J > 130^\circ\text{C}$	Odd skip Auto Restart
Overload / Open loop	$V_{FBB} > 4.5\text{ V}$, last for 20 ms and extended blanking time (extended blanking time counted as 256 times of V_{BBA} charging and discharging from 0.9 V to 4.5V)	Odd skip Auto Restart
Vcc Undervoltage / Short Optocoupler	$V_{CC} < 10.5\text{ V}$	Auto Restart
Overtemperature (controller junction)	$T_J > 130^\circ\text{C}$	Odd skip non switch Auto Restart
External protection enable	$V_{AE} < 0.4\text{ V}$	Non switch Auto Restart
Brownout	$V_{BO_ref} < 0.9\text{ V}$ and last for 30 ~ 60 μs	Non switch Auto Restart

5 Circuit diagram

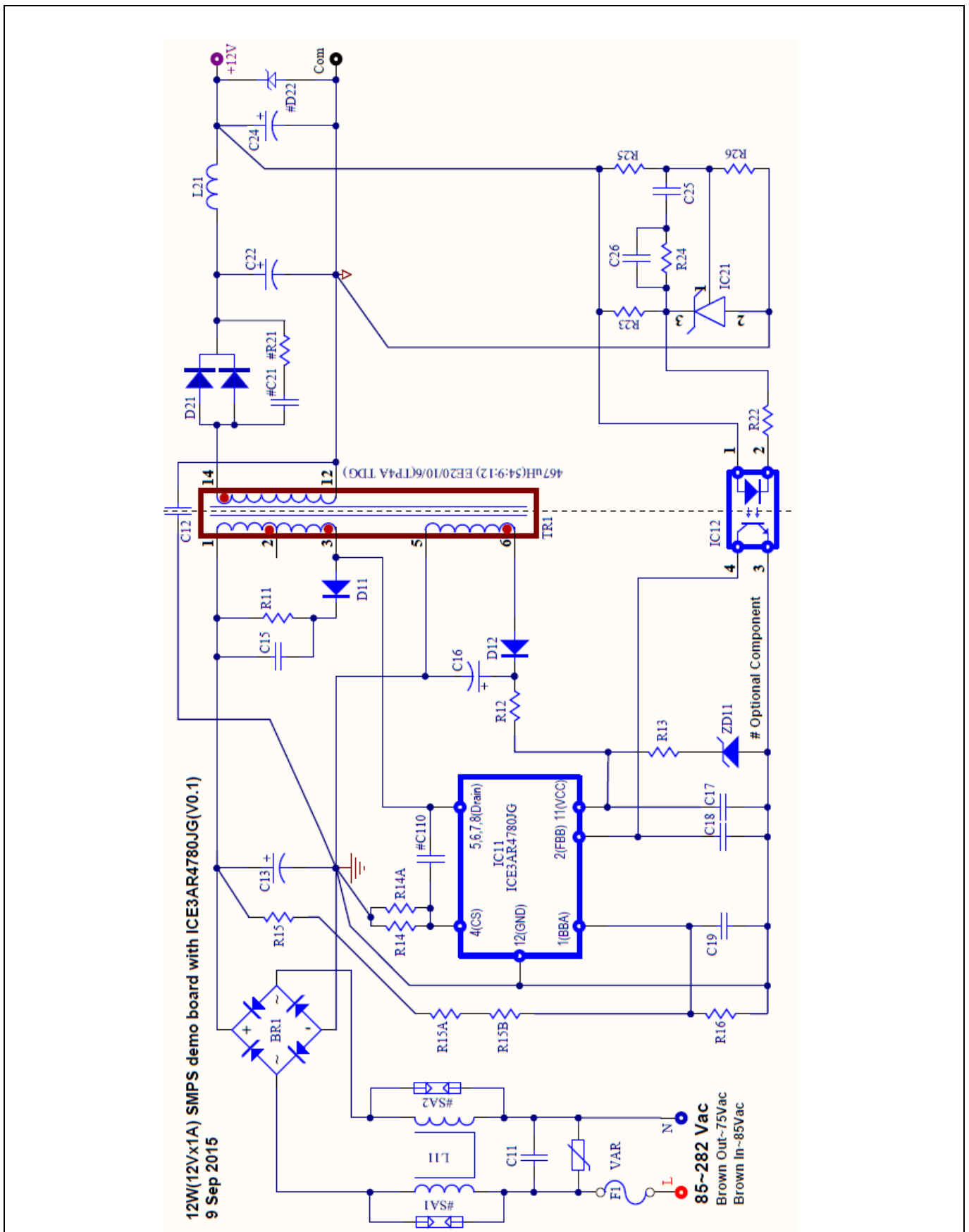

Figure 3 Schematic of DEMO-3AR4780JG

Circuit diagram

Note: General guideline for layout design of Printed Circuit Board (PCB):

1. Star ground at bulk capacitor C13: all primary grounds should be connected to the ground of bulk capacitor C13 separately in one point. It can reduce the switching noise going into the sensitive pins of CoolSET™ device effectively. The primary star ground can be split into five groups as follows,
 - i. Signal ground includes all small signal grounds connecting to the CoolSET™ GND pin such as filter capacitor ground C17, C18, C19 and opto-coupler ground.
 - ii. VCC ground includes the VCC capacitor ground C16 and the auxiliary winding ground, pin 5 of the power transformer.
 - iii. Current Sense resistor ground includes current sense resistor R14 and R14A.
 - iv. EMI return ground includes Y capacitor C12.
 - v. DC ground from bridge rectifier, BR1
2. Filter capacitor close to the controller ground: Filter capacitors, C17, C18 and C19 should be placed as close to the controller ground and the controller pin as possible so as to reduce the switching noise coupled into the controller.
3. High voltage traces clearance: High voltage traces should keep enough spacing to the nearby traces. Otherwise, arcing would incur.
 - i. 400 V traces (positive rail of bulk capacitor C13) to nearby trace: > 2.0 mm
 - ii. 600V traces (drain voltage of CoolSET™ IC11) to nearby trace: > 2.5 mm
4. Recommended minimum 232mm² copper area at drain pin to add on PCB for better thermal performance.
5. Power loop area (bulk capacitor C13, primary winding of the transformer TR1 (Pin 1 and 3), IC11 Drain pin, IC11 CS pin and current sense resistor R14/R14A) should be as small as possible to minimize the switching emission.

6 PCB layout

6.1 Top side

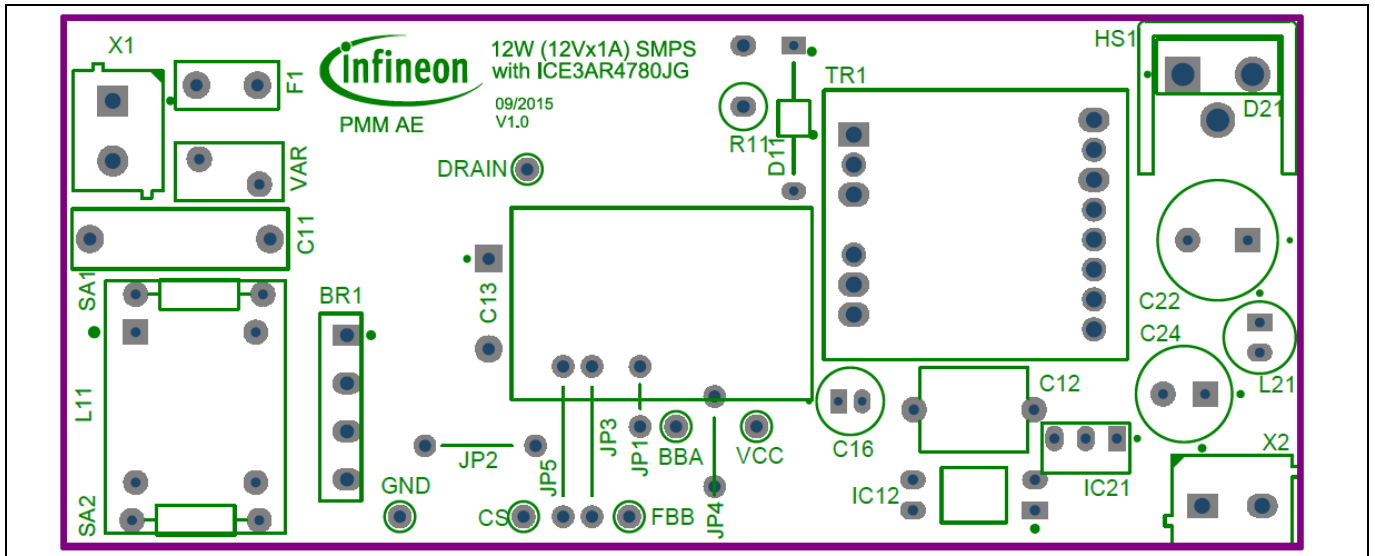

Figure 4 Top side component legend

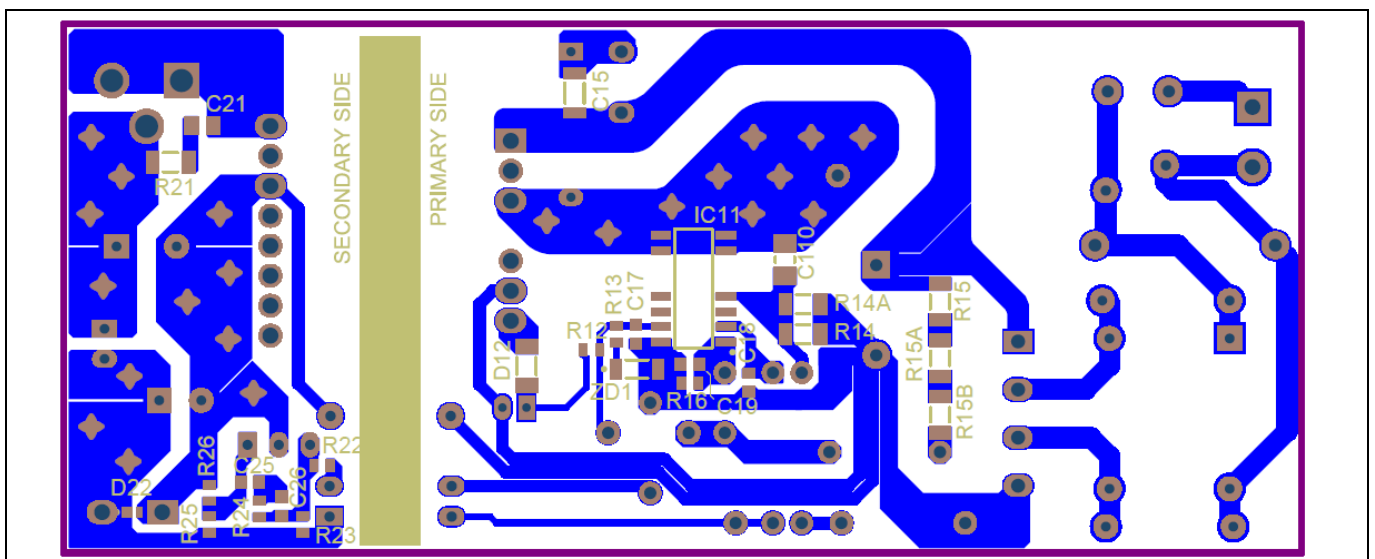

Figure 5 Bottom side copper and component legend

Bill of material

7 Bill of material

Table 3 Bill of material (V0.3)

No.	Designator	Description	Part Number	Manufacturer	Quantity
1	BR1	600V/1A	S1VBA60	Shindengen	1
2	C11	0.1 μ F/305V	B329221C3104K	Epcos	1
3	C12	2.2nF/250V	DE1E3KX222MA4BN01F	Murata	1
4	C13	33 μ F/450V	450BXC33MEFC16X25	Rubycon	1
5	C15	1nF/600V	GRM31A7U2J102JW31D9	Murata	1
6	C16	22 μ F/50V	50PX22MEFC5X11	Rubycon	1
7	C17	100nF/50V	GRM188R71H104KA93D	Murata	1
8	C18, C26	1nF/50V	GRM1885C1H102GA01D	Murata	2
9	C19	22nF/50V	GRM188R71H223KA01D	Murata	1
10	C22	1000 μ F/16V	16ZLH1000MEFC10X16	Rubycon	1
11	C24	680 μ F/16V	16ZLH680MEFC8X16	Rubycon	1
12	C25	220nF/50V	GRM188R71H224KAC4D	Murata	1
13	D11	0.8A/600V	D1NK60	Shindengen	1
14	D12	0.25A/200V	BAS21-03W	Infineon	1
15	D21	30A/100V	STPS30M100SFP		1
16	F1	1.6A/300V	36911600000		1
17	HS1	Heat Sink(D21)	577202B00000G		1
18	IC11	ICE3AR4780JG	ICE3AR4780JG	Infineon	1
19	IC12	SFH617A-3(DIP-4)	SFH617A-3		1
20	IC21	TL431BVLPG(T0-92)	TL431BVLPG		1
21	L11	68mH/0.4A	B82731M2401A033	Epcos	1
22	L21	2.2 μ H/4.3A	744 746 202 2	Würth Electronics	1
23	R11	150k Ω /2W/500V	PR02000201503JR500		1
24	R12	10 Ω (0603)			1
25	R13	10 Ω (0603)			1
26	R14	2.7 Ω /0.33W/1206/ \pm 1%	ERJ8BQF2R7V		1
27	R14A	2.4 Ω /0.33W/1206/ \pm 1%	ERJ8BQF2R4V		1
28	R15	1.8M Ω /1%/1206			1
29	R15A, R15B	1M Ω /1%/1206			2
30	R16	43k Ω /1%(0603)			1
31	R22	820 Ω /0603			1
32	R23	1.2k Ω /0603			1
33	R24	68k Ω /0603			1
34	R25	38k Ω /1%/0603			1
35	R26	10k Ω /1%/0603			1
36	TR1	467 μ H (54:9:12)	750343050	Würth Electronics	1
37	Test point	BBA,FBB,CS,Drain,Vcc,Gnd			1
38	VAR	0.25W/300V	B72207S2301K101	Epcos	1
39	ZD1	22V Zener	UDZS22B		1
40	(L N), (+12V Com)	Connector	691102710002(WE)	Würth Electronics	2

Transformer construction

8 Transformer construction

Core and material: EE20/10/6(EF20), TP4A (TDG)

Bobbin: 14-Pins, THT, horizontal version (070-5643)

Primary Inductance: $L_P = 467 \mu\text{H}$ ($\pm 10\%$), measured between pin 1 and pin 3

Manufacturer and part number: Würth Electronics Midcom (750343050)

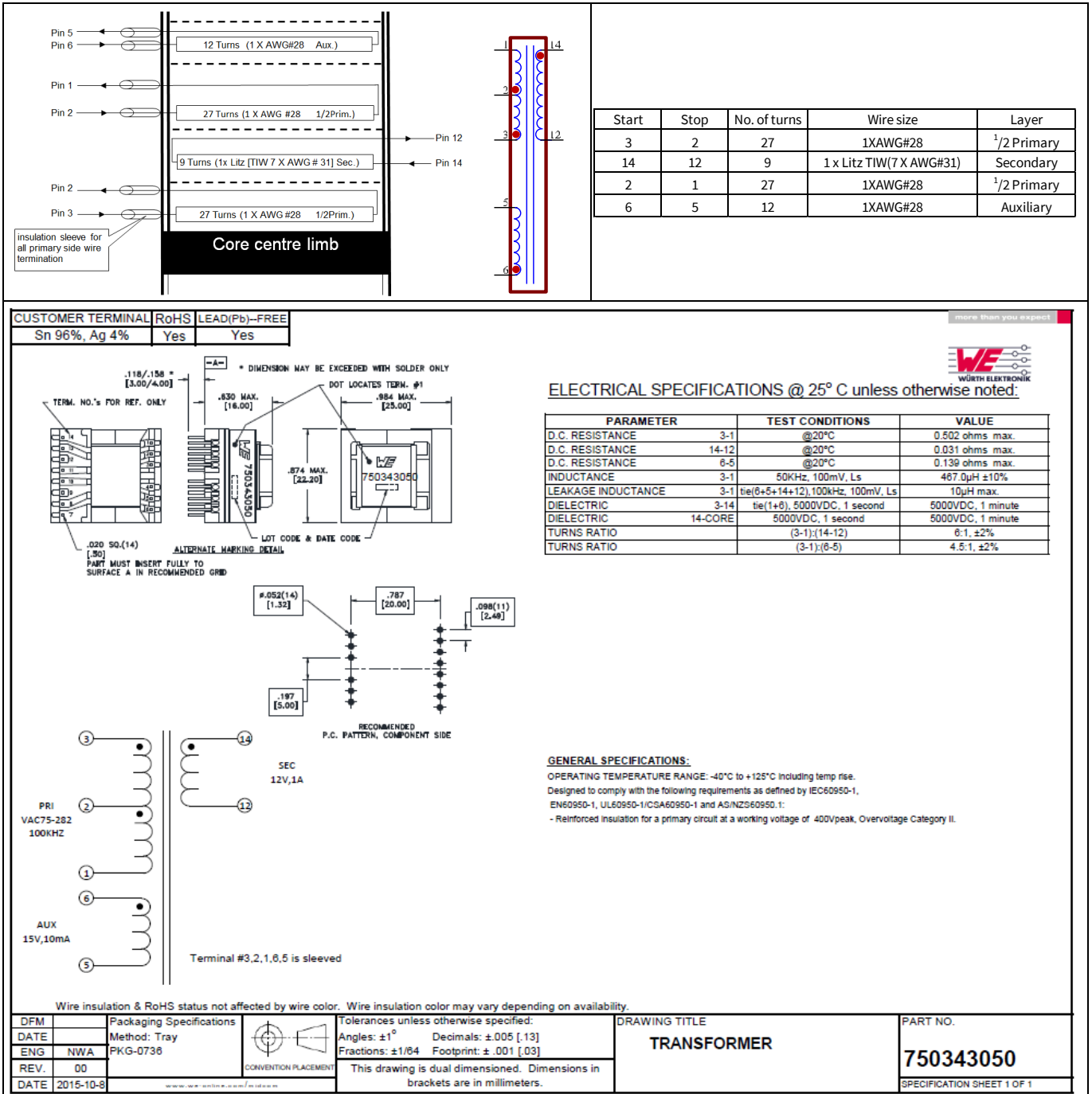

Figure 6 Transformer structure

Test results

9 Test results

9.1 Efficiency, regulation and output ripple

Table 4 Efficiency, regulation and output ripple

Input (V _{AC} /Hz)	P _{in} (W)	V _{out} (V _{DC})	I _{out} (A)	V _{OutRPP} (mV)	P _{out} (W)	Efficiency (η) (%)	Average η (%)	OLP P _{in} (W)	OLP I _{out} (A)
85 V _{AC} /60 Hz	0.03679	12.06	0.00	21.96	/	/	/	15	1.02
	1.54	12.06	0.10	28.67	1.21	78.31	/		
	3.65	12.06	0.25	8.22	3.02	82.60	83.45		
	7.13	12.06	0.50	11.2	6.03	84.57			
	10.77	12.06	0.75	14.13	9.05	83.98			
	14.59	12.06	1.00	22.62	12.06	82.66			
115 V _{AC} /60 Hz	0.04050	12.06	0.00	22.36	/	/	/	14.68	1.03
	1.56	12.06	0.10	29.2	1.21	77.31	/		
	3.64	12.06	0.25	8.18	3.02	82.83	84.90		
	7.03	12.06	0.50	11.16	6.03	85.78			
	10.54	12.06	0.75	13.42	9.05	85.82			
	14.16	12.06	1.00	16.84	12.06	85.17			
230 V _{AC} /50 Hz	0.06769	12.06	0.00	25.38	/	/	/	15.29	1.09
	1.58	12.06	0.10	33.91	1.21	76.33	/		
	3.80	12.06	0.25	8.84	3.02	79.34	84.24		
	7.12	12.06	0.50	11.47	6.03	84.69			
	10.48	12.06	0.75	13.38	9.05	86.31			
	13.92	12.06	1.00	15.29	12.06	86.64			
282 V _{AC} /50 Hz	0.09027	12.06	0.00	28.27	/	/	/	15.98	1.14
	1.67	12.06	0.10	36.71	1.21	72.22	/		
	3.94	12.06	0.25	8.71	3.02	76.52	82.17		
	7.31	12.06	0.50	11.51	6.03	82.49			
	10.71	12.06	0.75	13.2	9.05	84.45			
	14.15	12.06	1.00	15.16	12.06	85.23			

Test results

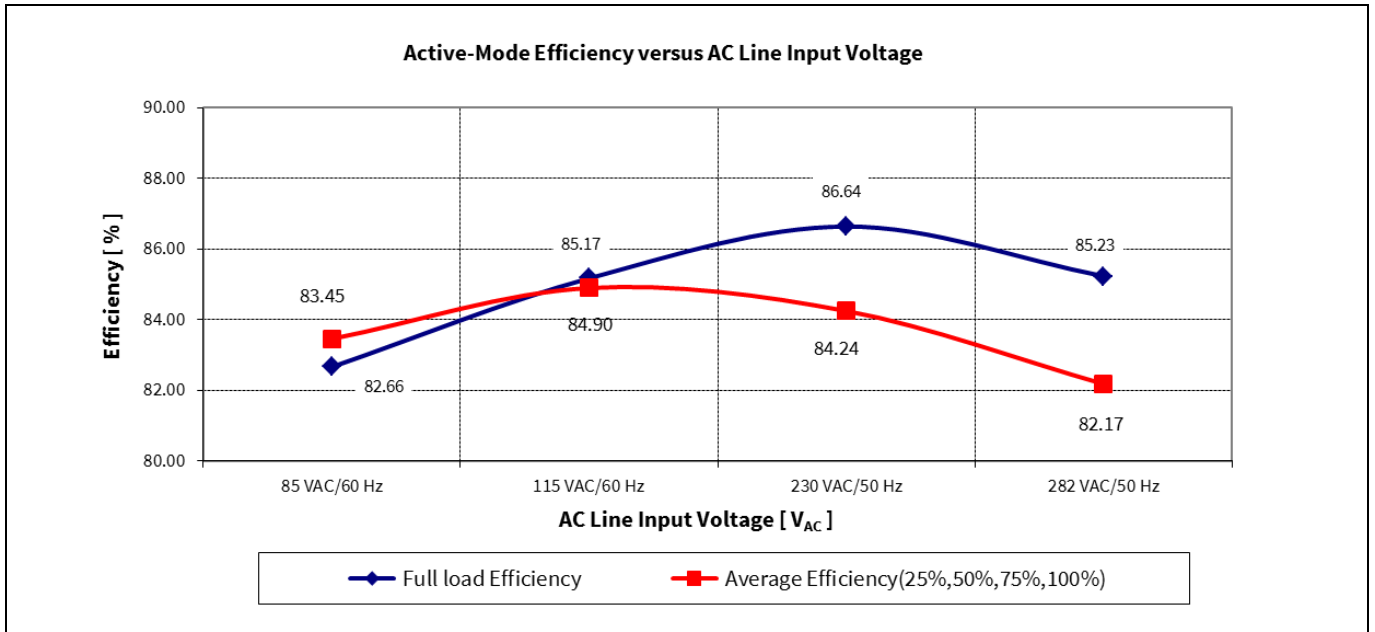

Figure 7 Efficiency vs AC line input voltage

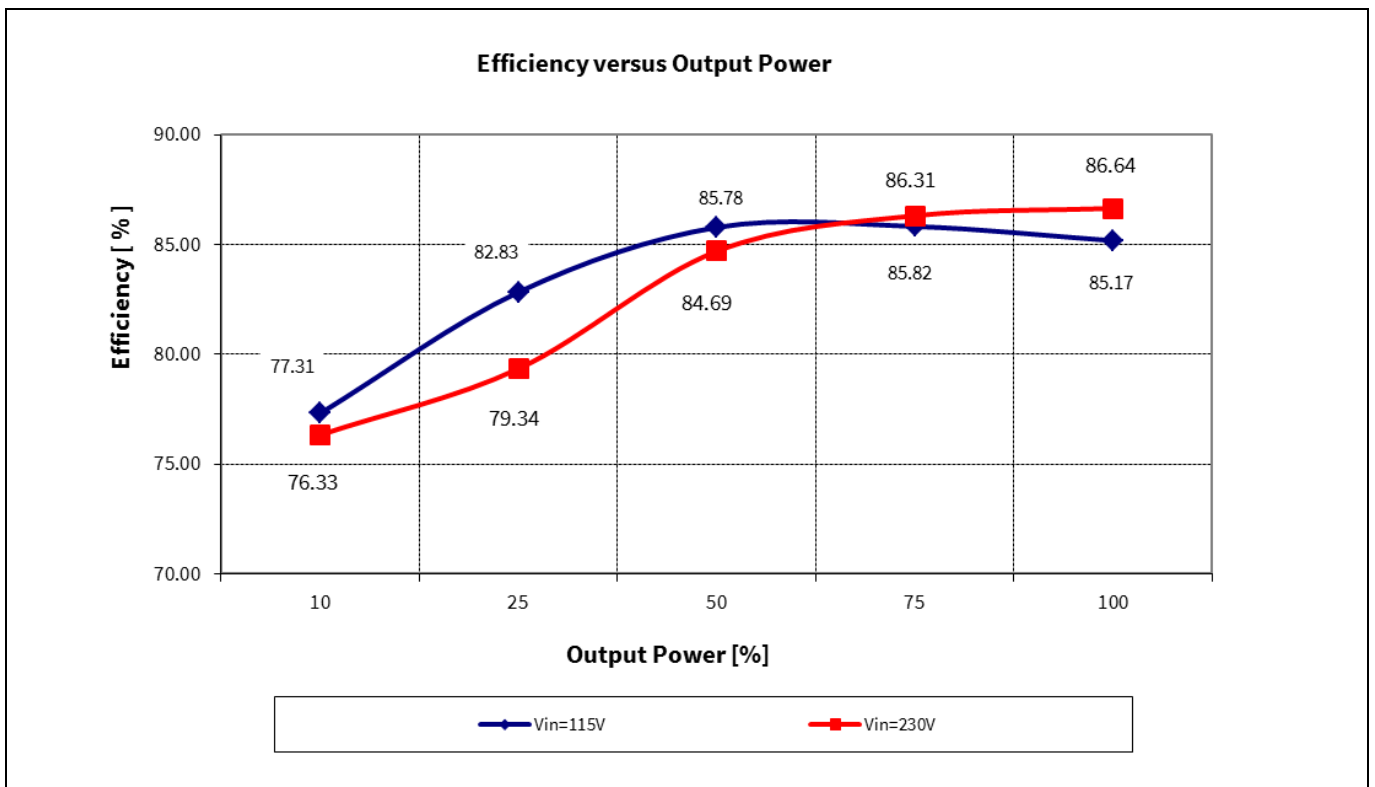

Figure 8 Efficiency vs output power at 115 V_{AC} and 230 V_{AC} line

Test results

9.2 Standby power

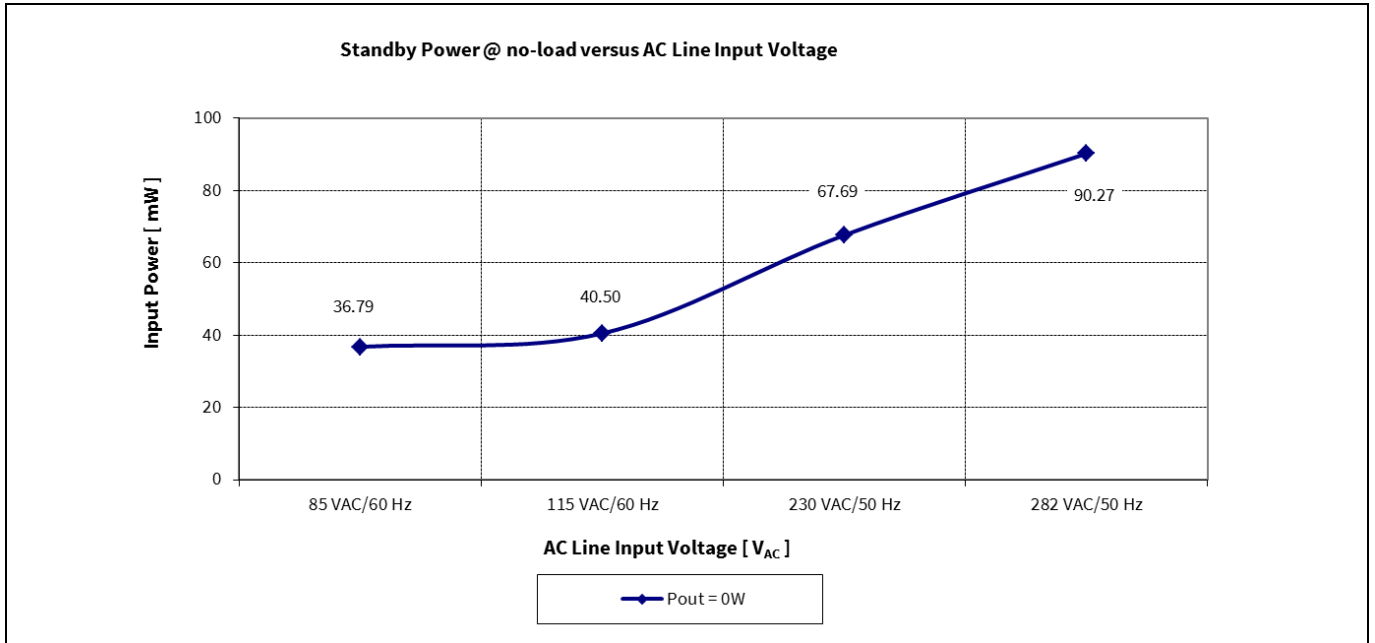

Figure 9 Standby power at no load vs AC line input voltage (measured by Yokogawa WT210 power meter - integration mode)

9.3 Line regulation

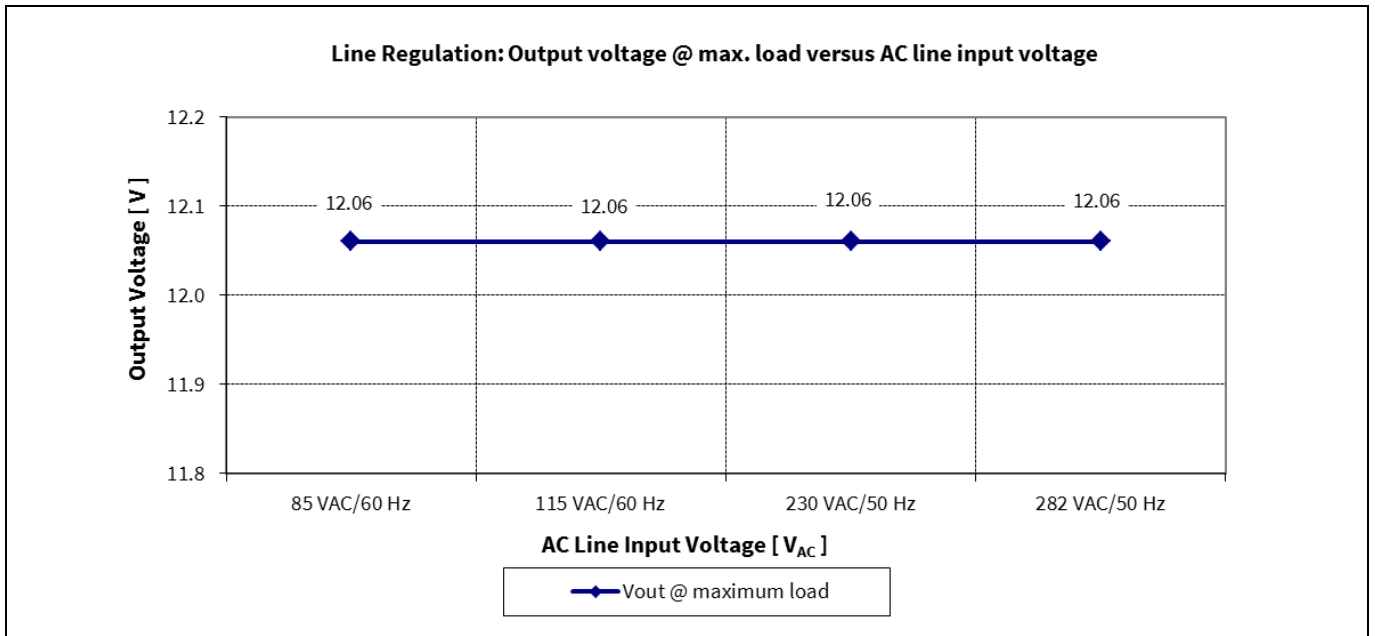

Figure 10 Line regulation Vout at full load vs AC line input voltage

Test results

9.4 Load regulation

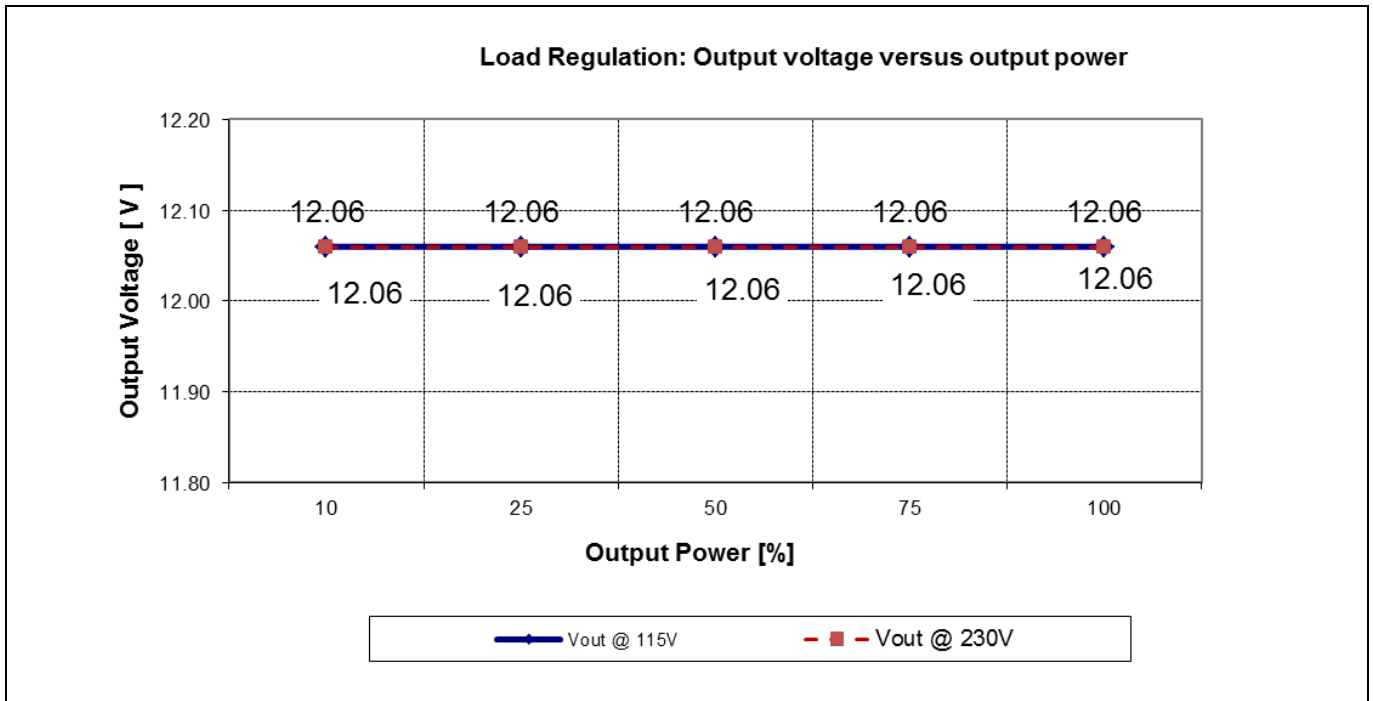

Figure 11 Load regulation V_{out} vs output power

9.5 Maximum input power

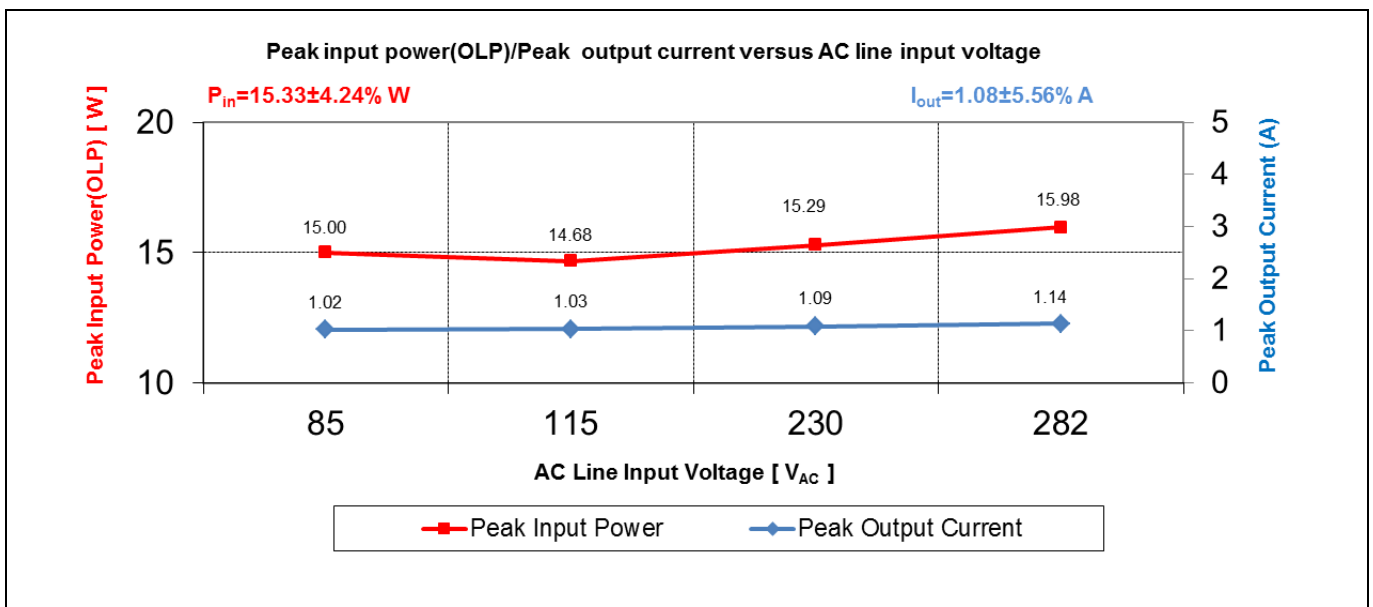

Figure 12 Maximum input power (before over-load protection) vs AC line input voltage

9.6 ESD immunity (EN61000-4-2)

Pass EN61000-4-2 Special Level (± 16 kV for both contact and air discharge).

9.7 Surge immunity (EN61000-4-5)

Pass EN61000-4-5 Installation class 4 (± 2 kV for line to line and ± 4 kV for line to earth).

Test results

9.8 Conducted emissions (EN55022 class B)

The conducted EMI was measured by Schaffner (SMR4503) and followed the test standard of EN55022 (CISPR 22) class B. The demo board was set up at maximum load (12 W) with input voltage of 115 V_{AC} and 230 V_{AC}.

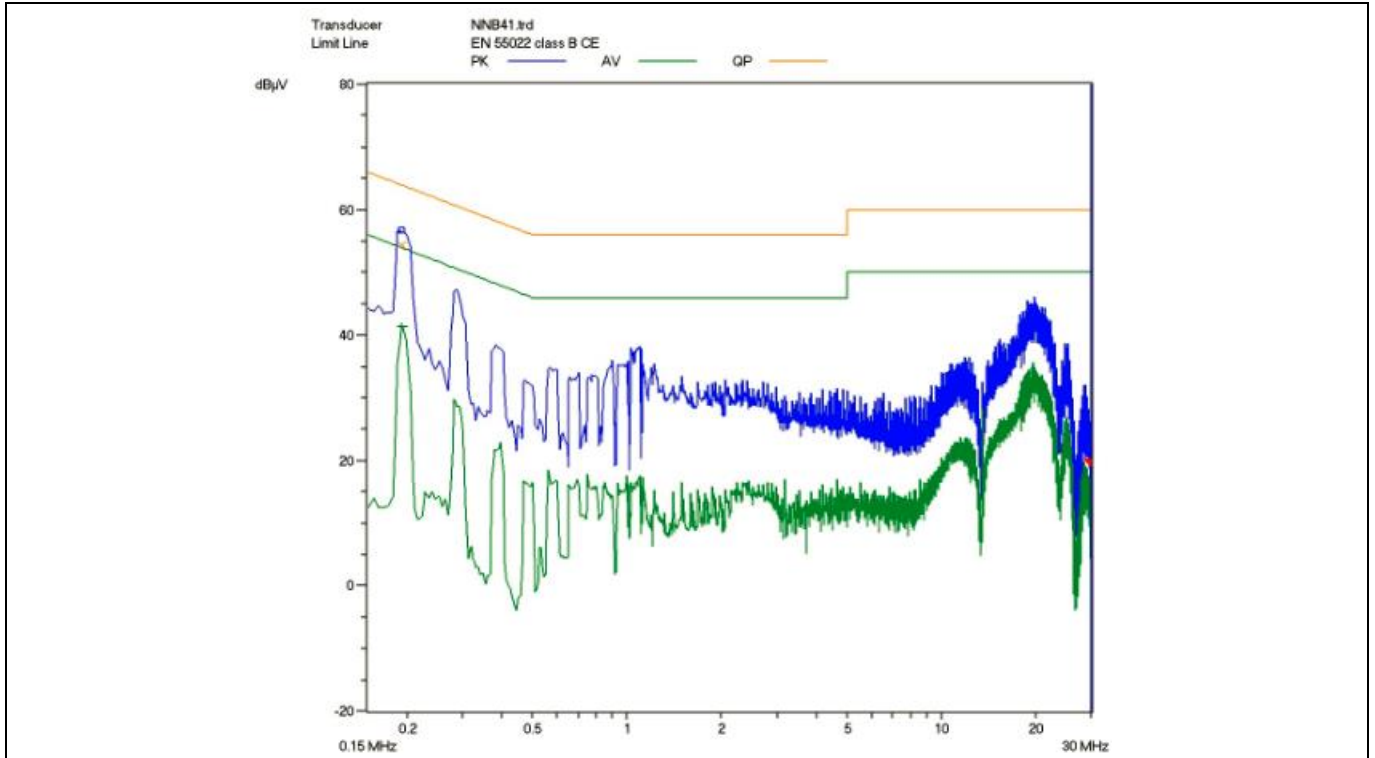

Figure 13 Conducted emissions(Line) at 115 V_{AC} and maximum Load

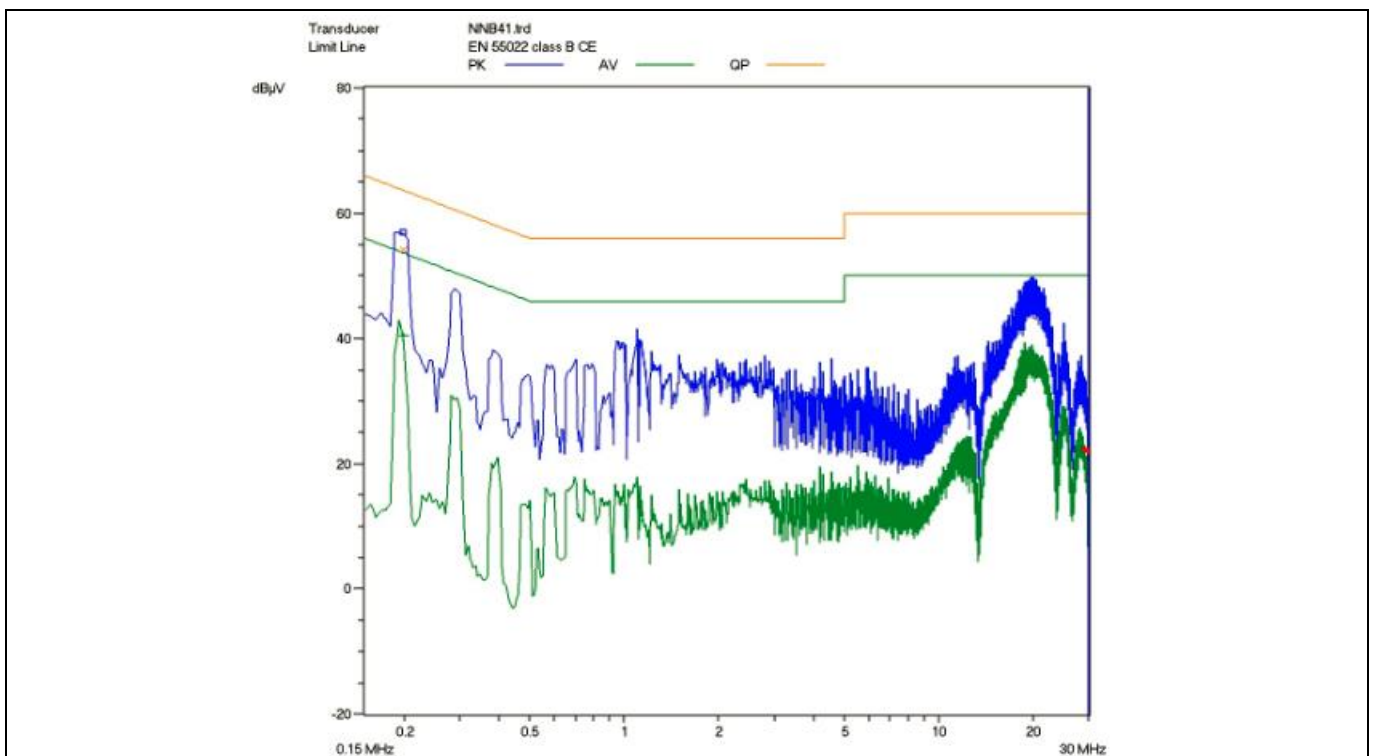

Figure 14 Conducted emissions(Neutral) at 115 V_{AC} and maximum Load

Test results

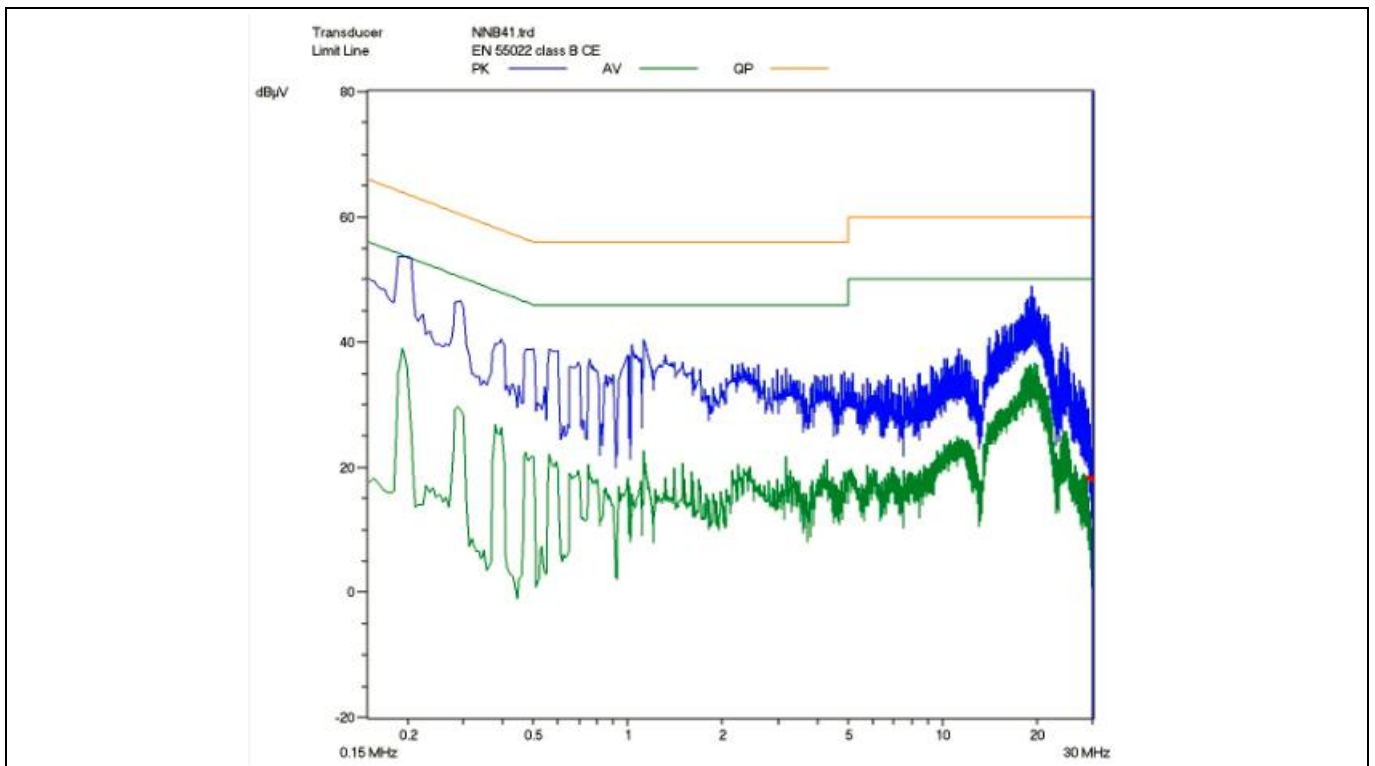

Figure 15 Conducted emissions(line) at 230 V_{AC} and maximum Load

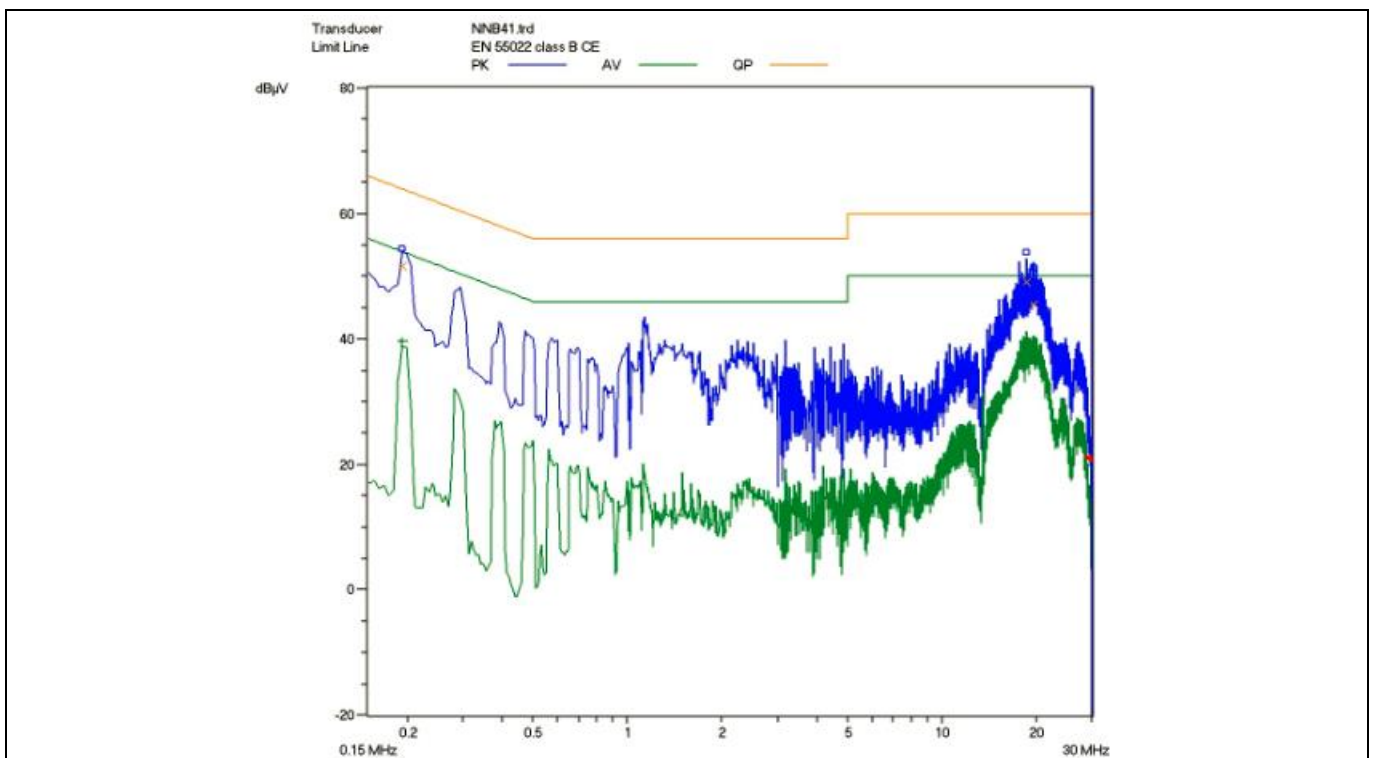

Figure 16 Conducted emissions(Neutral) at 230 V_{AC} and maximum Load

Pass conducted emissions EN55022 (CISPR 22) class B with 9 dB margin for quasi peak limit.

Test results

9.9 Thermal measurement

The thermal test of open frame demo board was done using an infrared thermography camera (TVS-500EX) at ambient temperature 25°C. The measurements were taken after two hours running at full load.

Table 5 Hottest temperature of demo board

No.	Major component	85 V _{AC} (°C)	282 V _{AC} (°C)
1	IC11 (ICE3AR4780JG)	62.1	59.1
2	R14 (current sense resistor)	37.7	37.9
3	TR1 (transformer)	43.5	47.0
4	BR1 (bridge diode)	46.3	33.8
5	R11(clamper resistor)	40.9	39.7
6	L11 (EMI choke)	59.2	32.0
7	D21 (secondary diode)	41.4	41.7
8	Ambient	25	25

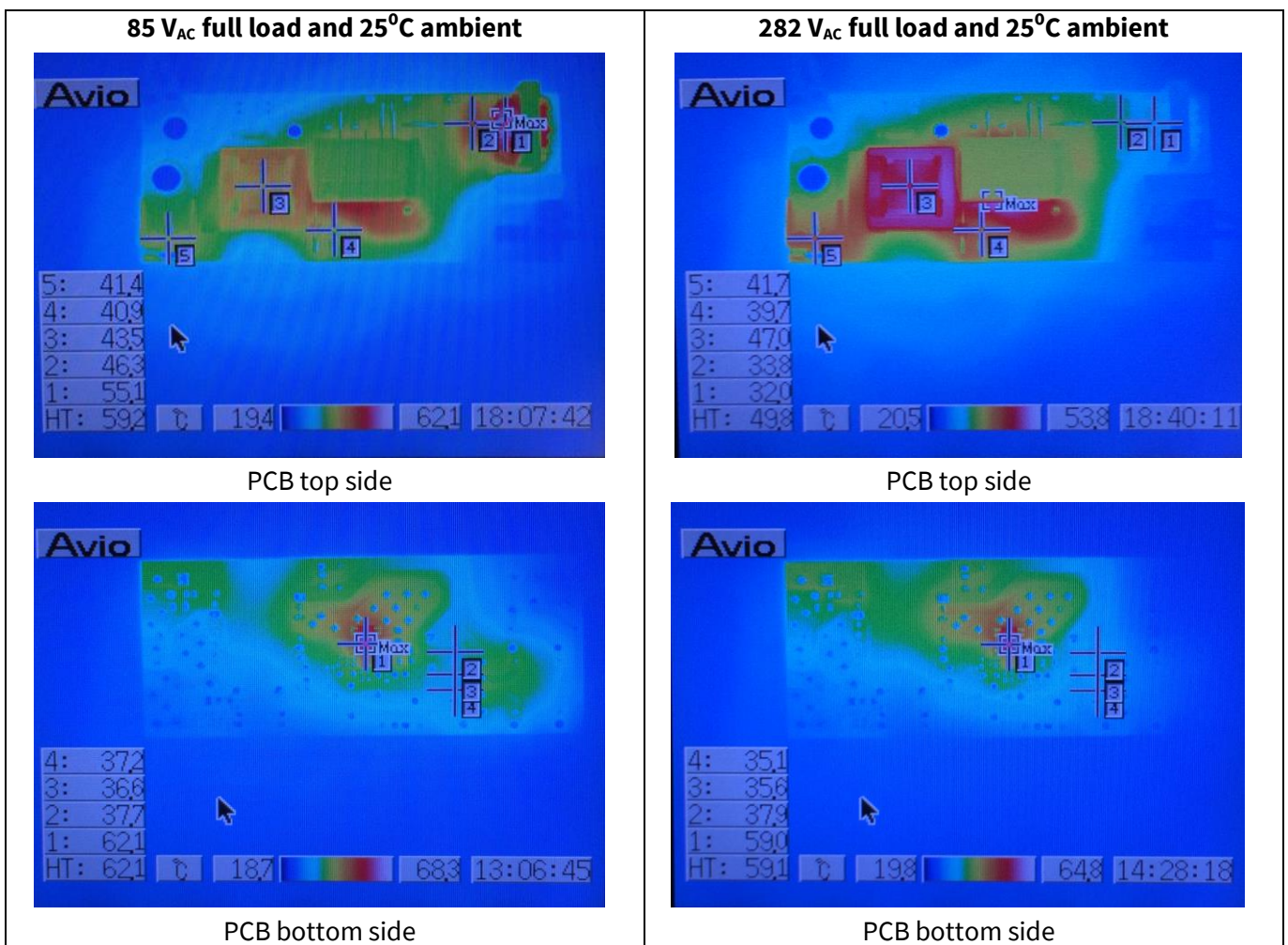

Figure 17 Infrared thermal image of DEMO-3AR4780JG

Waveforms and scope plots

10 Waveforms and scope plots

All waveforms and scope plots were recorded with a TELEDYNELECROY 606Zi oscilloscope.

10.1 Startup at low/high AC line input voltage with maximum load

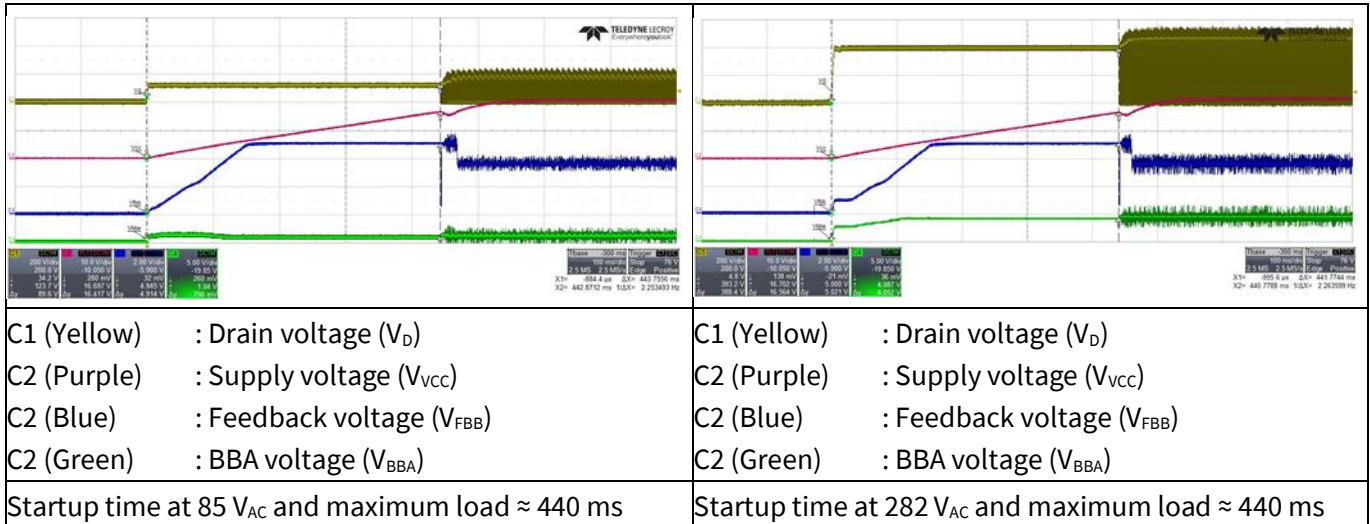

Figure 18 Startup

10.2 Soft start

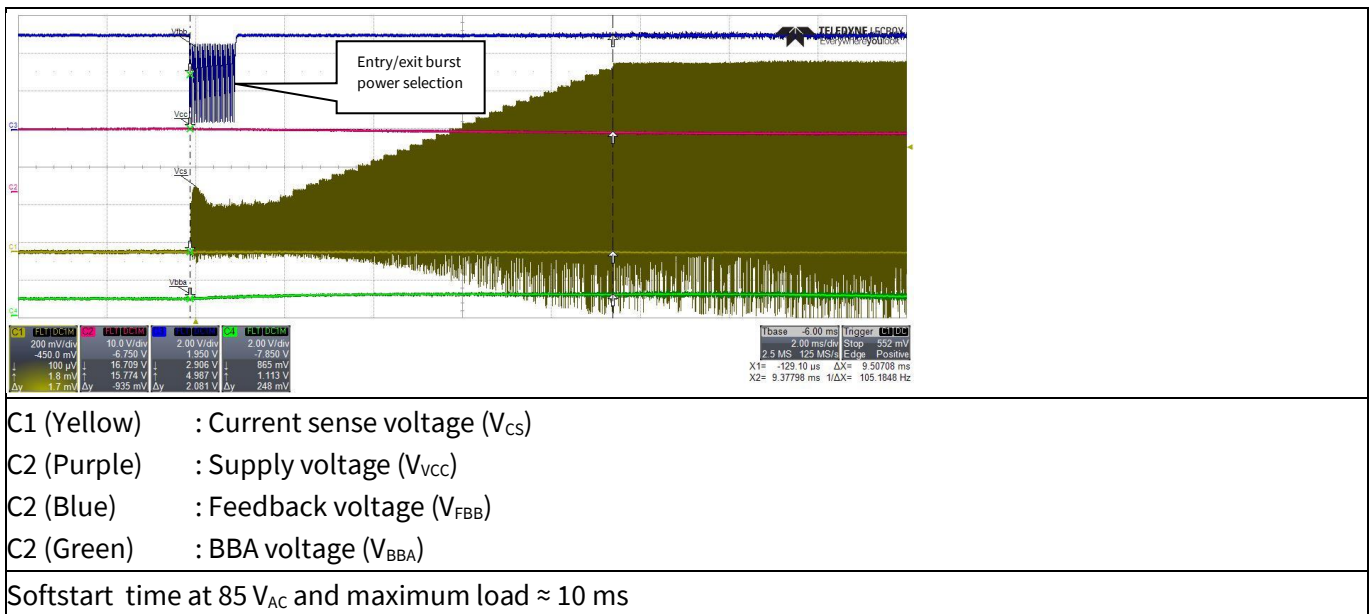
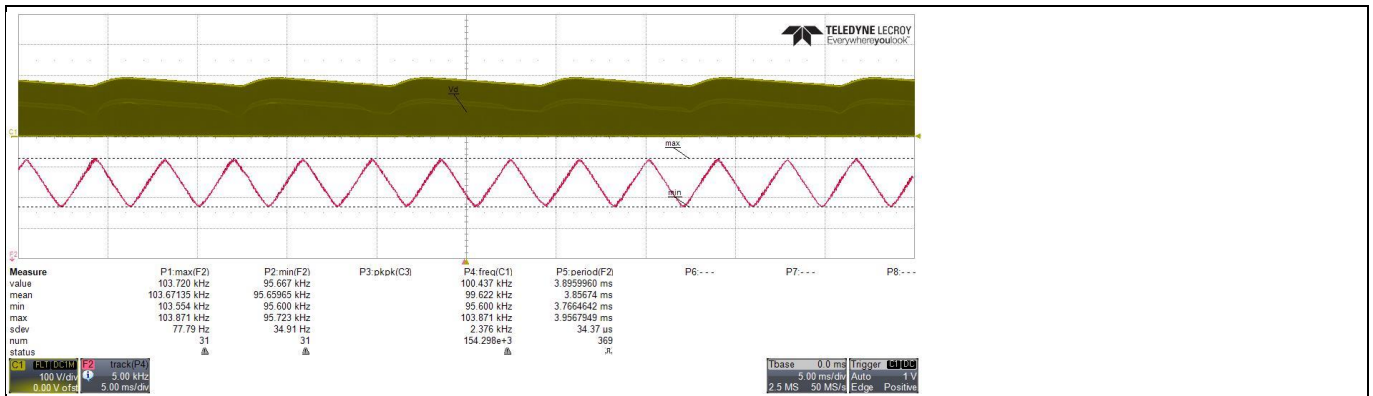

Figure 19 Startup

Waveforms and scope plots

10.3 Frequency jittering



C1 (Yellow) : Drain voltage (V_{Drain})

F1 (Yellow) : Frequency track of C1

Frequency jittering at 85 V_{AC} and maximum load \approx 95 kHz ~ 103 kHz, Jitter period is \approx 4 ms

Figure 20 Frequency jittering

10.4 Drain and current sense voltage at maximum load

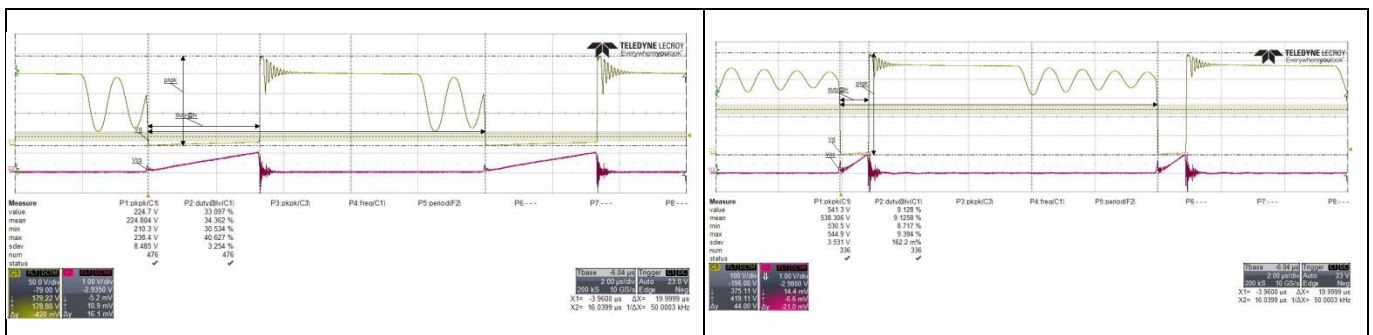

C1 (Yellow) : Drain voltage (V_{Drain})

C2 (Purple) : Current sense voltage (V_{CS})

At 85 V_{AC} : V_{Drain_peak} at \approx 240 V
: On duty cycle \approx 40%

C1 (Yellow) : Drain voltage (V_{Drain})

C2 (Purple) : Current sense voltage (V_{CS})

At 282 V_{AC} : V_{Drain_peak} at \approx 545 V
: On duty cycle \approx 9.4%

Figure 21 Drain and current sense voltage at maximum load

Waveforms and scope plots

10.5 Load transient response (Dynamic load from 10% to 100%)

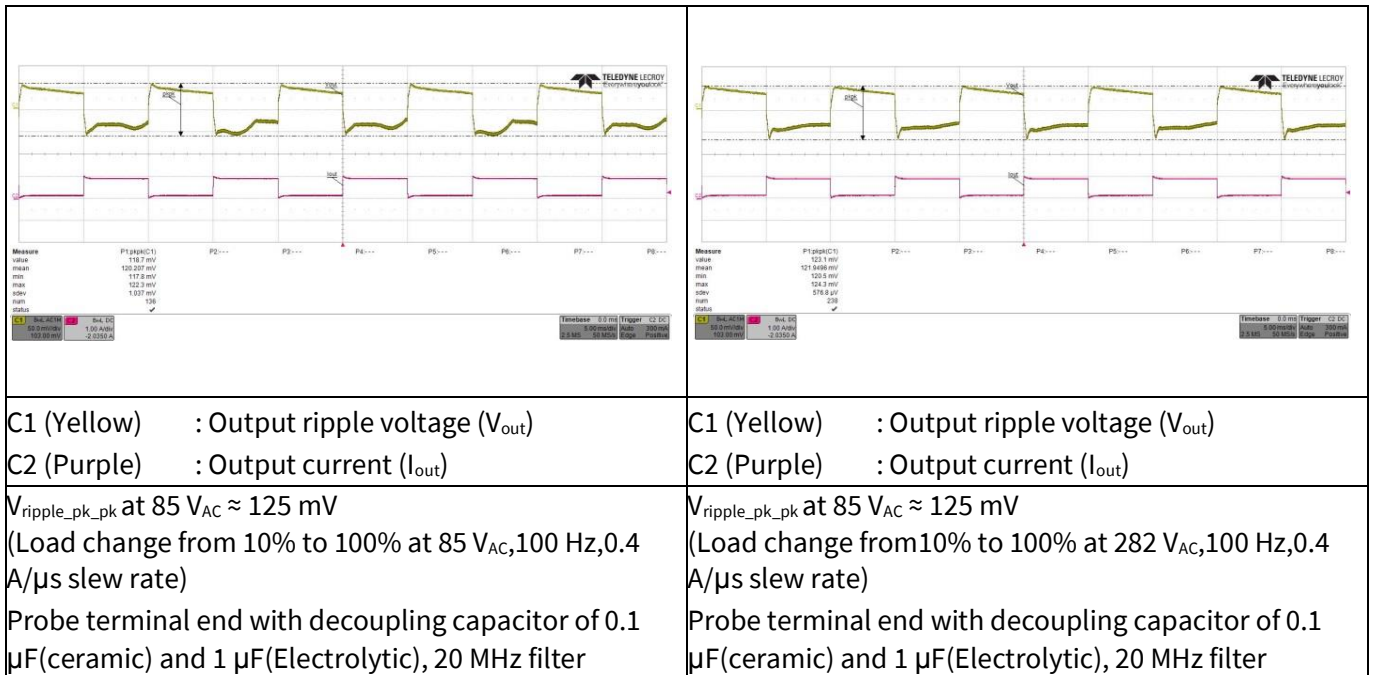

Figure 22 Load transient response

10.6 Output ripple voltage at maximum load

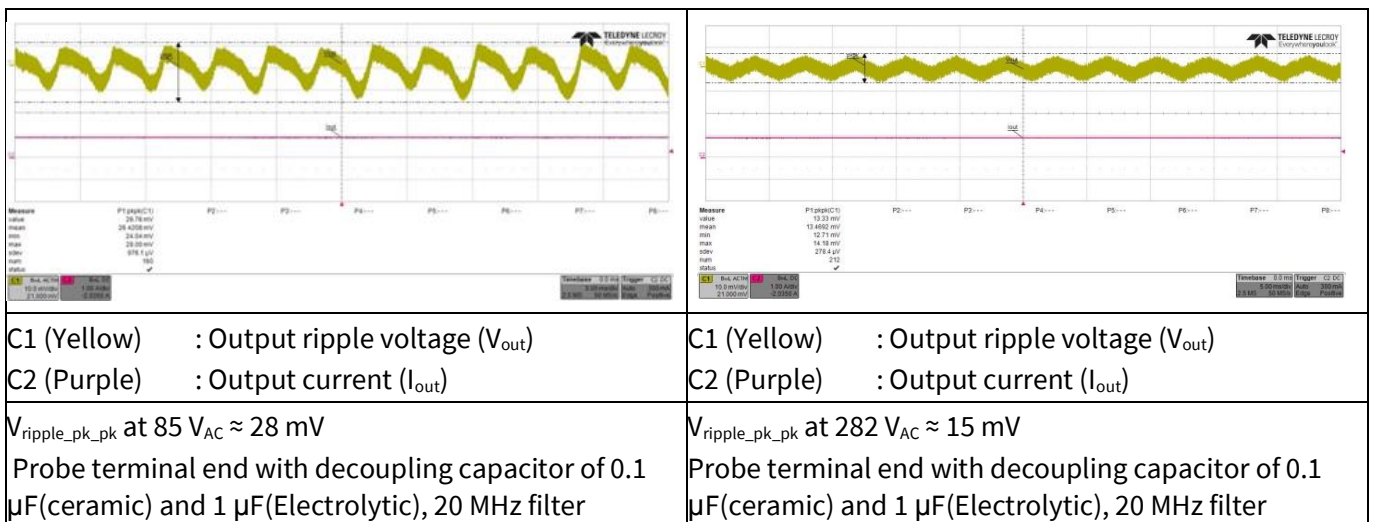

Figure 23 Output ripple voltage at maximum load

Waveforms and scope plots

10.7 Output ripple voltage at burst mode 1 W load

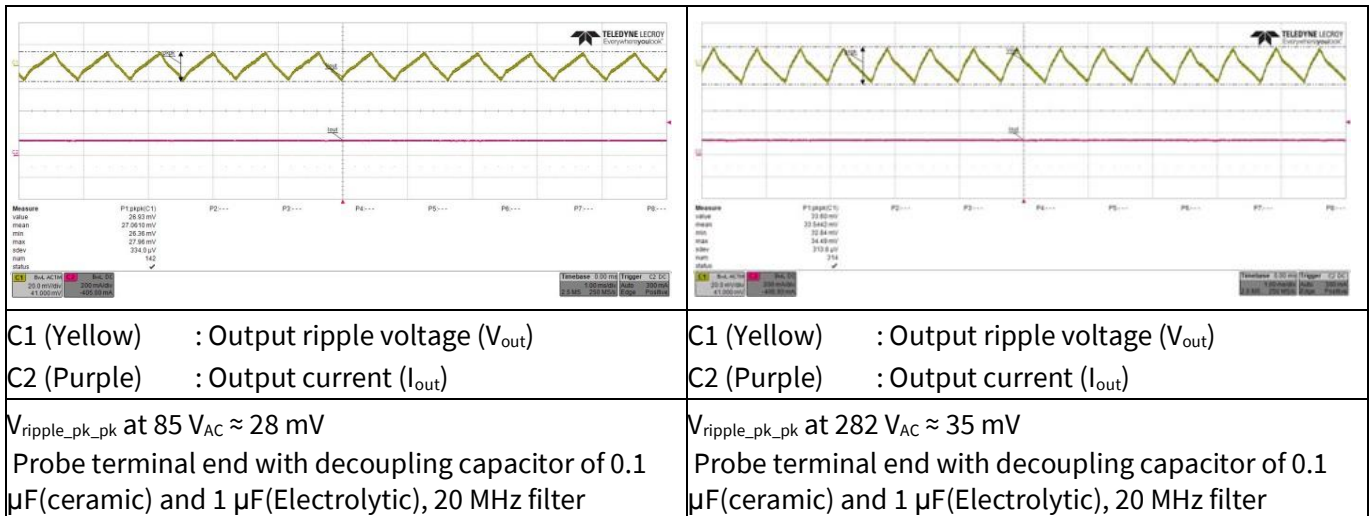

Figure 24 Output ripple voltage at burst mode 1 W load

10.8 Active burst mode

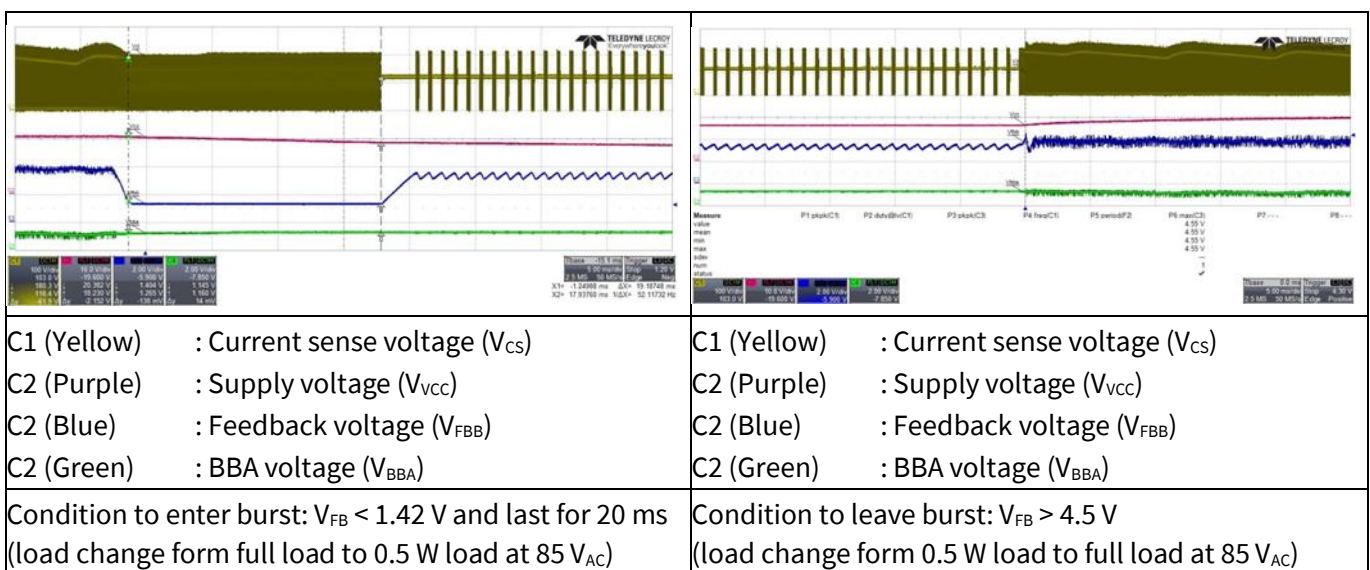
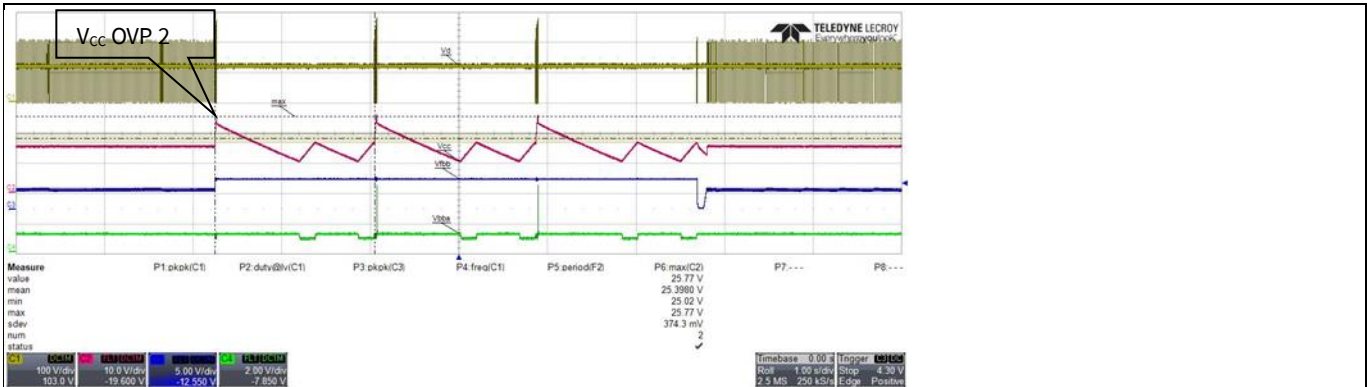

Figure 25 Active burst mode

Waveforms and scope plots

10.9 VCC over voltage protection (Odd skip auto restart mode)



- C1 (Yellow) : Drain voltage (V_D)
- C2 (Purple) : Supply voltage (V_{CC})
- C2 (Blue) : Feedback voltage (V_{FB})
- C2 (Green) : BBA voltage (V_{BBA})

Condition to enter VCC over voltage protection: $V_{CC} > 25.5\text{ V}$ ($V_{CC}\text{ OVP 2}$)
 $V_{CC} > 20.5\text{ V}$ and $V_{FB} > 4.5\text{ V}$ and during soft start ($V_{CC}\text{ OVP 1}$)
 (Short the diode of optocoupler(Pin 1 and 2 of IC12) during system operating at no load and 85 V_{AC})

Figure 26 VCC overvoltage protection

10.10 Over load protection (Odd skip auto restart mode)

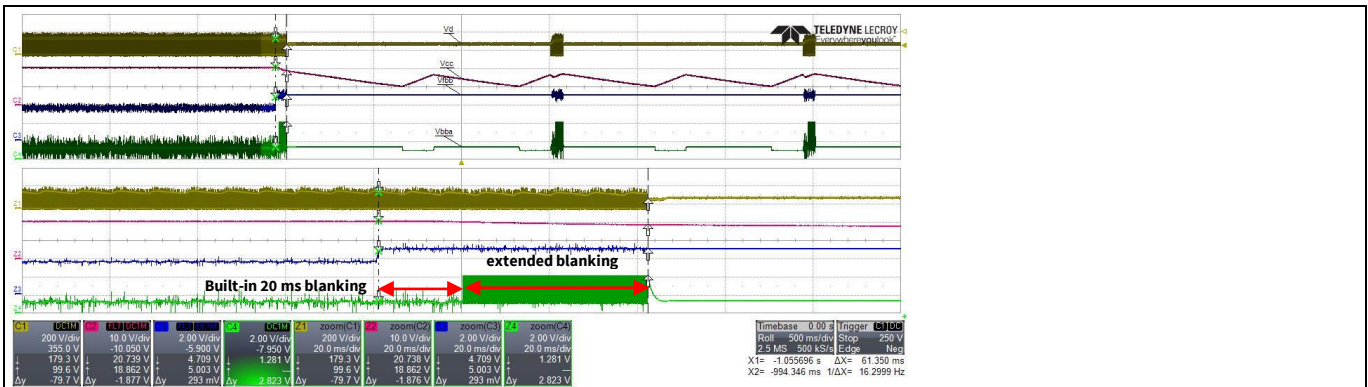

- C1 (Yellow) : Drain voltage (V_D)
- C2 (Purple) : Supply voltage (V_{CC})
- C2 (Blue) : Feedback voltage (V_{FB})
- C2 (Green) : BBA voltage (V_{BBA})

Condition to enter over load protection: $V_{FB} > 4.5\text{ V}$, last for 20 ms and extended blanking time
 (output load change from 1 A to 1.5 A at 85 V_{AC})

Figure 27 Over load protection

Waveforms and scope plots

10.11 VCC under voltage/Short optocoupler protection (Auto restart mode)

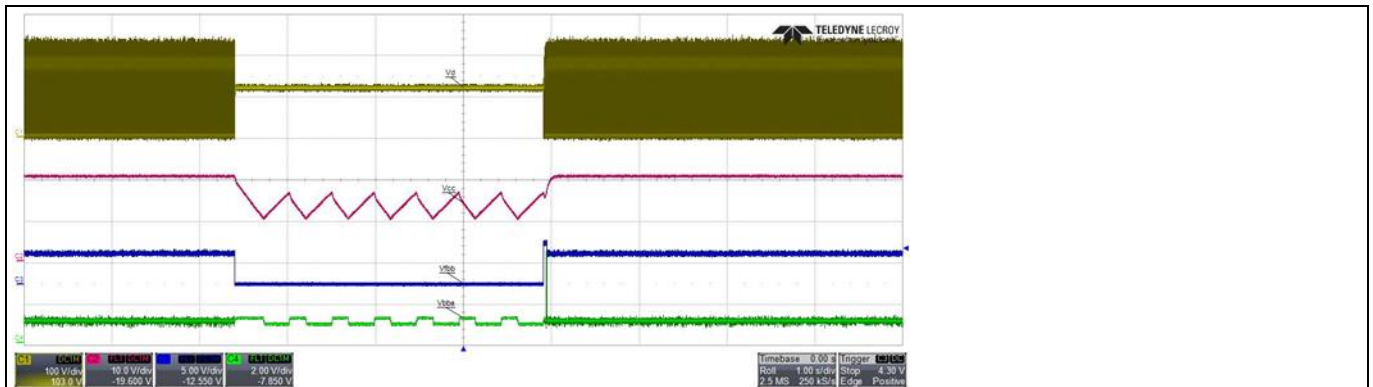

- C1 (Yellow) : Drain voltage (V_D)
- C2 (Purple) : Supply voltage (V_{VCC})
- C2 (Blue) : Feedback voltage (V_{FB})
- C2 (Green) : BBA voltage (V_{BBA})

Condition to enter VCC under voltage protection: $V_{CC} < 10.5\text{ V}$
 (short the transistor of optocoupler(Pin 3 and 4 of IC12) during system operating at full load and release at 85 V_{AC})

Figure 28 VCC under voltage/short optocoupler protection

10.12 External protection enable (Non switch auto restart mode)

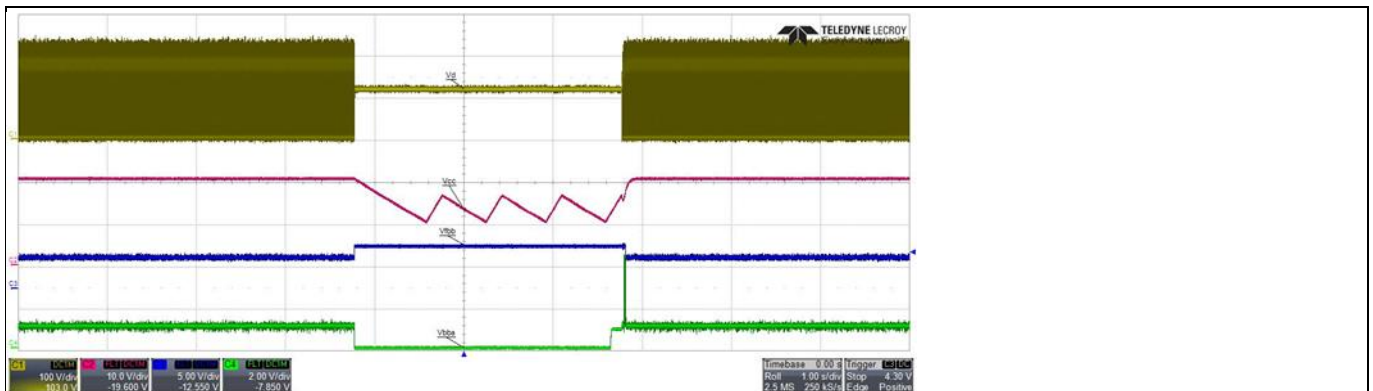

- C1 (Yellow) : Drain voltage (V_D)
- C2 (Purple) : Supply voltage (V_{VCC})
- C2 (Blue) : Feedback voltage (V_{FB})
- C2 (Green) : BBA voltage (V_{BBA})

Condition to enter external protection enable: $V_{BBA} < 0.4\text{ V}$
 (short BBA pin to Gnd by 10 Ω resistor during system operating at full load and 85 V_{AC})

Figure 29 External protection enable

Waveforms and scope plots

10.13 Brownout Mode (Non switch auto restart mode)

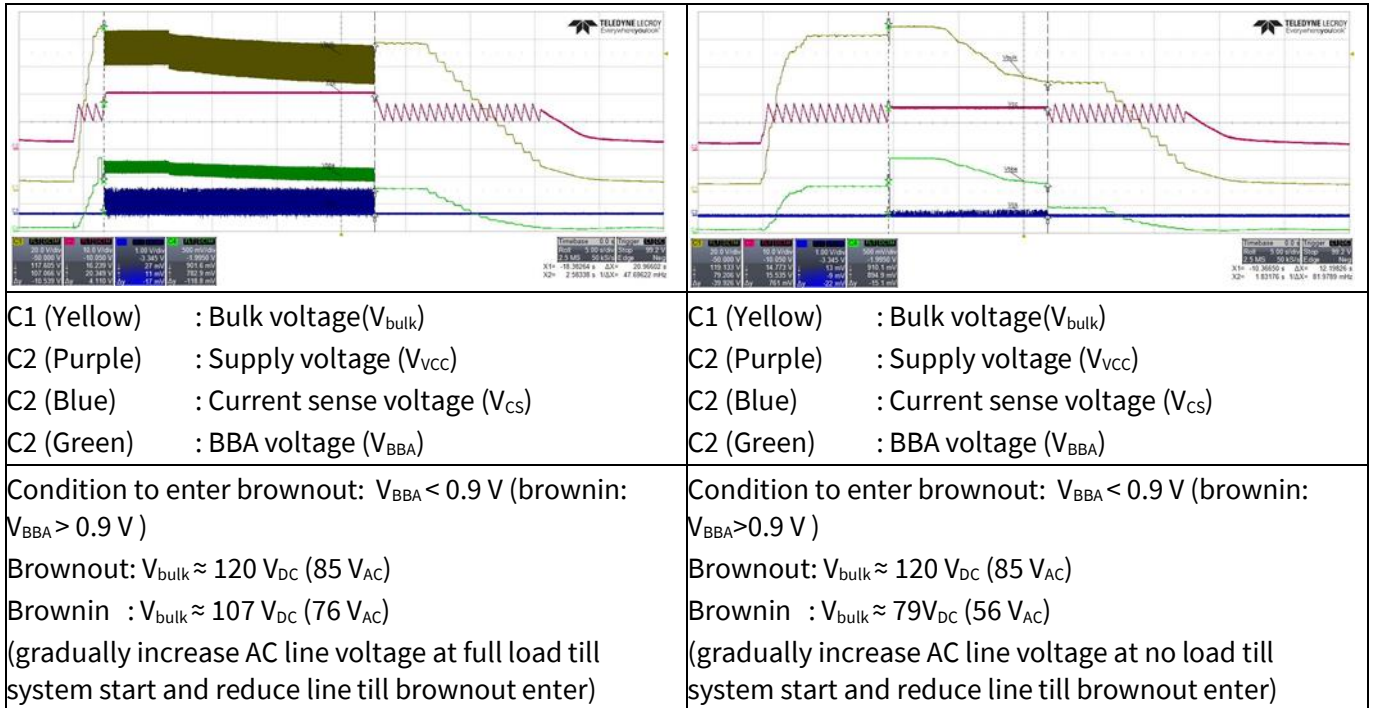

Figure 30 Brownout mode



References

11 References

- [1] [ICE3AR4780JG datasheet, Infineon Technologies AG](#)
- [2] [AN-PS0044-CoolSET F3R80 DIP-7 brownout/input OVP and frequency jitter version design guide-V1.5](#)

Revision History

Major changes since the last revision

Page or Reference	Description of change
--	First release.

Trademarks of Infineon Technologies AG

AURIX™, C166™, CanPAK™, CIPOS™, CoolGaN™, CoolMOS™, CoolSET™, CoolSiC™, CORECONTROL™, CROSSAVE™, DAVE™, DI-POL™, DrBlade™, EasyPIM™, EconoBRIDGE™, EconoDUAL™, EconoPACK™, EconoPIM™, EiceDRIVER™, eupec™, FCOS™, HITFET™, HybridPACK™, Infineon™, ISOFACE™, IsoPACK™, i-Wafer™, MIPAQ™, ModSTACK™, my-d™, NovalithIC™, OmniTune™, OPTIGA™, OptiMOS™, ORIGA™, POWERCODE™, PRIMARION™, PrimePACK™, PrimeSTACK™, PROFET™, PRO-SiL™, RASIC™, REAL3™, ReverSave™, SatRIC™, SIEGET™, SIPMOS™, SmartLEWIS™, SOLID FLASH™, SPOC™, TEMPFET™, thinQ!™, TRENCHSTOP™, TriCore™.

Trademarks updated August 2015

Other Trademarks

All referenced product or service names and trademarks are the property of their respective owners.

Edition 2016-04-15

Published by

Infineon Technologies AG

81726 Munich, Germany

© 2016 Infineon Technologies AG.

All Rights Reserved.

Do you have a question about this document?

Email: erratum@infineon.com

Document reference

ANDEMO_201510_PL21_005

IMPORTANT NOTICE

The information contained in this application note is given as a hint for the implementation of the product only and shall in no event be regarded as a description or warranty of a certain functionality, condition or quality of the product. Before implementation of the product, the recipient of this application note must verify any function and other technical information given herein in the real application. Infineon Technologies hereby disclaims any and all warranties and liabilities of any kind (including without limitation warranties of non-infringement of intellectual property rights of any third party) with respect to any and all information given in this application note.

The data contained in this document is exclusively intended for technically trained staff. It is the responsibility of customer's technical departments to evaluate the suitability of the product for the intended application and the completeness of the product information given in this document with respect to such application.

For further information on the product, technology, delivery terms and conditions and prices please contact your nearest Infineon Technologies office (www.infineon.com).

WARNINGS

Due to technical requirements products may contain dangerous substances. For information on the types in question please contact your nearest Infineon Technologies office.

Except as otherwise explicitly approved by Infineon Technologies in a written document signed by authorized representatives of Infineon Technologies, Infineon Technologies' products may not be used in any applications where a failure of the product or any consequences of the use thereof can reasonably be expected to result in personal injury.