



Durant Industrial Controls

Product Focus

You name it...
we can control it,
measure it, monitor it
and count it.



Innovative Control Solutions



Component leads are formed prior to insertion into PCBs.

Since 1879, the single dedicated focus of Durant® products has been: Provide dependable and innovative industrial control solutions to the global marketplace.

More than a century ago, Durant started with the development and application of mechanical counters for use in flour production. The Durant product meter quickly became the standard across all industries. Even today, the simple, but effective, technology developed and patented by Walter Durant is still being used. The spirit of innovation has sustained Durant's growth. The company has adapted to, and helped define, new market needs. Today, Durant is a leading engineering and manufacturing operation providing intelligent machine controls, as well as traditional mechanical and electromechanical counters.

Functional Orientation

Our broad range of products is grouped according to the functional needs you have. We know that you come to us with needs, not model numbers.

Custom Questions Require Custom Answers

Since every Durant customer is one-of-a-kind, we address product and service needs in the same spirit. We are an effective solution provider, a quality product developer, and a manufacturer. Our top-drawer engineering staff understands the intricacies of the field. Their superior skills go into every new product innovation and every customer need. Durant solutions can be supplied as stand-alone products or integrated into a system.

Making You More Productive

Our operation is set up to be convenient and helpful to you.

Durant has an international sales network, a readily available application and market management engineering staff, and a workplace ethic that supports seeking the best solution for your needs. Our Watertown, Wisconsin facility is ISO® 9001 and ISO 14000 certified and committed to leading-edge manufacturing processes such as just-in-time, statistical process control and continuous flow. Quality, precision, trouble-free performance, durability, and ease-of-operation have all been

Our Design Engineers use state-of-the-art AutoCAD technology.



Durant goals transformed into our basic operating principles.

Whether you are looking for proprietary OEM components, a modification to an existing product, or a standard replacement, we're here and committed to increasing your productivity.



Axial and radial insertion is incorporated into the continuous flow board assembly line.



Final assembly of Durant products includes quality control inspections.

Table of Contents

Pages 4 – 6
Totalizers — Electronic

Pages 7 – 9
Totalizers —
Mechanical and
Electromechanical

Pages 10 – 12
Count Controls —
Electronic

Page 13
Count Controls —
Electromechanical

Pages 14 – 15
Ratemeters

Pages 16 – 17
Timers

Pages 18 – 19
Digital Panel Meters

Pages 20 – 21
Flow Totalizers/
Transmitters
and Controls

Pages 22 – 23
Temperature
Controls/Indicators

Pages 24 – 25
Special Function
Controls

Pages 26 – 29
Specialty Products

Pages 30 – 33
Transducers

Pages 34 – 35
Accessories — Solid-
State Relays

Pages 36 – 39
Accessories — Other

Totalizers — Electronic

Totalizers are used in a wide variety of applications where accurate totals are needed. Typical applications include counting the number of parts produced, amount of material used, or the number of

machine cycles occurring. Totalizers are the simplest and most common type of counter. As an added bonus, some models can perform both totalizing and rate meter functions.



E402400

Battery Powered, Compact, LCD Totalizer

- 8-digit, LCD display, 7 mm (0.28") high characters
- 10 kHz maximum count input frequency
- Uni-directional and bi-directional models
- High voltage pulse and quadrature adapter accessories, see **Page 38**
- Front panel and remote reset capability
- Lithium battery (10-year typical life), nonreplaceable
- Battery included
- Front panel reset active or disabled and remote reset capability
- NEMA® 4 front panel
- CE marked



53300400

Battery Powered, LCD Display

- 8-digit, high visibility, LCD display, 10.8 mm (0.43") high characters
- 0 – 10 kHz count speed with solid-state input
- Uni-directional and bi-directional models
- Front panel reset active or disabled and remote reset capability
- 3 V lithium battery (5-year typical life), user replaceable
- Battery included
- Rear-panel screw terminals
- Programmable decimal point and count scaling on select models
- Optional backlit display
- NEMA 4X front panel
- CE marked
- Extended temperature model available
- Key reset available



57701480

ac/dc Powered, LED Totalizers

- 6-digit, LED display, 14 mm (0.56") high characters
- 1/TAU rate indicator included
- Count and rate scaling
- 12 Vdc, 75 mA maximum output power
- Removable screw terminals
- Accepts 85 – 265 Vac; 9 – 30 Vdc models available
- Optional RS-485 communications
- Optional analog output
- NEMA 4X front panel
- UL®, cUL® listed
- CE marked
- For configuration software, see "ProFile", **Page 37**

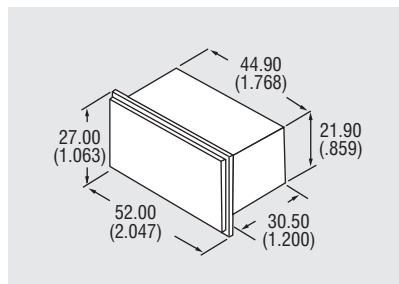

Panel Cutout: 22 x 45 (0.870 x 1.772)
Approximate in mm (inches).

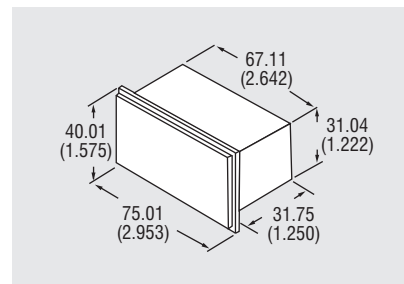

Panel Cutout: 33 x 68 (1.299 x 2.677)
Approximate in mm (inches).

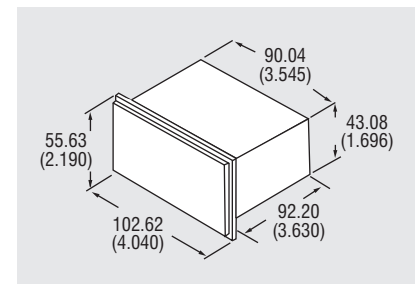

Panel Cutout: 45 x 92 (1.772 x 3.622)
Approximate in mm (inches).



57601400

ac/dc Powered, 2-Line LCD Display

- 8-digit, high visibility, backlit 7.5 mm (0.3") high characters
- 1/TAU rate indicator included
- Programmable decimal point and count and rate scaling
- 12 Vdc ($\pm 25\%$) at 100 mA output power
- Removable screw terminals
- Front panel reset and remote reset capability
- Accepts 115 Vac; 230 Vac and 10 – 15 Vdc models available
- NEMA 4X front panel
- UL, CSA® listed
- CE marked
- For configuration software, see "ProFile", Page 37

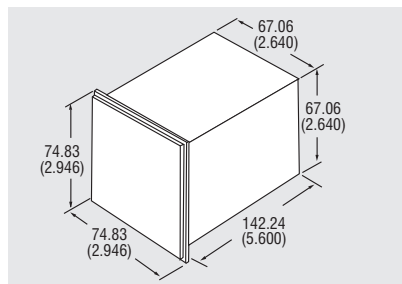

Panel Cutout: 68 x 68 (2.677 x 2.677)
Approximate in mm (inches).



58811400

Traditional Full Featured, ac/dc Powered, LED Display

- 8-digit, LED display, 14 mm (0.56") high characters
- Programmable decimal point and count and rate scaling
- 15 Vdc at 100 mA output power
- Rear panel screw terminals
- Front panel reset and remote reset capability
- Accepts 115/230 Vac and 11 – 28 Vdc power
- Optional, 1/TAU rate indicator
- NEMA 4 front panel
- UL, CSA listed
- CE marked

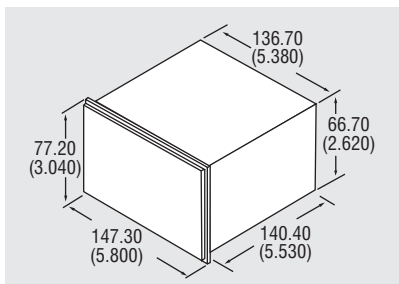

Panel Cutout: 68 x 138 (2.677 x 5.433)
Approximate in mm (inches).



57810400

Basic Pulse Count, LED Display

- 7-digit, LCD display, 14 mm (0.56") high characters
- Programmable decimal point rate scaling
- 15 Vdc, 85 mA maximum output power
- Rear-panel screw terminals
- Front panel and remote reset capability
- Accepts 115 or 230 Vac, 11 – 30 Vdc power
- NEMA 4 front panel

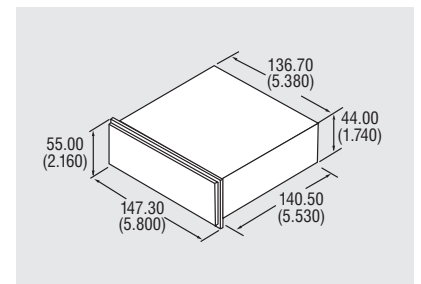

Panel Cutout: 45 x 138 (1.770 x 5.430)
Approximate in mm (inches).

Totalizers — Electronic (continued)

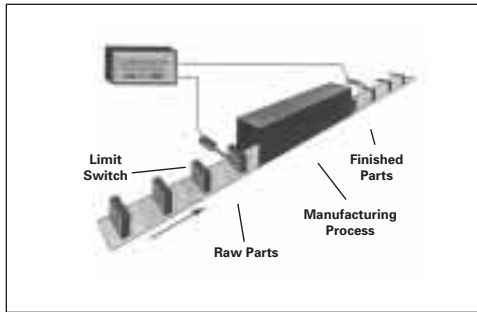

Add/Subtract

Parts are fed into a machine or process, an operation is performed, and the finished parts exit the machine or process. The add/subtract totalizer is used to indicate the number of parts in process. A sensor at the start of the process provides a pulse to add the input of the totalizer. When a part leaves the machine, the end of the process, a sensor provides a pulse to the subtract input of the totalizer.

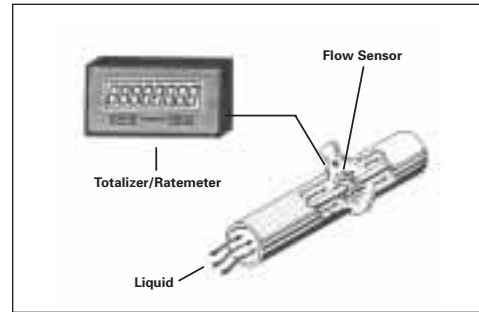

Flow Quantity and Rate Indication

In many processes, it is desirable to know both the total quantity of product produced and the rate at which the product is being produced.

The output of a turbine flow sensor is connected to a totalizer/ratemeter. The flow sensor produces a known number of pulses per gallon (or other unit of measure). The counter scales each pulse to make the totalizer and ratemeter indicate the desired units of measure.

ELECTRONIC TOTALIZERS SELECTION CHART

Order Number	Count Digits	Scaling	Rate Digits	Programmable Decimal	Description
Battery Powered, Compact, LCD Totalizer					
E402400 ①	8				Totalizer — Uni-directional (Count Up)
E402410 ①	8				Totalizer — Bi-directional (Count with Direction)
Battery Powered, LCD Display					
53300400 ①	8				8-Digit Totalizer
53300401 ①	8	•		•	Add/Subtract (Solid-State Input)
53300402 ①	8	•		•	Add/Subtract (Contact Input)
53300403 ①	8	•		•	Quadrature Totalizer
53300405 ①	8	•	4/5	•	Totalizer, 1/TAU Ratemeter
53301475 ①	8	•	4/5	•	Totalizer/Ratemeter with Magnetic Pickup Input
53302400 ①	8				8-Digit Backlight Totalizer
53302401 ①	8	•		•	Backlit Add/Subtract (Solid-State Input)
53302402	8	•		•	Backlit Add/Subtract (Contact Input)
53302403	8	•		•	Backlit Quadrature Totalizer
53302405	8	•	4/5	•	Backlit Totalizer, 1/TAU Ratemeter
ac/dc Powered, LED Totalizers					
57700480 ①	6	•	5	•	9 – 30 Vdc, Totalizer, 1/TAU Ratemeter
57700482 ①	6	•	5	•	9 – 30 Vdc, Totalizer, Rate, Analog Out
57700484 ①	6	•	5	•	9 – 30 Vdc, Totalizer, Rate, RS-485
57700486	6	•	5	•	9 – 30 Vdc, Totalizer, Rate, Analog Out, RS-485
57701480 ①	6	•	5	•	85 – 265 Vac, Totalizer, 1/TAU Ratemeter
57701482 ①	6	•	5	•	85 – 265 Vac, Totalizer, Rate, Analog Out
57701484 ①	6	•	5	•	85 – 265 Vac, Totalizer, Rate, RS-485
57701486 ①	6	•	5	•	85 – 265 Vac, Totalizer, Rate, Analog Out, RS-485
ac/dc Powered, 2-Line, LCD Display					
57600400	8	•	6	•	10 – 15 Vdc, LCD Green Display
57601400 ①	8	•	6	•	115 Vac, LCD Green Display
57602400	8	•	6	•	230 Vac, LCD Green Display
Traditional Full Featured, ac/dc-Powered, LED Display					
58810400 ①	8			•	115/230 Vac, LED Red Display
58811400 ①	8	•		•	115/230 Vac, LED Red Display
58815400 ①	8	•	8	•	115/230 Vac, LED Red Display, 1/TAU Ratemeter
Basic Pulse Count, LED Display					
57810400 ①	7			•	115 Vac, LED Red Display

① Items will normally ship within one week.

Totalizers — Mechanical and Electromechanical

Mechanical Totalizers



X Series Stroke

Light Duty Stroke and Revolution Counters

- 1/8" diameter stainless steel shaft
- Plastic frame and cover
- 4 or 5 digits
- 1000 CPM
- Overall size 3.06" x 1.44" x 1.38"



D Series Revolution

Medium Duty Stroke and Revolution Counters

- 5/16" diameter stainless steel shaft
- Metal frame and metal cover
- 4, 5 or 6 digits
- 400 CPM (stroke), 1500 CPM (D6 Rev), 800 CPM (D7 Rev)
- Overall size 3.69" x 3.63" x 2.00"



H Series Revolution

Heavy Duty Stroke and Revolution Counters

- 5/16" diameter stainless steel shaft
- Plastic frame and metal cover
- 5 digits
- 800 CPM
- Overall size 7.27" x 2.25" x 2.77"

Electromechanical Totalizers



SE Series

Subminiature Electric

- 6-digit non-reset
- Various mounting configurations
- ac or dc voltages
- 600 CPM
- Overall size 1.31" x 1.00" x 2.16"



RMF Series

Heavy Duty Industrial

- 6- and 7-digit resettable
- Various mounting configurations
- ac or dc voltages
- 3 different count speeds available:
 - MF 750 CPM
 - RMF 1000 CPM
 - YE 1800 – 2400 CPM
- Overall size 3.69" x 1.25" x 2.56"



ME Series

Miniature Electric

- 4- or 6-digit resettable, 6- or 7-digit non-resettable
- Various mounting configurations based on numbers of digits
- ac or dc voltages
- 1000 CPM
- Overall size 2.25" x 2.45" x 1.80"

Totalizers — Mechanical and Electromechanical (continued)

MECHANICAL TOTALIZERS SELECTION CHART

Catalog Number	Order Number	Digits	Stroke Direction	Shaft Extension	Rotation	Ratio	Reset
X Series Stroke							
4-X-1-1-R	40263401 1	4	Forward	Right		1:1	Knob
4-X-1-1-L	40263400	4	Forward	Left		1:1	Knob
4-X-1-1-R-REV	40263402	4	Reverse	Right		1:1	Knob
5-X-1-1-R	40272402 1	5	Forward	Right		1:1	Knob
5-X-1-1-L	40272401 1	5	Forward	Left		1:1	Knob
5-X-1-1-R-REV	40272403 1	5	Reverse	Right		1:1	Knob
4-X-2	21619400 1	4	Forward	NA		1:1	Knob
4-X-2-A	33245400 1	4	Forward	NA		1:1	Knob
X Series Revolution							
4-X-7-1-R-CL 1:1	40270407 1	4		Right	CL	1:1	Knob
4-X-7-1-R-CL 10:1	40270403	4		Right	CL	10:1	Knob
4-X-7-1-R-AC 1:1	40270405 1	4		Right	AC	1:1	Knob
4-X-7-1-R-AC 10:1	40270401 1	4		Right	AC	10:1	Knob
4-X-7-1-L-CL 1:1	40270406	4		Left	CL	1:1	Knob
4-X-7-1-L-CL 10:1	40270402 1	4		Left	CL	10:1	Knob
5-X-7-1-R-CL 10:1	40275403	5		Right	CL	10:1	Knob
5-X-7-1-R-AC 10:1	40275401 1	5		Right	AC	10:1	Knob
D Series Stroke							
4-D-1-1-R	34269401 1	4	Forward	Right		1:1	Knob
5-D-1-1-R	34269402 1	5	Forward	Right		1:1	Knob
5-D-1-1-L	34269406 1	5	Forward	Left		1:1	Knob
6-D-1-1-R	34269403 1	6	Forward	Right		1:1	Knob
D Series Revolution							
5-D-6-1-CL	31052404 1	5		Front/Rear	CL	1:1	Knob
5-D-6-1-AC	31052401 1	5		Front/Rear	AC	1:1	Knob
5-D-7-1-R-CL	31127431 1	5		Right	CL	1:1	Knob
5-D-7-1-R-AC	31127400 1	5		Right	AC	1:1	Knob
5-D-7-1-L-CL	31127408 1	5		Left	CL	1:1	Knob
5-D-7-1-L-AC	31127405 1	5		Left	AC	1:1	Knob
5-D-7-3-R-CL	31127438	5		Right	CL	1:1	None
5-D-7-3-L-AC	31127412	5		Left	AC	1:1	None
H Series Stroke							
5-H-1-1-R	40205400 1	5	Forward	Right		1:1	Knob
5-H-1-1-R-RP	40205404 1	5	Forward	Right		1:1	Knob
5-H-1-1-R-REV	00597400	5	Reverse	Right		1:1	Knob
5-H-1-1-L	40205401 1	5	Forward	Left		1:1	Knob
5-H-1-2-R	40206404 1	5	Forward	Right		1:1	Key
5-H-1-2-R-RP	40206400	5	Forward	Right		1:1	Key
5-H-1-2-L	40206405	5	Forward	Left		1:1	Key
H Series Revolution							
5-H-7-1-R-CL	00513400 1	5		Right	CL	1:1	Knob
5-H-7-1-R-AC	00514400 1	5		Right	AC	1:1	Knob
5-H-7-1-L-CL	00509400	5		Left	CL	1:1	Knob
5-H-7-1-L-AC	00510400 1	5		Left	AC	1:1	Knob

1 Items will normally ship within one week.

All totalizers listed are base mounted.

All forward reverse actions are stroke counters. All revolution totalizers are either CL (clockwise) rotation or AC (anti-clockwise) rotation.

All revolution totalizers count down when shaft rotation is reversed.

Ratio is the number of counts per revolution of shaft or actuation of stroke arm.

H Series Stroke "RP" units intended for humid (condensing) environments.

ELECTROMECHANICAL TOTALIZERS SELECTION CHART

Catalog Number	Order Number	Digits	Voltage*	Mounting	Reset
SE Series					
6-Y-41610-4XX-SE	416104XX	6	•	Bottom	None
6-Y-41611-4XX-SE	416114XX	6	•	Base	None
6-Y-41612-4XX-SE	416124XX	6	•	Top	None
6-Y-41613-4XX-SE	416134XX	6	•	Panel	None
6-Y-42613-4XX-SE	426134XX	6	•	Snap In	None
6-Y-41623-4XX-SE	416234XX	6	•	Special Top	None
6-Y-41622-4XX-SE	416224XX	6	•	Special Base	None
RMF Series					
6-Y-1-RMF-24A	31155400	6	24 Vac	Base	Knob
6-Y-1-RMF-115A	31155402 ①	6	115 Vac	Base	Knob
6-Y-1-RMF-PM-115A	31066416 ①	6	115 Vac	Panel	Knob
6-Y-1-RMF-230A	31155401	6	230 Vac	Base	Knob
6-Y-1-RMF-PM-230A	31066413	6	230 Vac	Panel	Knob
6-Y-12-RMF-PM-115A	31083403 ①	6	115 Vac	Panel	Key Lock
6-Y-13-RMF-115A	31039400	6	115 Vac	Base	None
6-Y-13-RMF-PM-115A	31155405 ①	6	115 Vac	Panel	None
7-Y-1-RMF-115A	31025400	7	115 Vac	Base	Knob
7-Y-1-RMF-PM-115A	31026401 ①	7	115 Vac	Panel	Knob
7-Y-12-RMF-PM-115A	31083409 ①	7	115 Vac	Panel	Key Lock
7-Y-13-RMF-115A	31026400	7	115 Vac	Base	None
7-Y-13-RMF-PM-24D	33183400 ①	7	24 Vdc	Panel	None
7-Y-13-RMF-PM-115A	31026402 ①	7	115 Vac	Panel	None
MF Series					
6-Y-1-MF-120A	32651400 ①	6	120 Vac	Base	Knob
6-Y-1-MF-PM-120A	32653400 ①	6	120 Vac	Panel	Knob
6-Y-12-MF-PM-120A	32654400 ①	6	120 Vac	Panel	Key Lock
6-Y-13-MF-120A	32658400	6	120 Vac	Base	None
7-Y-1-MF-120A	32650400	7	120 Vac	Base	Knob
7-Y-12-MF-PM-120A	32655400	7	120 Vac	Panel	Key Lock
YE Series					
6-YE-40724-400-ER	40724400 ①	6	120 Vac	Panel	Electric
6-YE-40724-401-Q	40724401 ①	6	120 Vac	Panel	Pushbutton
6-YE-40724-404-ER	40724404	6	24 Vdc	Panel	Electric
6-YE-40724-410-Q	40724410	6	28 Vdc	Panel	Pushbutton
6-YE-40724-412-Q	40724412	6	24 Vdc	Panel	Pushbutton
6-YE-40724-413-ER	40724413	6	28 Vdc	Panel	Electric
6-YE-40725-400-ER	40725400	6	120 Vac	Base	Electric
6-YE-40725-401-Q	40725401	6	120 Vac	Base	Pushbutton
6-YE-40990-400-NR	40990400	6	120 Vac	Panel	None
ME Series					
4-Y-41312-4XX-MEQ	413124XX	4	•	Bottom	Pushbutton
4-Y-41313-4XX-MEQ	413134XX	4	•	Base	Pushbutton
4-Y-41314-4XX-MEQ	413144XX	4	•	Panel	Pushbutton
6-Y-41321-4XX-MEQ	413214XX	6	•	Bottom	Pushbutton
6-Y-41322-4XX-MEQ	413224XX	6	•	Base	Pushbutton
6-Y-41323-4XX-MEQ	413234XX	6	•	Panel	Pushbutton
6-Y-41119-4XX-ME	411194XX	6	•	Bottom	None
6-Y-41345-4XX-ME	413454XX	6	•	Base	None
6-Y-41346-4XX-ME	413464XX	6	•	Panel	None
7-Y-41238-4XX-ME	412384XX	7	•	Bottom	None
7-Y-41337-4XX-ME	413374XX	7	•	Base	None
7-Y-41349-4XX-ME	413494XX	7	•	Panel	None

① Items will normally ship within one week.

Voltage Key for SE and ME Series

• Voltage	Order No.
24 Vdc	402
120 Vac	406
240 Vac	407

Count Controls — Electronic

Count Controls are counters that provide output signal(s) at preset count value(s). Typical applications include cut-to-length, batching, filling, mixing and dispensing.

Available from Durant are a variety of count controls in different sizes, display types and feature sets.



E4148790

Battery Powered, 2-Line LCD

- 6-digit, LCD display
- 8.5 mm (0.34") high digits
- 1 preset
- Output:
 - SPST 8 A 260 Vac
 - 2 A 30 Vdc
- Removable screw terminals
- 2 replaceable 1/2AA 3 V lithium batteries
- Battery included
- NEMA 4/IP65
- CE marked



E4148793

ac/dc Powered, 2-Line LCD

- 6-digit, LCD display
- 8.5 mm (0.34") high digits
- 1 preset
- Output:
 - SPDT 5 A 250 Vac
 - 2 A 30 Vdc
- 12 Vdc, 100 mA
- Removable screw terminals
- 94 – 240 Vac, 12 – 24 Vdc input power
- NEMA 4/IP65
- UL, cUL recognized
- CE marked



E4148794

ac/dc Powered, 2-Line LCD

- 6-digit, LCD display
- 8.5 mm (0.34") high digits
- 2 preset or 1 preset w/batch
- Output:
 - SPST 5 A 250 Vac
 - 2 A 30 Vdc
- 12 Vdc, 100 mA
- Removable screw terminals
- 94 – 240 Vac, 12 – 24 Vdc input power
- NEMA 4/IP65
- UL, cUL recognized
- CE marked

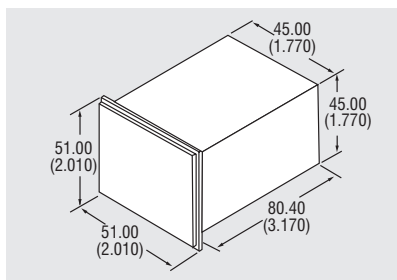

Panel Cutout: 45 x 45 (1.77 x 1.77)
Approximate in mm (inches).

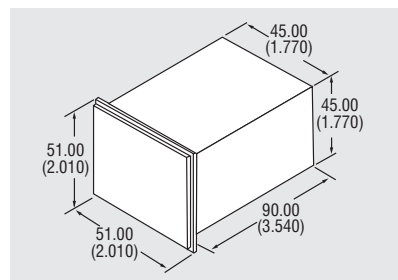

Panel Cutout: 45 x 45 (1.77 x 1.77)
Approximate in mm (inches).

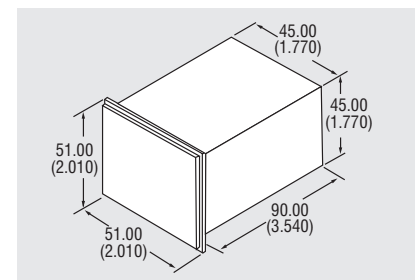

Panel Cutout: 45 x 45 (1.77 x 1.77)
Approximate in mm (inches).



57701481

ac/dc Powered, LED Count Control

- 6-digit, LED display, 14 mm (0.56") high characters
- Available presets:
 - 2 presets
 - Presettable batch counter
- 2 Form C relays
- 12 Vdc, 75 mA maximum
- Removable screw terminals
- Power input 85 – 265 Vac; 9 – 30 Vdc models available
- Optional analog output
- Optional RS-485 communications
- NEMA 4X front panel
- UL, cUL listed
- CE marked
- For configuration software, see ProFile, [Page 37](#)

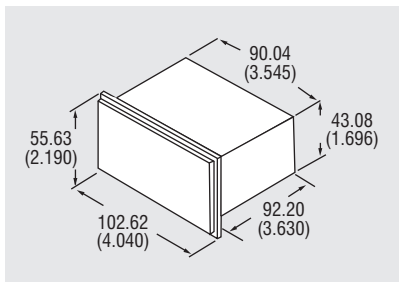

Panel Cutout: 45 x 92 (1.772 x 3.622)
Approximate in mm (inches).



58831400

ac/dc Powered, LED Display

- 5- or 6-digit, LED display, 14 mm (0.56") high digits
- 1, 2 or 3 presets
- 2 Form C relays
- 15 Vdc, 100 mA maximum power output
- Count and rate scalers
- Tactile keypad
- 20 mA current loop communications
- 115/230 Vac, 11 – 28 Vdc input power
- NEMA 4 front panel
- UL, cUL listed
- CE marked

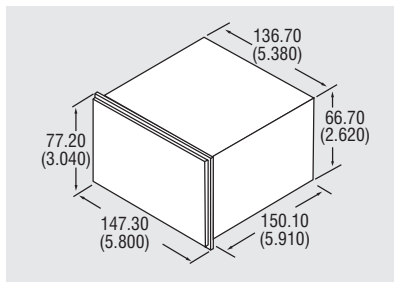

Panel Cutout: 138 x 68 (5.433 x 2.677)
Approximate in mm (inches).



57601401

ac/dc Powered, 2-Line LCD Display

- 6-digit high visibility 7.5 mm (0.3") high characters
- 1, 2 or 4 presets
- 1 or 2 Form C relays
- 12 Vdc, 100 mA maximum output power
- 115 or 230 Vac or 10 – 15 Vdc input power
- RS-485 communications included
- Removable screw terminals
- 4 programmable control inputs
- Program lockout feature
- NEMA 4X front panel
- UL, cUL listed
- CE marked
- For configuration software, see ProFile, [Page 37](#)

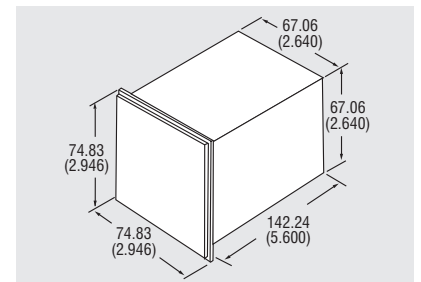

Panel Cutout: 68 x 68 (2.677 x 2.677)
Approximate in mm (inches).

Count Controls — Electronic

(continued)

ELECTRONIC COUNT CONTROLS SELECTION CHART

Order Number	Totalizer	Batch Counter	Main Presets	Rate	Crop Cut	Digits	Display Color	Relays Transistors	Analog Output	Description
Electronic 2-Line LCD Display										
E4148790			1			6	G	1/0		Single Preset Battery Powered
E4148793			1			6	G	1/0		Single Preset Counter
E4148794		•	2			6	G	1/0		Dual Preset or Single Preset with Batch
ac/dc Powered, LED Display										
57700481	•	•	2	•	•	6	R	2/0		9 – 30 Vdc Powered
57700483	•	•	2	•	•	6	R	2/0	•	9 – 30 Vdc Powered
57700485	•	•	2	•	•	6	R	2/0		9 – 30 Vdc Powered, RS-485
57700487	•	•	2	•	•	6	R	2/0	•	9 – 30 Vdc Powered, RS-485
57701481	•	•	2	•	•	6	R	2/0		85 – 265 Vac Powered
57701483	•	•	2	•	•	6	R	2/0	•	85 – 265 Vac Powered
57701485	•	•	2	•	•	6	R	2/0		85 – 265 Vac Powered, RS-485
57701487	•	•	2	•	•	6	R	2/0	•	85 – 265 Vac Powered, RS-485
ac/dc Powered, LED Display										
57820400			1	•		5	R	1/1		115 Vac No Comm. Rate Control Mode Available
58821400			1			5	R	1/1		Single Preset with Scaling
58825400			1	•		5	R	1/1		Single Preset with Scaling and Rate
58831400			2			5	R	2/2		Dual Preset with Scaling
58841400		•	2		•	6	R	2/5		Dual Preset with Batch
58851400	x	x	2		•	6	R	2/5		May Have Preset Batch Counter or Totalizer Counter
58861400			3			6	R	2/5		Preset 1 & 2 May be Used as Floating Prewarn
58827400	>	>	1 ea	•		6	R	2/5		Main Counter, Batch & Totalizer Presets
58827410	<>	<>	1 ea	•		6	R	2/5		2 Independent Count Registers
58867400		•	2	•	•	6	R	2/5		High Speed Count Control — 30 kHz Max.
ac/dc Powered, 2-Line LCD Display										
57601401			1	•	•	6	G	1/2		Single Preset with Rate, 115 Vac
57601402	•	•	1	•	•	6/8	G	1/2		Single Preset with Rate Batch & Totalizer, 115 Vac
57601403			2	•	•	6	G	2/2		Dual Preset with Rate, 115 Vac
57601404	•	•	2	•	•	6/8	G	2/2		Dual Preset with Rate, Batch & Totalizer, 115 Vac
57600405	•	•	4	•	•	6/8	G	2/2		Four Preset with Rate, Batch & Totalizer, 10 – 15 Vdc
57601405	•	•	4	•	•	6/8	G	2/2		Four Preset with Rate, Batch & Totalizer, 115 Vac
57602405	•	•	4	•	•	6/8	G	2/2		Four Preset with Rate, Batch & Totalizer, 230 Vac

Items will normally ship within one week.

G = Green; R = Red

x = These models have, in addition to the main count register, a register that may be configured to be used as either a totalizer or single preset batch counter. These two functions are mutually exclusive.

> = Model has both a totalizer and a batch counter each with a single preset. In addition, the batch counter may be configured as an additional totalizer with control instead of batch counter.

<> = Model has two completely independent count input channels feeding two, independent, single preset count registers. In addition, a third single preset register may be used as either a totalizer or a batch counter for one or both of the two main counters.

Count Controls — Electromechanical



5-Y-41433-406-PD-Q

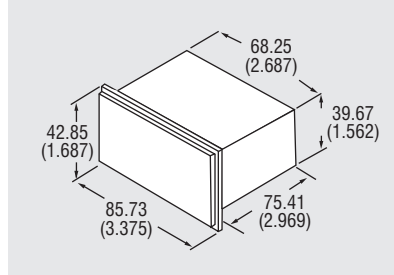

Panel Cutout: 69.04 x 40.46 (2.718 x 1.593)
Approximate in mm (inches).

Predetermined Counters

- 5-digit
- Various mounting configurations
- ac or dc voltages
- 1000 CPM

ELECTROMECHANICAL COUNT CONTROLS SELECTION CHART

Catalog Number	Order Number	Digits	Voltage	Mounting	Reset	UL
5-Y-41433-402-PD-Q	41433402	5	24 Vdc	Panel	Pushbutton	•
5-Y-41433-406-PD-Q	41433406	5	120 Vac	Panel	Pushbutton	•
5-Y-41433-407-PD-Q	41433407	5	240 Vac	Panel	Pushbutton	
5-Y-41469-402-PD-Q	41469402	5	24 Vdc	Base	Pushbutton	•
5-Y-41469-406-PD-Q	41469406	5	120 Vac	Base	Pushbutton	•
5-Y-41469-407-PD-Q	41469407	5	240 Vac	Base	Pushbutton	
5-Y-41470-402-PD-Q	41470402	5	24 Vdc	Base	Pushbutton	•
5-Y-41470-406-PD-Q	41470406	5	120 Vac	Base	Pushbutton	•
5-Y-41470-407-PD-Q	41470407	5	240 Vac	Base	Pushbutton	
5-Y-41625-402-PD-ER	41625402	5	24 Vdc	Panel	Electric	•
5-Y-41625-406-PR-ER	41625406	5	120 Vac	Panel	Electric	•
5-Y-41625-407-PD-ER	41625407	5	240 Vac	Panel	Electric	

Items will normally ship within one week.

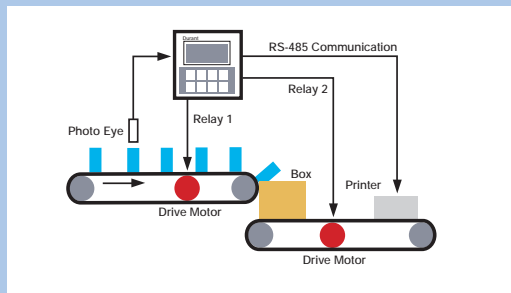

Parts Counting with Printer Output

With a 57601405, you can count parts fed into a box; stop the parts when the box is full; move the full box down line; automatically print job information for labeling the box, and then begin the process all over again.

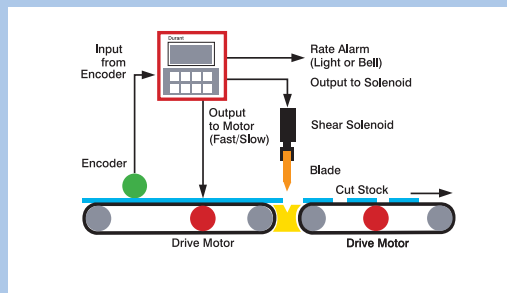

Cut to Length Applications

The 57601405 can be used in a traditional high speed/low speed cut to length application by using presets 1 and 2 for the slowdown signal and the cut signal. Preset 3 can be used as a rate alarm output to signal if the process has been stopped, or if the infeed stock runs out.

Ratemeters

Ratemeters are used in a variety of applications where it is necessary to monitor the speed of a process. Conveyors, baking ovens, material flow and motor speed are typical uses for

ratemeters. Durant models with alarm outputs can be used to detect high or low rates. Rate indicators are often included as a standard feature on totalizers and count controls.



53300404

1/TAU, Battery Powered, LCD Display

- 4-digit, LCD display, 10.8 mm (0.43") high characters
- 10 kHz rate input speed
- Programmable decimal point
- 0.001 – 9999 scaling range
- Lithium battery, 5-year typical life, user replaceable
- Battery included
- Rear-panel screw terminal
- Optional backlight
- NEMA 4X front panel
- CE marked



57701470

1/TAU, LED Display

- 5-digit, LED display, 14 mm (0.56") high digits
- 10 kHz maximum input frequency
- Programmable decimal point
- 0.001 – 9999 scaling range
- Programmable average and zero times
- 12 Vdc, 75 mA maximum output power
- Removable screw terminals
- 85 – 265 Vac or 9 – 30 Vdc input power
- Available options, relay out, analog out, RS-485 options
- NEMA 4X front panel
- UL, cUL listed
- CE marked
- For configuration software, see ProFile, **Page 37**



57151405

1/TAU, 2-Line LCD Display

- 2-line, 5-digit high visibility, 7.5 mm (0.3") characters, backlight display
- 1 or 2 rate inputs
- 2 rate alarms
- Dual rate unit ratio calculations — A/B, A-B or draw
- Programmable average and zero times
- Programmable decimal point
- 12 Vdc, 100 mA maximum output power
- Removable screw terminals
- 115 or 230 Vac, or 10 – 15 Vdc input power
- RS-485 communications included
- NEMA 4 front panel
- UL, cUL listed
- CE marked
- For configuration software, see ProFile, **Page 37**

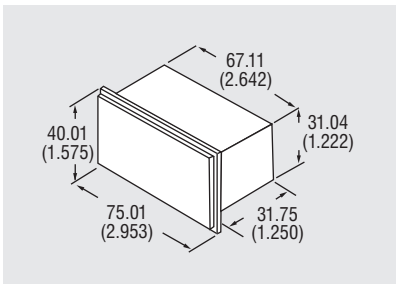

Panel Cutout: 33 x 68 (1.299 x 2.677)
Approximate in mm (inches).

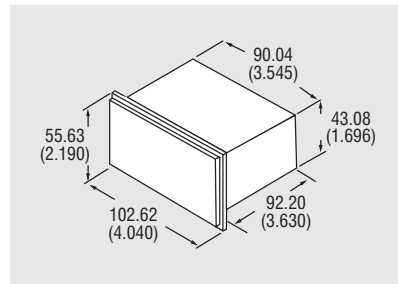

Panel Cutout: 45 x 92 (1.772 x 3.622)
Approximate in mm (inches).

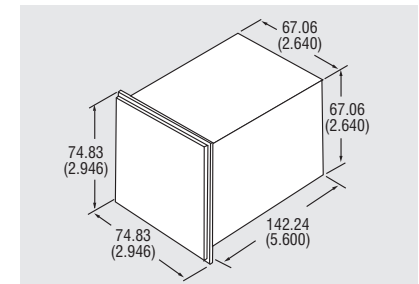

Panel Cutout: 68 x 68 (2.677 x 2.677)
Approximate in mm (inches).

RATEMETER SELECTION CHART

Order Number	Operating Power	Ratemeters	Rate Alarms	Ratio	Ratio Alarms	Analog Output	Description
1/TAU, Battery Powered, LCD Display							
53300404	Battery	1					1/TAU Ratemeter
53300405	Battery	1					Totalizer, 1/TAU Ratemeter
53301404	Battery	1					1/TAU Ratemeter — Extended Temperature Range
53301405	Battery	1					Totalizer, 1/TAU Ratemeter — Extended Temperature Range
53301475	Battery	1					Totalizer/Ratemeter with Magnetic Pickup Input
53302405	Battery	1					Backlit Totalizer, 1/TAU Ratemeter
1/TAU, 2-Line LCD Display							
57150400	10 – 15 Vdc	1	2				Single Input Rate Indicator
57151400	115 Vac	1	2				Single Input Rate Indicator
57152400	230 Vac	1	2				Single Input Rate Indicator
57150405	10 – 15 Vdc	2	2	•	2	•	Dual Input Rate/Ratio/Draw with Alarms and Analog Out
57151405	115 Vac	2	2	•	2	•	Dual Input Rate/Ratio/Draw with Alarms and Analog Out
57152405	230 Vac	2	2	•	2	•	Dual Input Rate/Ratio/Draw with Alarms and Analog Out
1/TAU, LED Display							
57700470	9 – 30 Vdc	1					Single Input Rate Indicator
57700471	9 – 30 Vdc	1	2				Single Input, Alarms
57700472	9 – 30 Vdc	1				•	Single Input, Analog Out
57700473	9 – 30 Vdc	1	2			•	Single Input, Alarms, Analog Out
57700474	9 – 30 Vdc	1					Single Input, RS-485
57700475	9 – 30 Vdc	1	2				Single Input, Alarms, RS-485
57700476	9 – 30 Vdc	1				•	Single Input, Analog Out, RS-485
57700477	9 – 30 Vdc	1	2			•	Single Input, Alarms, Analog Out, RS-485
57701470	85 – 265 Vac	1					Single Input Rate Indicator
57701471	85 – 265 Vac	1	2				Single Input, Alarms
57701472	85 – 265 Vac	1				•	Single Input, Analog Out
57701473	85 – 265 Vac	1	2			•	Single Input, Alarms, Analog Out
57701474	85 – 265 Vac	1					Single Input, RS-485
57701475	85 – 265 Vac	1	2				Single Input, Alarms, RS-485
57701476	85 – 265 Vac	1				•	Single Input, Analog Out, RS-485
57701477	85 – 265 Vac	1	2			•	Single Input, Alarms, Analog Out, RS-485

🕒 Items will normally ship within one week.

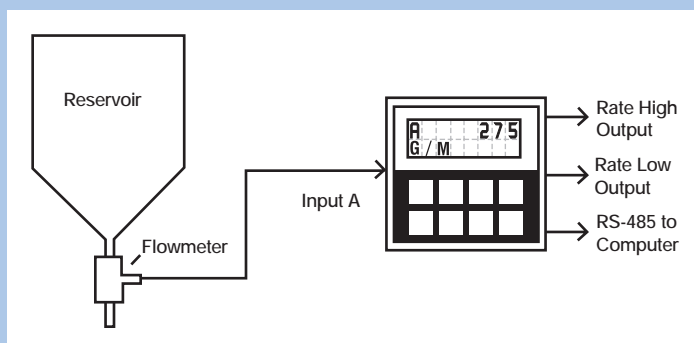

Flow Rate Application

A common ratemeter use is monitoring flow rate. The process may be long term, such as water consumption, steam production, or oil flow in a pipeline, or of short duration such as metering chemicals or additives in a food or chemical process batching application.

The ratemeter accepts NPN or contact closure pulses from ratemeters or sourcing PNP pulses up to 17 Vdc peak. Sourcing pulses above 17 Vdc can be attenuated through a series resistor. Two-wire magnetic flowmeter pulses can be used as a signal source, but typically a 418160400 signal conditioner should be used to interface the magnetic

flowmeter and the ratemeter. Analog outputs are very common from flowmeters, especially 4 – 20 mA, and must be converted to digital by an analog-to-frequency converter such as the Durant 48160451.

The ratemeter scales the frequency of the incoming pulses to units of volume or mass per unit time. The rate is displayed and compared to the programmable alarm setpoints, if used. The alarm output(s) will energize if the rate crosses the setpoint threshold(s).

The RS-485 serial port allows a computer to monitor rate and setpoints. If the computer is running a data acquisition program, it can create rate profiles and record alarm conditions for up to 100 Durant ratemeters.

Timers

Timers are used in applications where time itself is the main focus. These include simple knowledge of how long a machine has been running to determine machine maintenance, for example, (elapsed time) to knowing when to change an elevator cable (cable life and safety). Timers generally have the ability to stop and then to continue on from the point at which they stopped.

Timer Relays are used in applications where an output is required to make something happen at a predetermined point in time (to stop or start the process).



E4148793

ac Powered Electronic Time Control

- Digital
- 6-digit, 8.5 mm (.33") high LCD display
- Single preset timer
- 1 SPDT relay — programmable
- Removable screw terminals
- 1 second to 999,999 hours
- 94 – 240 Vac or 12 – 24 Vdc input power
- 12 Vdc, 100 mA output power
- NEMA 4/IP65
- UL, cUL listed
- CE marked



E42DI2475

Battery Powered Elapsed Timer

- Battery included
- 8-digit, 7 mm (0.28") LCD
- NEMA 4
- Reset can be enabled/disabled
- High voltage enable and high voltage reset adapter available, see **Page 38**



E42DIR

Hour Meter — Round

- ac/dc powered
- 6-digit, 5 mm (0.2") LCD
- NEMA 12
- EEPROM memory



E42DI

Hour Meter — Rectangular

- ac/dc powered
- 6-digit, 5 mm (0.2") LCD
- NEMA 12
- EEPROM memory

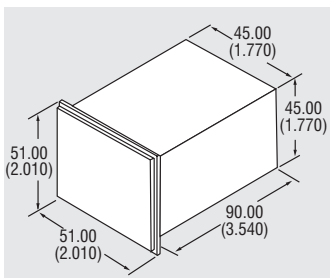

Panel Cutout: 45 x 45 (1.770 x 1.770)
Approximate in mm (inches).

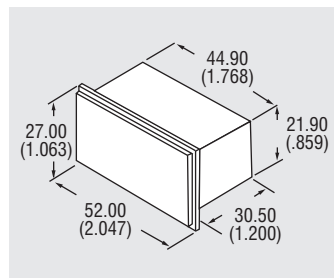

Panel Cutout: 22 x 45 (0.870 x 1.772)
Approximate in mm (inches).

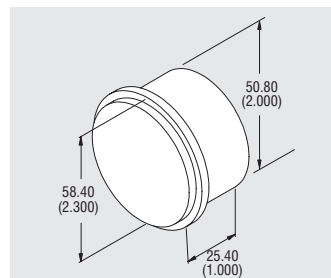

Panel Cutout: 52.3 (2.060)
Approximate in mm (inches).

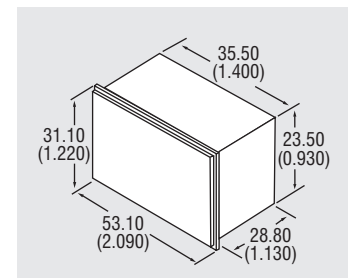

Panel Cutout: 24.1 x 36.8 (0.950 x 1.450)
Approximate in mm (inches).



E42A24M

ac/dc Powered Time Control

- Analog
- 7 timing modes
- Panel mounted
- 0.02 sec. to 300 hours



E42DP55

Battery Powered Time Control

- Battery included
- Digital
- 8 timing modes
- DIN rail mounted
- 0.2 sec. to 999 hours



E42DP50

Battery Powered Time Control

- Battery included
- Digital
- 8 timing modes
- Panel mounted
- 0.2 sec. to 999.99 hours

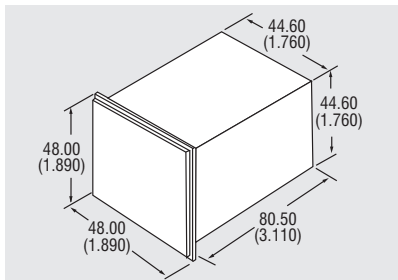

Panel Cutout: 45 x 45 (1.77 x 1.77)
Approximate in mm (inches).

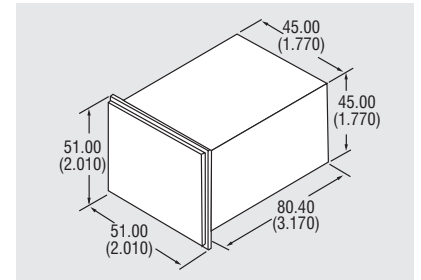
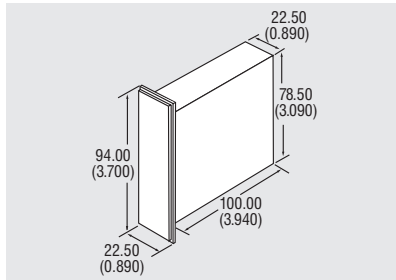

Panel Cutout: 45 x 45 (1.77 x 1.77)
Approximate in mm (inches).

TIMER SELECTION CHART

Order Number	Function	Supply Voltage	Time Range	Control Output	Approvals	NEMA
E4148793 ①	Time Control	94 – 240 Vac / 12 – 24 Vdc	1 sec. – 99,999.9 hours	SPDT Relay	UL, CE, cUL	NEMA 4/IP65
E42A24M	Analog Time Relay	24 – 240 Vac / 12 – 24 Vdc	0.02 sec. – 300 hours	DPDT Relay	UL, CSA, CE	
E42A11 BaseSock	Socket for E42A24M					
E42DP55 ①	Digital Time Relay	Two 3 V Lithium Batteries	0.02 sec. – 999 hours	SPDT Relay	UL, CE, cUL	NEMA 12/IP51
E42DP50 ①	Digital Time Relay	Two 3 V Lithium Batteries	0.2 sec. – 999.99 hours	SPST Relay	CE	NEMA 4/IP65
E42DI2475S ①	Elapsed Timer	Lithium Battery	Minutes/Seconds		UL, CE	NEMA 4/IP65
E42DI2475H ①	Elapsed Timer	Lithium Battery	Hours/Minutes Hours/Hundredths		UL, CE	NEMA 4/IP65
E42DIR48230 ①	Elapsed Timer	48 – 150 Vdc / 100 – 230 Vac	0 – 99,999.9 hours		UL, CE	
E42DIR48230R	Elapsed Timer	48 – 150 Vdc / 100 – 230 Vac	0 – 99,999.9 hours		UL, CE	
E42DIR1260 ①	Elapsed Timer	12 – 48 Vdc / 20 – 60 Vac	0 – 99,999.9 hours		UL, CE	
E42DIR1260R	Elapsed Timer	12 – 48 Vdc / 20 – 60 Vac	0 – 99,999.9 hours		UL, CE	
E42DI2448230 ①	Elapsed Timer	48 – 150 Vdc / 100 – 230 Vac	0 – 99,999.9 hours		UL, CE	
E42DI2448230R	Elapsed Timer	48 – 150 Vdc / 100 – 230 Vac	0 – 99,999.9 hours		UL, CE	
E42DI241260	Elapsed Timer	12 – 48 Vdc / 20 – 60 Vac	0 – 99,999.9 hours		UL, CE	
E42DI241260R	Elapsed Timer	12 – 48 Vdc / 20 – 60 Vac	0 – 99,999.9 hours		UL, CE	

① Items will normally ship within one week.

R indicates resettable.

Digital Panel Meters

Digital Panel Meters are found anywhere a process variable needs to be indicated. Volts, current, pressure, volume, temperature and frequency are typical applications. The product's short depth makes

it flexible and accommodating to panel builder needs. A variety of input and output options allows Durant DPMs to be used virtually anywhere.



57701400

ac/dc Voltage and Amperage Meters and Process Meters

- 4-digit DPM, 1/8 DIN
- Red LED display, 14 mm (0.56") high characters
- dc volts/amps, ac volts/amps, 5 A ac, and process models
- Scalable display
- Maximum/minimum data hold
- Flashing alarms
- Removable screw terminals
- 85 – 265 Vac, 9 – 30 Vdc versions
- Optional analog out
- Optional relays out for alarms
- Optional RS-485 communications
- NEMA 4X front panel
- UL, cUL listed
- CE marked
- For configuration software, see ProFile, Page 37



Current surface mount technology is used to keep production efficiency at its peak.



Microprocessors and memory are programmed for specific models.

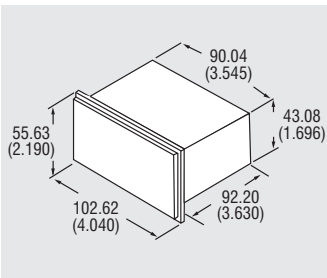

Panel Cutout: 45 x 92 (1.772 x 3.622)
Approximate in mm (inches).

DIGITAL PANEL METERS SELECTION CHART

Order Number*	Function	Range	Alarm Relays	Analog Out	RS-485
5770X400	dc Volts	199.9 mV, 1.999 V, 19.99 V, 199.9 V			
5770X401	dc Volts	199.9 mV, 1.999 V, 19.99 V, 199.9 V	2		
5770X402	dc Volts	199.9 mV, 1.999 V, 19.99 V, 199.9 V		•	
5770X403	dc Volts	199.9 mV, 1.999 V, 19.99 V, 199.9 V	2	•	
5770X404	dc Volts	199.9 mV, 1.999 V, 19.99 V, 199.9 V			•
5770X405	dc Volts	199.9 mV, 1.999 V, 19.99 V, 199.9 V	2		•
5770X406	dc Volts	199.9 mV, 1.999 V, 19.99 V, 199.9 V		•	•
5770X407	dc Volts	199.9 mV, 1.999 V, 19.99 V, 199.9 V	2	•	•
5770X410	ac Volts	199.9 mV, 1.999 V, 19.99 V, 199.9 V			
5770X411	ac Volts	199.9 mV, 1.999 V, 19.99 V, 199.9 V	2		
5770X412	ac Volts	199.9 mV, 1.999 V, 19.99 V, 199.9 V		•	
5770X413	ac Volts	199.9 mV, 1.999 V, 19.99 V, 199.9 V	2	•	
5770X414	ac Volts	199.9 mV, 1.999 V, 19.99 V, 199.9 V			•
5770X415	ac Volts	199.9 mV, 1.999 V, 19.99 V, 199.9 V	2		•
5770X416	ac Volts	199.9 mV, 1.999 V, 19.99 V, 199.9 V		•	•
5770X417	ac Volts	199.9 mV, 1.999 V, 19.99 V, 199.9 V	2	•	•
5770X420	dc Amps	199.9 uA, 1.999 mA, 19.99 mA, 199.9 mA			
5770X421	dc Amps	199.9 uA, 1.999 mA, 19.99 mA, 199.9 mA	2		
5770X422	dc Amps	199.9 uA, 1.999 mA, 19.99 mA, 199.9 mA		•	
5770X423	dc Amps	199.9 uA, 1.999 mA, 19.99 mA, 199.9 mA	2	•	
5770X424	dc Amps	199.9 uA, 1.999 mA, 19.99 mA, 199.9 mA			•
5770X425	dc Amps	199.9 uA, 1.999 mA, 19.99 mA, 199.9 mA	2		•
5770X426	dc Amps	199.9 uA, 1.999 mA, 19.99 mA, 199.9 mA		•	•
5770X427	dc Amps	199.9 uA, 1.999 mA, 19.99 mA, 199.9 mA	2	•	•
5770X430	ac Amps	199.9 uA, 1.999 mA, 19.99 mA, 199.9 mA			
5770X431	ac Amps	199.9 uA, 1.999 mA, 19.99 mA, 199.9 mA	2		
5770X432	ac Amps	199.9 uA, 1.999 mA, 19.99 mA, 199.9 mA		•	
5770X433	ac Amps	199.9 uA, 1.999 mA, 19.99 mA, 199.9 mA	2	•	
5770X434	ac Amps	199.9 uA, 1.999 mA, 19.99 mA, 199.9 mA			•
5770X435	ac Amps	199.9 uA, 1.999 mA, 19.99 mA, 199.9 mA	2		•
5770X436	ac Amps	199.9 uA, 1.999 mA, 19.99 mA, 199.9 mA		•	•
5770X437	ac Amps	199.9 uA, 1.999 mA, 19.99 mA, 199.9 mA	2	•	•
5770X440	5 A ac	5 A			
5770X441	5 A ac	5 A	2		
5770X442	5 A ac	5 A		•	
5770X443	5 A ac	5 A	2	•	
5770X444	5 A ac	5 A			•
5770X445	5 A ac	5 A	2		•
5770X446	5 A ac	5 A		•	•
5770X447	5 A ac	5 A	2	•	•
5770X450	Process	4 – 20 mA, 0 – 10 V, 1 – 5 V			
5770X451	Process	4 – 20 mA, 0 – 10 V, 1 – 5 V	2		
5770X452	Process	4 – 20 mA, 0 – 10 V, 1 – 5 V		•	
5770X453	Process	4 – 20 mA, 0 – 10 V, 1 – 5 V	2	•	
5770X454	Process	4 – 20 mA, 0 – 10 V, 1 – 5 V			•
5770X455	Process	4 – 20 mA, 0 – 10 V, 1 – 5 V	2		•
5770X456	Process	4 – 20 mA, 0 – 10 V, 1 – 5 V		•	•
5770X457	Process	4 – 20 mA, 0 – 10 V, 1 – 5 V	2	•	•

Input Power
9 – 30 Vdc for 577004XX
85 – 265 Vac for 577014XX

Flow Totalizers/Transmitters and Controls

Flow products are used in a variety of applications where liquid or gas flow needs to be monitored or controlled. Durant offers models

for flow total, flow rate, and flow batch control. Several optional outputs allow great flexibility to meet most application needs.



57751400

Totalizer/Ratemeter

- 6-digit or 10-digit LED display, 14 mm (0.56") high characters
- 6-digit ratemeter with low/high set points
- Analog or pulse input versions
- Separate rate and total scale factors
- 15-point linearization in analog models
- Square root extraction in analog models
- Analog input models accept 4 – 20 mA or 0 – 10 V
- Pulse input version accepts magnetic or transistor input
- 12 Vdc output on pulse models
- 85 – 265 Vac universal power supply
- 9 – 30 Vdc models available
- NEMA 4X front panel
- UL, cUL listed
- CE marked
- For configuration software, see ProFile, **Page 37**



57751411

Batch Control

- 6-digit LED display, 14 mm (0.56") high characters
- 6-digit ratemeter with high/low set points
- Count and rate scaling
- 15-point linearization or square root extraction in analog models
- Dual valve prewarn operation
- Analog input models accept 4 – 20 mA or 0 – 10 V
- Pulse input version accepts magnetic or transistor input
- 12 Vdc output on pulse models
- 85 – 265 Vac universal power supply
- 9 – 30 Vdc models available
- NEMA 4X front panel
- UL, cUL listed
- CE marked
- For configuration software, see ProFile, **Page 37**



53300405

Battery Powered Total/Rate

- 8-digit LCD display, 10.8 mm (0.43") high characters
- 4- or 5-digit flow rate
- Count and rate scaling
- Rear terminal remote reset
- Front panel reset disable
- Replaceable 5-year battery
- Battery included
- Magnetic flowmeter input model
- Backlit model
- Extended temperature range models available
- CE marked

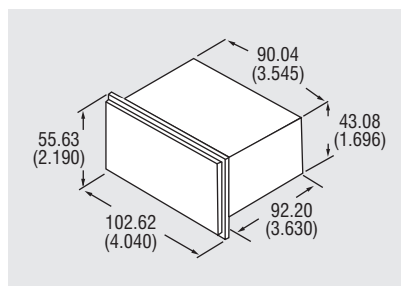

Panel Cutout: 45 x 92 mm (1.770 x 3.620)
Approximate in mm (inches).

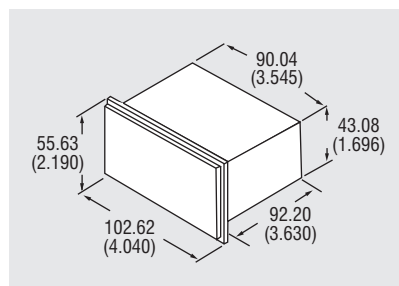

Panel Cutout: 45 x 92 mm (1.770 x 3.620)
Approximate in mm (inches).

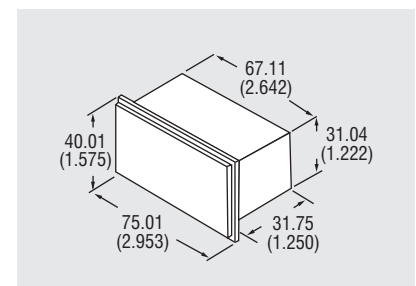

Panel Cutout: 33 x 68 mm (1.299 x 2.677)
Approximate in mm (inches)

FLOW PRODUCTS SELECTION CHART



57625400

OEM Custom Control

- 16-character alphanumeric vacuum fluorescent display, 0.20" high characters
- 2 relay, 5 transistor and 4 – 20 mA outputs
- Accepts digital or analog inputs
- Base model totalizer, batch control, and mass flow computer will be customized for the OEM
- Custom front label includes OEM name and/or logo
- Other count/rate based OEM applications are welcomed
- Depluggable rear terminals
- 24 Vdc, 100 mA maximum output power
- Accepts 120/240 Vac input power
- NEMA 4X front panel
- CSA listed

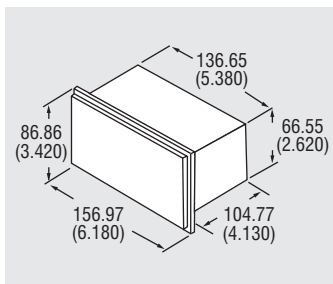

Order Number	Total/Rate	Batch Control	Dual Relays	Relay/Transistor	Analog Out	RS-485	Input Signal
Totalizer/Ratemeter							
5775X400	•						Pulse
5775X401	•		•				Pulse
5775X402	•				•		Pulse
5775X403	•		•		•		Pulse
5775X404	•					•	Pulse
5775X405	•		•			•	Pulse
5775X406	•				•	•	Pulse
5775X407	•		•		•	•	Pulse
5775X40A	•			•			Pulse
5775X40B	•			•	•		Pulse
5775X40C	•			•		•	Pulse
5775X40D	•			•	•	•	Pulse
5775X420	•						Analog
5775X421	•		•				Analog
5775X422	•				•		Analog
5775X423	•		•		•		Analog
5775X424	•					•	Analog
5775X425	•		•			•	Analog
5775X426	•				•	•	Analog
5775X427	•		•		•	•	Analog
5775X42A	•			•			Analog
5775X42B	•			•	•		Analog
5775X42C	•			•		•	Analog
5775X42D	•			•	•	•	Analog
Batch Control							
5775X411	•	•	•				Pulse
5775X413	•	•	•		•		Pulse
5775X415	•	•	•			•	Pulse
5775X417	•	•	•		•	•	Pulse
5775X41A	•	•		•			Pulse
5775X41B	•	•		•	•		Pulse
5775X41C	•	•		•		•	Pulse
5775X41D	•	•		•	•	•	Pulse
5775X431	•	•	•				Analog
5775X433	•	•	•		•		Analog
5775X435	•	•	•			•	Analog
5775X437	•	•	•		•	•	Analog
5775X43A	•	•		•			Analog
5775X43B	•	•		•	•		Analog
5775X43C	•	•		•		•	Analog
5775X43D	•	•		•	•	•	Analog
• Input Power 9 – 30 Vdc for 577504XX 85 – 265 Vac for 577514XX							
Battery Powered Total/Rate							
Order Number	Description						
53300405	Solid-State/Contact Input						
53301405	Extended Temp Solid-State/Contact Input						
53301475	Extended Temp Magnetic Pickup						
53302405	Backlit Solid-State/Contact Input						
OEM Custom Control Base Models							
Order Number	Description						
57625400	Batch Control						
57630400	Totalizer/Ratemeter						
57635400	Mass Flow Computer						

• Items will normally ship within one week.

Temperature Controls/Indicators

Durant offers a variety of temperature controls that use fuzzy logic and PID control that can be used in many applications where temperature must be controlled. These applications include heat

treating, baking, packaging, furnace control, and chillers. Durant also offers a series of temperature indicators with an alarm option for processes that require the temperature to be monitored.



E4524

Temperature Control

- 1/32 DIN
- Full 4-digit LED display, 10 mm (0.4")
- Universal inputs:
 - J, K, T, E, B, R, S, N thermocouples
 - PT100 ohm (DIN or JIS) RTD
 - Linear 4 – 20 mA or 0 – 20 mA
 - Linear 0 – 1, 0 – 5, 1 – 5 or 0 – 10 V
- Universal power supply:
 - 90 – 240 Vac
- Control output:
 - 3 A 240 Vac relay
 - SSR driver
 - Linear 4 – 20 mA, 0 – 20 mA
- Alarm: 3 A 240 Vac SPST relay
- NEMA 4/IP65
- UL listed
- CE marked



E4548

Temperature Control

- 1/16 DIN
- Full 4-digit LED display, 10 mm (0.4")
- Inputs:
 - Thermocouples
 - RTD
 - Linear
- Universal power supply:
 - 90 – 240 Vac
- Control output:
 - 3 A 240 Vac relay
 - SSR driver
 - Linear 4 – 20 mA, 0 – 20 mA
- Alarm: 3 A 240 Vac SPDT relay
- NEMA 12/IP51
- UL listed
- CE marked



57701460

Temperature Indicator

- 1/8 DIN
- 4-digit LED display, 14 mm (0.56")
- Inputs:
 - J, K, T thermocouples
 - 4-wire PT100 RTD (IEC 751)
- Universal power supply:
 - 85 – 265 Vac
- 9 – 30 Vdc models available
- Optional outputs:
 - Dual relays
 - Analog 4 – 20 mA and 0 – 10 V
 - RS-485
 - Combinations
- NEMA 4/IP65
- UL, cUL listed
- CE marked
- For configuration software, see ProFile, [Page 37](#)

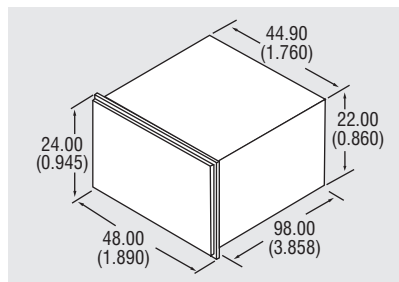

Panel Cutout: 22.2 x 45 (0.874 x 1.770)
Approximate in mm (inches).

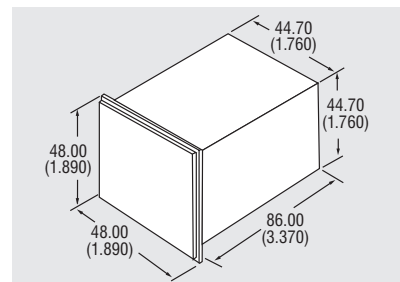

Panel Cutout: 45 x 45 (1.77 x 1.77)
Approximate in mm (inches).

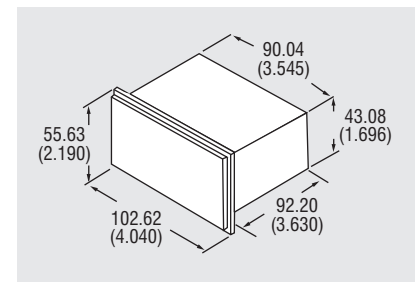

Panel Cutout: 45 x 92 (1.772 x 3.622)
Approximate in mm (inches).

Our prototype department provides quick manufacture of prototypes to keep from interrupting production.



TEMPERATURE CONTROL/INDICATOR SELECTION CHART

Order Number*	Size	Input	Control Output	Alarms/Outputs
Temperature Control 1/32 DIN				
E45241010 ①	1/32 DIN	Universal	Relay	1 Relay
E45242010 ①	1/32 DIN	Universal	SSR Driver	1 Relay
E45243010 ①	1/32 DIN	Universal	4 – 20 mA	1 Relay
Temperature Control 1/16 DIN				
E45481010 ①	1/16 DIN	Thermocouple	Relay	1 Relay
E45482010 ①	1/16 DIN	Thermocouple	SSR Driver	1 Relay
E45483010 ①	1/16 DIN	Thermocouple	4 – 20 mA	1 Relay
E45481010R ①	1/16 DIN	RTD	Relay	1 Relay
E45482010R	1/16 DIN	RTD	SSR Driver	1 Relay
E45483010R	1/16 DIN	RTD	4 – 20 mA	1 Relay
Temperature Indicator				
5770X460	1/8 DIN	J,K,T & 4-wire RTD	N/A	None
5770X461	1/8 DIN	J,K,T & 4-wire RTD	N/A	2 Relays
5770X462	1/8 DIN	J,K,T & 4-wire RTD	N/A	Analog
5770X463	1/8 DIN	J,K,T & 4-wire RTD	N/A	2 Relays, Analog
5770X464	1/8 DIN	J,K,T & 4-wire RTD	N/A	RS-485
5770X465	1/8 DIN	J,K,T & 4-wire RTD	N/A	2 Relays, RS-485
5770X466	1/8 DIN	J,K,T & 4-wire RTD	N/A	Analog, RS-485
5770X467	1/8 DIN	J,K,T & 4-wire RTD	N/A	2 Relays, Analog, RS-485

① Items will normally ship within one week.

•Input Power
9 – 30 Vdc for 5770046X
85 – 265 Vac for 577014XX

Special Function Controls

The Fusion™ is the integrated machine control — a unique concept which incorporates three functions into one box — high speed count control, totalizing, batching and ratemeter operations, and is the most versatile industrial counter available anywhere. The operator interface consists of an entirely programmable multiline, multi-screen display of control data, alarms, operator prompts, and management information, and 18 front panel keys, 11 of which can

be used as pushbutton control inputs. The ladder logic processor evaluates hardware and keypad inputs, along with internal counters, timers, analog comparators, and a real-time clock. The Fusion is the single box answer to assemblies made up of counters, timers, pushbuttons, power supplies, and programmable relays for cut-to-length, liquid batching, pump staging, coil winding, and numerous other applications.

Integrated Machine Control

- Operator interface:
 - 3-, 4-, 5-line backlit LCD display
 - 8 display screens
 - 18-button tactile feedback keypad
- High speed counter:
 - 6-digit main counter with 5 presets and prewarn
 - 8-digit totalizer with preset
 - 6-digit batch counter with preset
 - 5-digit ratemeter with high and low set points
 - 10 parameter sets
- Ladder logic processor:
 - 13 digital inputs
 - 2 4 – 20 mA inputs
 - 1 0 – 10 V inputs
 - 11 keypad inputs
 - 8 counters
 - 8 timers
 - 8 analog comparators
 - 8 real-time clock ranges
- Counter/ladder outputs
 - 3 Form C relays
 - 2 Form A relays
 - 2 NPN transistors
 - 1 4 – 20 mA analog
 - 1 0 – 10 V analog
- 12 Vdc and 24 Vdc accessory power out
- RS-232 and RS-485 serial communications
- 85 – 265 Vac and 10 – 30 Vdc models available
- NEMA 4X enclosure
- UL, cUL listed, CE marked



57551400

SPECIAL FUNCTION CONTROLS SELECTION CHART

Order Number	Description
Integrated Machine Control	
57550400	Count/Logic Machine Control, 10 – 30 Vdc
57551400	Count/Logic Machine Control, 85 – 265 Vac
57590400	Fusion Configuration Software
Basic Monitor Control	
54420400	BASIC Monitor Control, 115/230 Vac or 11 – 16 Vdc
500 Level Sequence Controller	
56460400	Sequential Controller, 85 – 265 Vac

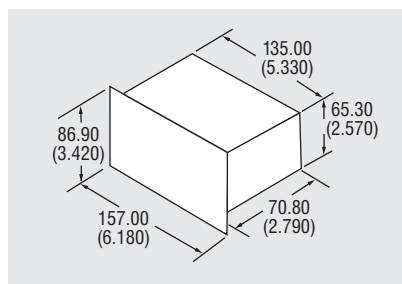

Panel Cutout: 138 x 68 (5.433 x 2.677)
Approximate in mm (inches).

Durant does its own plastic molding.



The BASIC monitor control (BMC) has two count inputs. Eight other rear terminal inputs and the 14 front panel keys are user definable. The same is true for the two relay and five transistor outputs. Configuration is done through a BASIC language program entered by the user, putting the BMC in specialized control applications where dedicated count controls are not as well suited. The 6460

sequential control can be thought of as a counter and/or timer with 500 presets. Most users load a number of programs or "recipes" into the 6460 and have the operator select one recipe at a time to run. The 6460 is often found in roll forming and coil winding applications and is used on induction heat treating scanners.



54420400

BASIC Monitor Control

- 6-digit, LED display, 14 mm (0.56") high characters
- User defined operation
- Utilizes BASIC language
- Outputs:
 - 4 NPN transistors
 - 2 Form C relays
 - 1 pulse-width modulated
- 8 input lines
- 8k bytes of programmable memory
- 15 Vdc, 100 mA maximum output power
- 20 mA current loop communication
- Accepts 115/230 Vac and 11 – 16 Vdc input power
- NEMA 4 front panel



56460400

500 Level Sequence Controller

- 500 programming levels
- 32 character, 2-line LCD display 7.9 mm (.315") high characters
- 17 programmable count modes
- 4 programmable jump inputs
- Millisecond timing
- Count scaling
- Rate, total and batch count
- 16 NPN outputs
- 24 Vdc at 800 mA and 15 Vdc at 200 mA output power
- RS-232 communications
- 85 – 265 Vac and 24 Vdc input power models
- Optional configuration software available
- NEMA 4 accessory kit
- UL, cUL listed, CE marked

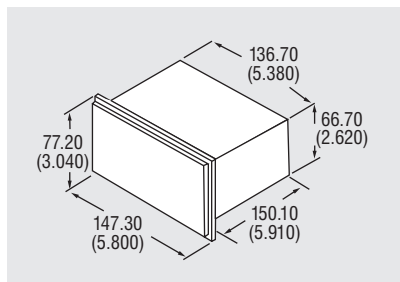

Panel Cutout: 138 x 68 (5.433 x 2.677)
Approximate in mm (inches).

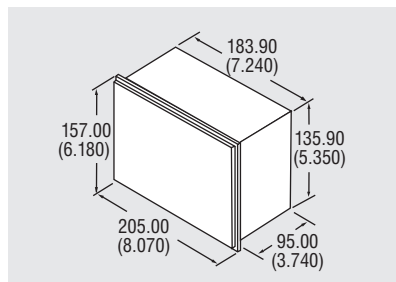

Panel Cutout: 186 x 138 (7.320 x 5.430)
Approximate in mm (inches).

Specialty Products

Durant makes a number of products designed to meet the needs of specialized count and rate applications. When shift count, day count, machine run time, etc. are required, the **productivity monitor** is used. One monitor per machine provides the raw data to a central PC for real-time production monitoring and report generation. The **feet/inches totalizer** displays length or position,

and the **feet/inches control** provides outputs at predetermined lengths, measured in feet and inches. Where precise, master or follower rate control is required, we offer the **closed loop speed control**. Accurate positioning is accomplished with the **single axis position control**.



57201420

Productivity Monitor

- 2-line, 16-character, alphanumeric backlit LCD display, 7.5 mm (0.3") high characters
- 6-decade batch counter with preset time until batch complete feature
- 2 8-decade totalizers
- 6-decade ratemeter
- 12 Vdc power output, 100 mA maximum
- Provides real-time productivity data
- Run and downtime tracking
- Time efficiency tracking
- Operator, job and part identification features
- 115 Vac and 230 Vac input power models
- NEMA 4 front panel
- UL, CSA listed
- CE marked
- For configuration software, see ProFile, **Page 37**



57810402

Feet/Inches Totalizer

- 7-digit, red LED display, 14 mm (0.56") high characters
- Display modes:
 - Feet and inches
 - Feet, inches, and 1/10 of inches
 - Feet, inches, and 1/100 of inches
 - Feet, inches, and 1/16 of inches
 - Meters and millimeters
- 15 Vdc power output, 85 mA maximum
- Quadrature count input only
- 3000 Hz count input frequency
- Screw terminal connections
- Accepts 115 Vac and 11 – 30 Vdc input power
- NEMA 4 front panel



57601415

Feet/Inches Control

- 2-line, 16-character, alphanumeric backlit LCD display, green or red 7.5 mm (0.3") high characters
- 3 presets and prewarn
- Prewarn tracks final preset
- Totalizer and batch functions
- 2 Form C relay outputs
- 2 NPN transistor outputs
- 12 Vdc power output, 100 mA maximum
- Displays in feet and inches
- 4 programmable control inputs
- Removable screw terminals
- 115 Vac and 230 Vac input power models
- RS-485 serial communications
- NEMA 4 front panel
- UL, CSA listed
- CE marked
- For configuration software, see ProFile, **Page 37**

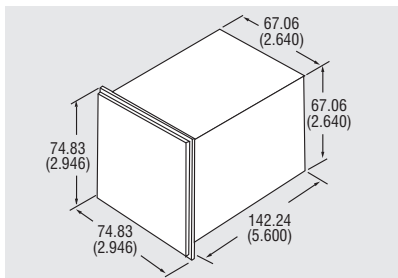

Panel Cutout: 68 x 68 mm (2.677 x 2.677)
Approximate in mm (inches).

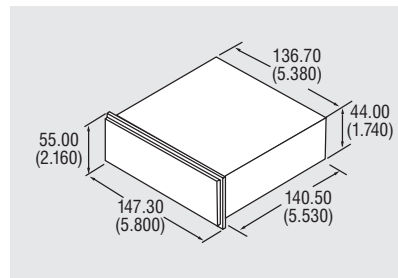

Panel Cutout: 45 x 138 mm (1.770 x 5.430)
Approximate in mm (inches).

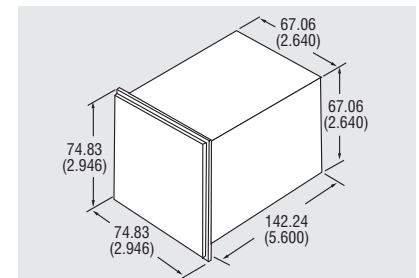

Panel Cutout: 68 x 68 mm (2.677 x 2.677)
Approximate in mm (inches).



57401400

Closed Loop Speed Control

- 2-line, 16 character, alphanumeric high visibility, LCD backlit, 7.5 mm (0.3") high character display
- 1 or 2 speed presets
- Isolated 0 – 10 Vdc analog out
- Selectable master/slave/jog modes
- Proportional integral error correction
- 35 kHz frequency inputs
- ±0.015% speed regulation
- 12 Vdc at 125 mA power output
- Tach loss safety feature
- 12-bit DAC resolution
- RS-485 serial communications
- 115 and 230 Vac input power models
- NEMA 4X front panel
- UL listed
- For configuration software, see ProFile, Page 37

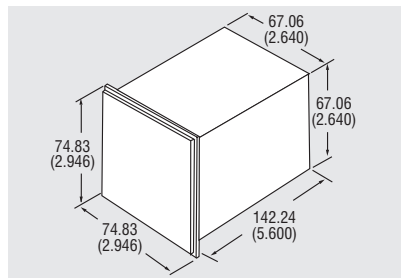

Panel Cutout: 68 x 68 mm (2.677 x 2.677)
Approximate in mm (inches).



58868400

Single Axis Position Control

- 6-digit, LED display, 14 mm (0.56") high characters
- 4 move registers plus home
- 2 Form C relay and 5 NPN transistor outputs
- 28 kHz count speed
- 5 dwell time settings
- Manual or automatic operation
- Programmable offset, prewarn, and kerf values
- Backlash compensation
- Programmable high/low position limits
- 15 Vdc at 100 mA power output
- Accepts 115/230 Vac, 11 – 28 Vdc input power
- 20 mA current loop communications
- NEMA 4X front panel

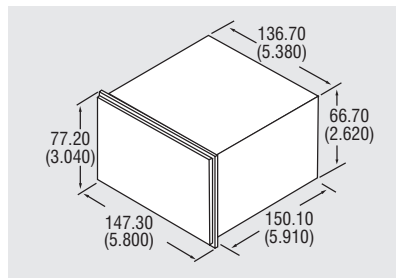

Panel Cutout: 68 x 138 mm (2.677 x 5.430)
Approximate in mm (inches).

Specialty Products (continued)

SPECIALTY PRODUCTS SELECTION CHART

Order Number	Description
Productivity Monitor	
57201420 i	Productivity Monitor, 115 Vac
57201421 i	Productivity Monitor, 8 Reason Inputs, 115 Vac
57202420	Productivity Monitor, 230 Vac
57202421	Productivity Monitor, 8 Reason Inputs, 230 Vac
Feet/Inches Totalizer	
57810402	Feet/Inches Totalizer
Feet/Inches Control	
57601415	Feet/Inches Control, 115 Vac
57602415	Feet/Inches Control, 230 Vac
Closed Loop Speed Control	
57401400 i	Speed Control, 1 Preset, 115 Vac
57401401 i	Speed Control, 2 Presets, 115 Vac
57402400	Speed Control, 1 Preset, 230 Vac
57402401	Speed Control, 2 Presets, 230 Vac
Single Axis Position Control	
58868400 i	Single Axis Position Control

i Items will normally ship within one week.

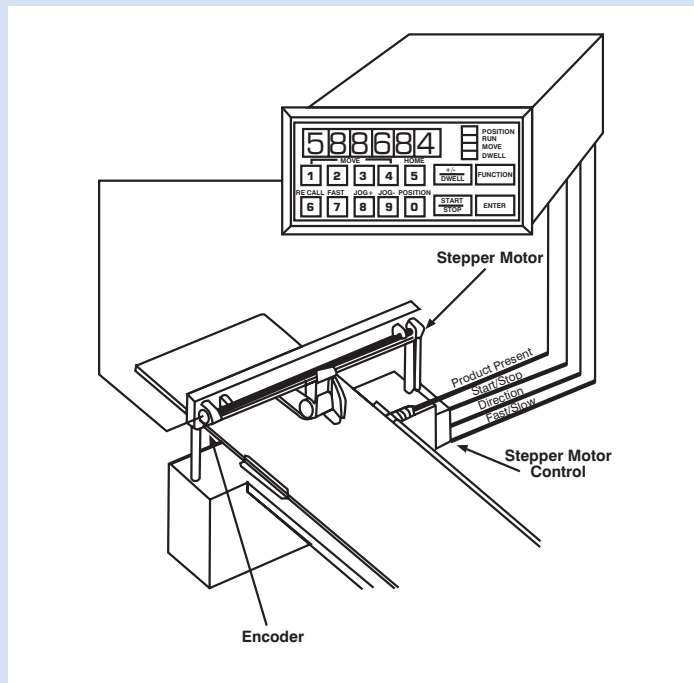

Sawblade Positioning Application

In the sawblade positioning application, the saw is mounted to a ball screw that is turned by a motorized drive system. The ball screw has a 100 pulse per revolution shaft encoder mounted to it. Motion is tracked through the selection of a quadrature encoder.

The operator selects the position to move the saw by pressing one of the move register or home position buttons on the Durant motion controller. When a piece of material is in the machine and the operator presses the remote Start Button, the Durant unit will configure the Run, Forward/Reverse and Fast outputs to cause the stepper control to move the saw to the correct position.

A final board inspection makes sure it is ready to go to the final assembly area.



Wire and Cable Lay Control

To control lay (inches per twist) of a cable, it is necessary to control the line speed of the cable based on the speed of the twister. A motor controlling twister speed provides an external reference signal to the speed control. The speed control, in the Follower mode, provides the appropriate analog drive signal to the adjustable frequency drive. The drive adjusts the line speed motor accordingly. An encoder provides the feedback signal for speed regulation.



Motor Speed Control

The motor speed control, in the master mode, controls the speed of the motor. The speed set point is entered on the front panel keypad. A zero to 10 volt analog drive signal is sent to the adjustable frequency drive. The drive controls the speed of the motor accordingly. The C-Flange sensor kit provides a frequency feedback signal back to the speed control to close the loop and allow accurate speed regulation.

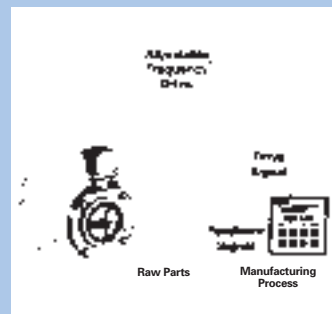

Baking Oven Conveyor Control

The speed of the conveyor belt must be precisely controlled to ensure the right amount of baking time for each loaf of bread. The speed control, in the master mode, sets the desired speed and provides the necessary analog drive signal to the adjustable frequency drive. The drive controls the motor driving the belt. A frequency feedback signal is used to ensure precise belt speed control. The use of the inverse preset function allows the operator to set the speed in terms of minutes of baking time.

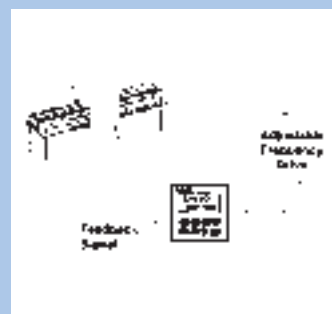

Transducers

All electronic counting devices require a count source to supply pulses that the counter converts to numbers on the display. These pulses are usually supplied by some sort of transducer.

A transducer electronically converts a mechanical action to pulses. Encoders, contactors and magnetic pickups are examples of transducers.



38150100

Shaft Encoder — Cube

- 5 – 28 Vdc input power
- 80 mA current draw
- NPN transistor output, 250 mA sinking capacity
- Square wave output
- Single channel and quadrature models
- Many pulse per revolution (PPR) options, see **Page 33**

- 3/8" double-ended shaft
- 6000 RPM maximum shaft speed
- 40 lbs. maximum radial shaft loading
- 30 lbs. maximum axial shaft loading
- ABEC 3 double-sealed ball bearings

- Tapped holes for face or base mounting
- 0 to 70°C operating temperature
- Military style connector
- Connector and cable accessories
- Mounting bracket accessory
- Measuring wheel accessory



48371600

Shaft Encoder — Heavy Duty

- 5 – 28 Vdc input power
- 80 mA current draw
- NPN transistor output, 250 mA sinking capacity
- Square wave output
- Single channel and quadrature models

- Many pulse per revolution (PPR) options, see **Page 33**
- 3/8" single-ended shaft
- 6000 RPM maximum shaft speed
- 50 lbs. maximum radial shaft loading
- 35 lbs. maximum axial shaft loading

- ABEC 3 double-sealed ball bearings
- Tapped holes for face or base mounting
- 0 to 70°C operating temperature
- Military style connector
- Connector and cable accessories
- Measuring wheel accessory



38159600

Shaft Encoder — Size 20

- 5 – 28 Vdc input power
- 100 mA current draw
- NPN transistor output, 100 mA sinking capacity
- Quadrature output only, 2 square waves
- Up to 1800 pulses per revolution (PPR), see **Page 33**

- Flange mounting
- 3/8" shaft diameter
- 8000 RPM maximum shaft speed
- 80 lbs. maximum radial shaft loading
- 80 lbs. maximum axial shaft loading
- Double-shielded ball bearings

- 0 to 70°C operating temperature
- Military style connector
- Connector and cable accessories

Automatic inline Takaya testing ensures only good boards get to final assembly.



Vane Pickup

- 10 – 15 Vdc input power
- 35 mA current draw
- 10-foot shielded cable
- Environmentally sealed
- 3000 Hz maximum speed



39400400

Rotary Contacter

- No power required
- Reed switch output models for electronic counters
- Contact closure output
- Leaf switch output models for electromechanical counters
- 5/16" double shaft, 2400 RPM maximum at 1:1 ratio
- Standard ratios: 1:1, 1:3, 1:10, 10:1, 12:1, 1:3.28 (counts: revolution)
- 12" wire leads
- Mounting bracket accessory
- Measuring wheel accessory



39100400



39100400 shown with mounting bracket and measuring wheel.

Transducers (continued)



47007256

C-Face Ring Tachometer

- 5 – 16 Vdc input power
- NPN transistor output, 20 mA sinking capacity
- 60 PPR
- Zero speed pickup
- Variety of motor C-face sizes: 56, 184, 254 or 256
- 4 to 107°C operating temperature



47004400 Magnetic Pickup
with L Bracket

28433400 30-Tooth Gear

Magnetic Pickup

- 1/2" diameter
- Ideal for tachometer and rate control applications
- -40 to 148°C operating temperature
- Output is ac signal
- Output amplitude is proportional to speed of target
- 10-foot cable attached
- L mounting bracket included

30-Tooth Gear Accessory

- 1.6" diameter
- 0.375" bore diameter
- Mounting set screw included



TRANSDUCERS SELECTION CHART

Order Number	Pulses Per Revolution	Input Power	NPN Output	Contact Output	Quadrature	Shaft	Description
Shaft Encoder — Cube **							
38150060 ①	60	5 – 28 Vdc	•			3/8"	Encoder, Cube
38150100 ①	100	5 – 28 Vdc	•			3/8"	Encoder, Cube
38150120 ①	120	5 – 28 Vdc	•			3/8"	Encoder, Cube
38150600 ①	600	5 – 28 Vdc	•			3/8"	Encoder, Cube
38151060 ①	60	5 – 28 Vdc	•		•	3/8"	Encoder, Cube
38151100 ①	100	5 – 28 Vdc	•		•	3/8"	Encoder, Cube
38151120 ①	120	5 – 28 Vdc	•		•	3/8"	Encoder, Cube
38151600 ①	600	5 – 28 Vdc	•		•	3/8"	Encoder, Cube
Encoder Accessories							
29665300 * ①							Connector, Encoder, 10' Cable
29729300 ①							Connector, Encoder, No Cable
40460402 ①							Mounting Bracket, Encoder
Shaft Encoder — Heavy Duty							
48370060	60	5 – 28 Vdc	•			3/8"	Encoder, Heavy Duty
48370100	100	5 – 28 Vdc	•			3/8"	Encoder, Heavy Duty
48370120	120	5 – 28 Vdc	•			3/8"	Encoder, Heavy Duty
48370600	600	5 – 28 Vdc	•			3/8"	Encoder, Heavy Duty
48371060	60	5 – 28 Vdc	•		•	3/8"	Encoder, Heavy Duty
48371100	100	5 – 28 Vdc	•		•	3/8"	Encoder, Heavy Duty
48371120	120	5 – 28 Vdc	•		•	3/8"	Encoder, Heavy Duty
48371600	600	5 – 28 Vdc	•		•	3/8"	Encoder, Heavy Duty
Shaft Encoder — Size 20 **							
38159100	100	5 – 28 Vdc	•		•	3/8"	Encoder, Size 20
38159120	120	5 – 28 Vdc	•		•	3/8"	Encoder, Size 20
38159600	600	5 – 28 Vdc	•		•	3/8"	Encoder, Size 20
381591000	1000	5 – 28 Vdc	•		•	3/8"	Encoder, Size 20
381591800	1800	5 – 28 Vdc	•		•	3/8"	Encoder, Size 20
Vane Pickup							
39400400 ①		10 – 15 Vdc	•				Vane Pickup, 10' Cable
Rotary Contactor							
39100400 ①	12:1			•		5/16"	Reed Switch Output
39100401 ①	10:1			•		5/16"	Reed Switch Output
41100400 ①	1:1			•		5/16"	Reed Switch Output
41100401 ①	1:3			•		5/16"	Reed Switch Output
41100402	1:3.28			•		5/16"	Reed Switch Output
41100403	1:10			•		5/16"	Reed Switch Output
40891400 ①	1:1			•		5/16"	Leaf Switch Output
40892400	1:10			•		5/16"	Leaf Switch Output
40892401	1:3			•		5/16"	Leaf Switch Output
C-Face Ring Tachometer							
47007056	60	5 – 16 Vdc	•				C-Face Sensor, Motor Size 56C
47007184	60	5 – 16 Vdc	•				C-Face Sensor, Motor Sizes 143TC, 145TC, 182C, 184C
47007215	60	5 – 16 Vdc	•				C-Face Sensor, Motor Sizes 182TC, 184TC, 213C, 215C, 254C
Magnetic Pickup							
47004400 ①							Magnetic Pickup
Magnetic Pickup Accessory							
28433400 ①							30-Tooth Gear for Magnetic Pickup

- ① Items will normally ship within one week.
- Measuring wheels for encoders and contactors listed on Page 36.
- * Other cable lengths available — consult factory.
- ** Other PPR available — consult factory.

Accessories — Solid-State Relays

Solid-State Relays (SSRs) are devices to be used when an application involves highly repetitive switching of voltage or current. Because there are no moving parts, they don't wear out. Typical applications include heater controls, valve controls, and solenoid

valve controls — anywhere that high voltage/current switching is required. Durant offers a variety of SSRs, including hockey pucks and DIN rail models.



E45DR17

17.5 mm Model: Single-Phase

- Triac output, 12 – 280 Vac or 5 – 48 Vdc
- ac output rating 5 A
- dc output rating 3 A
- Input voltage 4 – 32 Vdc regulated
- 4 kV optical isolation
- LED display of input status
- Replaceable protection fuse
- UL/CSA listed
- CE marked

45 mm Model: Single-Phase

- Dual SCR output, 48 – 660 Vrms
- Output rating 34 A ac and 35 A dc
- Input voltage 90 – 280 Vac and 4 – 32 Vdc
- RC filter protection
- LED display of input status
- 4 kV optical isolation
- -20 to 80°C operating temperature
- UL/CSA listed
- CE marked



E45DR22

22.5 mm Model: Single-Phase

- Triac output, 24 – 240 Vac or 4 – 32 Vdc
- Output rating 12 – 25 A
- Input voltage 90 – 280 Vac or 4 – 32 Vdc
- RC filter protection
- LED display of input status
- 4 kV optical isolation
- -20 to 80°C operating temperature
- UL/CSA listed
- CE marked

90 mm Model: Three-Phase

- Dual SCR output, 48 – 660 Vrms
- Output rating 3 x 25 A
- Input voltage 90 – 280 Vac and 4 – 32 Vdc
- RC filter protection
- LED display of input status
- 4 kV optical isolation
- -20 to 80°C operating temperature
- UL/CSA listed
- CE marked



E45DR45



E45DR90

DIN RAIL MOUNTED SOLID-STATE RELAY SELECTION CHART

Order Number	Rating	Output Voltage to be Controlled	Control Voltage	Triac	Thyristor	DIN Rail
Single-Phase Solid-State Relay						
E45DR17X48D3	3 A	5 – 48 Vdc	4 – 32 Vdc	•		17.5 mm
E45DR17T280D5	5 A	12 – 280 Vac	4 – 32 Vdc	•		17.5 mm
E45DR22T280A25	20 A	24 – 280 Vac	90 – 280 Vac/dc	•		22.5 mm
E45DR22T280D25	20 A	24 – 280 Vac	4 – 32 Vdc	•		22.5 mm
E45DR22S280D25	25 A	48 – 660 Vac	4 – 32 Vdc		•	22.5 mm
E45DR45S660D35	35 A	48 – 660 Vac	4 – 32 Vdc		•	45 mm
Three-Phase Solid-State Relay						
E45DR90S660A3X25	25 A	48 – 660 Vac	90 – 280 Vac		•	90 mm
E45DR90S660D3X25	25 A	48 – 660 Vac	4 – 32 Vdc		•	90 mm

• Items will normally ship within one week.



E45R

Single-Phase SSRs

- Current ratings to 100 amps
- Output voltage ratings to 660 Vac
- 90 – 280 Vac control voltage models
- 3 – 32 Vdc control voltage models
- Triac output models for general purpose applications
- Dual SSR output models for severe inductive loads
- FET output model for dc loads up to 30 A
- Transistor output model for dc loads up to 10 A

- -20 to 80°C operating temperature
- 4 kV optical isolation
- Industry standard package
- CE marked all models



E45RA

Three-Phase SSRs

- 45 A output per channel models
- 4 – 32 Vdc input voltage model
- 90 – 280 Vac input voltage model
- 24 – 660 Vac output voltage range
- 1200 V peak blocking voltage
- -30 to 80°C operating temperature
- Internal RC snubber network
- 4 kV optical isolation
- Industry standard package
- CE marked

BASE MOUNTED SOLID-STATE RELAY SELECTION CHART

Order Number	Line Voltage	Control Voltage	Output Rating	Switching Type	Heat Sink	Cover	Thermstrate
SCR Output							
E45R240A10	24 – 280 Vac	90 – 280 Vac	10 A	Zero Crossing	E45RHS2 (2.0 C/W) or E45RHS4 (1.0 C/W)	E45RSSRC	E45RHSP1
E45R240A25 ①	24 – 280 Vac	90 – 280 Vac	25 A	Zero Crossing	E45RHS2 (2.0 C/W) or E45RHS4 (1.0 C/W)	E45RSSRC	E45RHSP1
E45R240D10	24 – 280 Vac	3 – 32 Vdc	10 A	Zero Crossing	E45RHS2 (2.0 C/W) or E45RHS4 (1.0 C/W)	E45RSSRC	E45RHSP1
E45R240D25	24 – 280 Vac	3 – 32 Vdc	25 A	Zero Crossing	E45RHS2 (2.0 C/W) or E45RHS4 (1.0 C/W)	E45RSSRC	E45RHSP1
E45R240D45	24 – 280 Vac	3 – 32 Vdc	50 A	Zero Crossing	E45RHS2 (2.0 C/W) or E45RHS4 (1.0 C/W)	E45RSSRC	E45RHSP1
E45R240D75 ①	24 – 280 Vac	3 – 32 Vdc	75 A	Zero Crossing	E45RHS2 (2.0 C/W) or E45RHS4 (1.0 C/W)	E45RSSRC	E45RHSP1
E45R660A90	48 – 660 Vac	90 – 280 Vac	100 A	Zero Crossing	E45RHS2 (2.0 C/W) or E45RHS4 (1.0 C/W)	E45RSSRC	E45RHSP1
E45R660D50 ①	48 – 660 Vac	4 – 32 Vdc	50 A	Zero Crossing	E45RHS2 (2.0 C/W) or E45RHS4 (1.0 C/W)	E45RSSRC	E45RHSP1
E45R240D45R	24 – 280 Vac	3 – 32 Vdc	50 A	Asynchronous	E45RHS2 (2.0 C/W) or E45RHS4 (1.0 C/W)	E45RSSRC	E45RHSP1
E45R660D50R	48 – 660 Vac	4 – 32 Vdc	50 A	Asynchronous	E45RHS2 (2.0 C/W) or E45RHS4 (1.0 C/W)	E45RSSRC	E45RHSP1
Triac Output							
E45RA56A25	24 – 280 Vac	90 – 280 Vac	25 A	Zero Crossing	E45RHS2 (2.0 C/W) or E45RHS4 (1.0 C/W)	E45RSSRC	E45RHSP1
E45RA56D25	24 – 280 Vac	3 – 32 Vdc	25 A	Zero Crossing	E45RHS2 (2.0 C/W) or E45RHS4 (1.0 C/W)	E45RSSRC	E45RHSP1
Transistor Output							
E45RT60D10 ①	3 – 60 Vdc	3 – 32 Vdc	10 A		E45RHS2 (2.0 C/W) or E45RHS4 (1.0 C/W)	E45RSSRC	E45RHSP1
Three-Phase SCR Output							
E45RA312A45 ①	24 – 660 Vac	90 – 280 Vac	45 A	Zero Crossing	E45RHS1 (1.5 C/W) or E45RHS7 (0.9 C/W)	E45RSSRC2	E45RHSP3
E45RA312D45 ①	24 – 660 Vac	4 – 32 Vdc	45 A	Zero Crossing	E45RHS1 (1.5 C/W) or E45RHS7 (0.9 C/W)	E45RSSRC2	E45RHSP3

① Items will normally ship within one week.

Accessories — Other



Measuring Wheels

- For use with our shaft encoders and rotary contactors
- 12-inch, 18-inch, or 1/3-meter circumference
- Urethane, rubber or knurled edges
- 5/16 or 3/8-inch bores
- Aluminum or hardened steel material

Models

- 20144300 12-inch urethane, 5/16-inch bore
- 20144303 12-inch urethane, 3/8-inch bore
- 20154300 12-inch rubber, 5/16-inch bore
- 20154301 12-inch rubber, 3/8-inch bore
- 20156300 12-inch knurled, 5/16-inch bore
- 20156301 12-inch knurled, 3/8-inch bore
- 21665300 18-inch knurled, 5/16-inch bore
- 21666300 18-inch rubber 5/16-inch bore
- 20148300 18-inch urethane, 5/16-inch bore
- 36074301 1/3-meter rubber, 5/16-inch bore



58801440

Communications Adapter Module

- Interfaces smart wand at 9600 baud
- Network communications at 19200 baud
- 120/240 Vac input power
- Optical isolation
- 5.25 x 3.90 x 2.25 inches (W x H x D)



58801461

Serial Communications Converter

- Intended for use as an interface between devices with different communications formats
- RS-232 to RS-485 conversion up to 19,200 baud
- RS-232 to 20 mA current loop conversion up to 19,200 baud
- RS-485 to RS-485 conversion up to 76,800 baud
- 120/240 Vac input power
- Optical isolation
- 5.25 x 3.90 x 2.25 inches (W x H x D)



49750400

15 Vdc Power Supply

- 120 Vac, 50/60 Hz power input
- 15 ±1 Vdc at 300 mA maximum output
- 50 mV peak-to-peak ripple
- 2.25 x 1.75 x 3.50 inches (W x H x D)



49990408

Simultaneous Input Processor

- Ensures that all counts are recorded when multiple count sources are required
- Count pulses can occur simultaneously
- All accumulated count pulses are sent out serially
- 15 Vdc input power
- 8 count inputs
- 120 Hz maximum count input speed per input
- NPN transistor output
- 4.25 x 4.50 x 1.75 inches (W x H x D)



38091400

Surge Suppressor

- The installation of suppression devices on inductive loads is required in industrial control applications
- Suppressors will extend the life of relay contacts and reduce the effects of electrical noise on electronic count controls
- Typical inductive loads that require suppression include solenoids, solenoid valves, relay coils, motor starters and small motors
- More than one suppressor can be wired in parallel with large inductors where one suppressor is not sufficient



57624450

ProFile Configuration Software

Programming software for:

- 5760xxxx series counters
- 5720xxxx series productivity monitors
- 5715xxxx series ratemeters
- 5740xxxx series speed controls
- 5770xxxx series DPMs, ratemeters and counters
- 5775xxxx series flow totalizers and batch controls

Accessories — Other (continued)



48160400

Signal Conditioner

- Converts a wide range of input signals to a level compatible with most Durant count/controls
- 5 – 25 Vdc input power
- Differential inputs
- Ground referenced input
- NPN transistor output
- Signal level adjustment
- 1.25 x 2.50 x 1.75 inches (W x H x D)



Voltage Adapters

Voltage Adapters

- E40VOLTC Voltage Adapter for the E402400 — permits use of high voltage input pulses from 5 – 240 Vac or dc
- E40VOLTT Voltage Adapter for the E42DI2475-S/H Timers —

permits use of high voltage input pulses from 5 – 240 Vac or dc for enable and reset inputs — provides input to output isolation of 5000 V

- E40QUAD Quadrature Adapter for the E402410 —

converts quadrature signals into a count with direction control signal

- E40TERM provides screw terminal connections for conductors up to 14 gauge



48160450

Analog to Frequency Converter

- Converts single-ended variable dc voltage or current signals to a variable frequency output signal
- 10 – 30 Vdc input power
- 0 – 10 kHz output frequency range
- Gain adjustment
- Offset adjustment
- 2.75 x 2.50 x 0.70 inches (W x H x D)



48160480

Frequency to Analog Converter

- Changes a variable pulse input to a variable analog output
- 12 – 15 Vdc input power
- Source or sink input capability
- Differential or single ended inputs
- 0 – 10 Vdc output
- 4 – 20 mA output
- 2.75 x 2.50 x 0.70 inches (W x H x D)
- 0 – 10 kHz input range

Custom design work is done to meet specific requirements.



ACCESSORIES SELECTION CHART

Order Number	Size	Bore	Input	Power	Description
20144300 ①	1ft.	5/16"	N/A	N/A	Measuring Wheel, Urethane Rim
20144303 ①	1ft.	3/8"	N/A	N/A	Measuring Wheel, Urethane Rim
20154300 ①	1ft.	5/16"	N/A	N/A	Measuring Wheel, Rubber Rim
20154301 ①	1ft.	3/8"	N/A	N/A	Measuring Wheel, Rubber Rim
20156300 ①	1ft.	5/16"	N/A	N/A	Measuring Wheel, Knurled Rim
20156301 ①	1ft.	3/8"	N/A	N/A	Measuring Wheel, Knurled Rim
36074301	1/3 m	5/16"	N/A	N/A	Measuring Wheel, Rubber Rim
58801440	N/A	N/A	120/240 Vac	N/A	Communications Adapter Module, Screw Terminal Power Input
58801460 ①	N/A	N/A	N/A	120	Communications Converter, Power Cord
58801461 ①	N/A	N/A	N/A	120/240 Vac	Communications Converter, Screw Terminal Power Input
49750400 ①	N/A	N/A	120 Vac	N/A	Power Supply, 15 Vdc
49990408	N/A	N/A	Contact or NPN	15 Vdc	Simultaneous Input Processor, 8 Inputs
38091400 ①	N/A	N/A	N/A	N/A	Surge Suppressor
57624450	N/A	N/A	N/A	N/A	Configuration Software
48160400 ①	N/A	N/A	0.05 – 300 V P-P	5 – 25 Vdc	Signal Conditioner Module
48160450 ①	N/A	N/A	0 – 55 Vdc 0 – 30 mA	10 – 30 Vdc	Analog-Frequency Converter, 0 – 10 kHz Output Range
48160451 ①	N/A	N/A	0 – 100 Vdc 0 – 30 mA	10 – 30 Vdc	Analog-Frequency Converter, 0 – 2.5 kHz Output Range
48160480 ①	N/A	N/A	0 – 10 kHz	12 – 15 Vdc	Frequency-Analog Converter, 0 – 10 kHz Input Range
48160481 ①	N/A	N/A	0 – 2.5 kHz	12 – 15 Vdc	Frequency-Analog Converter, 0 – 2.5 kHz Input Range
E45RHSP1	N/A	N/A	N/A	N/A	Heat Sink Mounting Pad for E45R, E45RA5, E45RF and E45RT
E45RHSP3 ①	N/A	N/A	N/A	N/A	Heat Sink Mounting Pad for E45RA0 and E45RA3
E45RSSRC ①	N/A	N/A	N/A	N/A	Clear Cover for E45R, E45RA5, E45RF and E45RT
E40VOLT C ①	N/A	N/A	5 – 240 Vac or dc	N/A	Voltage Adapter for the E402400
E40VOLT T ①	N/A	N/A	5 – 240 Vac or dc	N/A	Voltage Adapter for the E42DI2475 Timers
E40TERM ①	N/A	N/A	N/A	N/A	Provides Screw Terminal Connections for Conductors Up to 14 Gauge
E40QUAD ①	N/A	N/A	N/A	N/A	Converts the Quadrature Count Signals for E40210

① Items will normally ship within one week.

ISO is the registered trademark and sole property of the International Organization for Standardization. • NEMA is the registered trademark and service mark of the National Electrical Manufacturers Association. • UL and cUL are federally registered trademarks of Underwriters Laboratories Inc. • CSA is a registered trademark of the Canadian Standards Association. • Moeller and Easy are federally registered trademarks of Moeller Electric Corporation. • Red Lion is a federally registered trademark of Spectris.

Eaton's Electrical business is a global leader in electrical control, power distribution, and industrial automation products and services. Through advanced product development, world-class manufacturing methods, and global engineering services and support, Eaton's Electrical business provides customer-driven solutions under brand names such as Cutler-Hammer[®], Durant[®], Heinemann[®], Holec[®] and MEM[®], which globally serve the changing needs of the industrial, utility, light commercial, residential, and OEM markets. For more information, visit www.EatonElectrical.com.

Eaton Corporation is a diversified industrial manufacturer with 2003 sales of \$8.1 billion. Eaton is a global leader in fluid power systems and services for industrial, mobile and aircraft equipment; electrical systems and components for power quality, distribution and control; automotive engine air management systems and powertrain controls for fuel economy; and intelligent drivetrain systems for fuel economy and safety in trucks. Eaton has 54,000 employees and sells products to customers in more than 100 countries. For more information, visit www.eaton.com.

Eaton Electrical Inc.
1000 Cherrington Parkway
Moon Township, PA 15108
United States
tel: 1-800-525-2000
www.EatonElectrical.com

Durant Products
901 South 12th St.
Watertown, WI 53094
920-261-4070
fax: 920-261-9097
tel: 1-800-540-9242
www.durant.com

