

# SealSmart II™ Instructions

©2010 Platinum Tools Inc. All rights reserved. 7/10

# PLATINUM TOOLS®

- 1) Strip & prep cable following instructions in connector packaging.
- 2) Snap cable into tool's compression sleeve support. (Fig A)
- 3) Slide connector down onto cable until flush with connector seat. Adjust cable to proper position within connector. (Fig B)
- 4) Rotate adaptor head down onto connector and secure lock washer against adaptor plunger. Position & hold tool handle at approx. 45° during this step. (Fig C)

**Tip:** If connector is too long to fit into SealSmart II with adaptor head wide open, remove lock washer for additional space.

- 5) Compress handle until fully closed. Do not under or over crimp.

Adjust adaptor head, if necessary, for more compression then squeeze handle again.

Back off adaptor head if after compression, tool handle is not fully closed but connector is fully seated. Tool handle should finish in closed position.

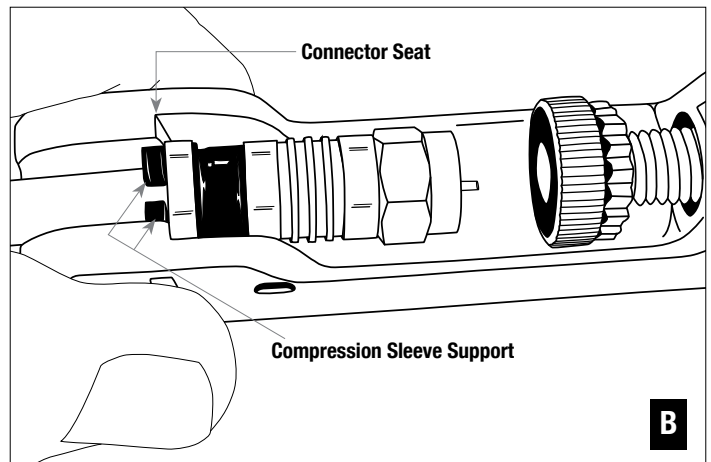
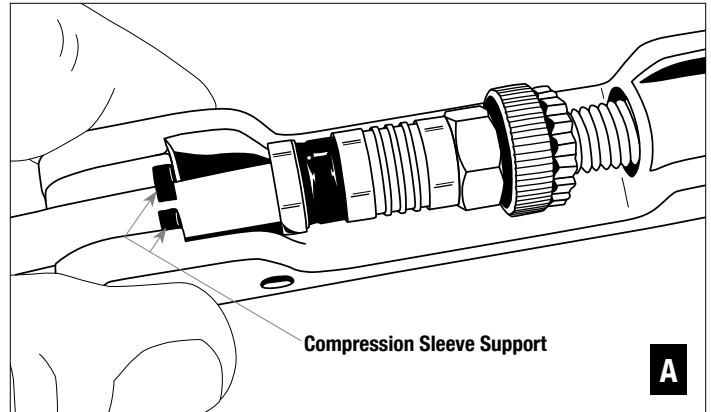

## Smart Tip:

Create crimped templates of your most commonly used connectors that can be placed into the SealSmart II for quick adaptor head adjustment. Work faster without having to guess the head adjustment of your next connector job.

