

## Antenna Installation Guide

### Warranty Information

This product carries a limited 90 day warranty, which does not apply if the product has been damaged, deteriorates, malfunctions or fails from: improper installation, misuse, abuse, neglect, accident, tampering, modification of the product as originally manufactured by Stellar Labs® in any manner whatsoever, usage not aligned with product instructions or acts of nature such as damage caused by wind, lightning, ice or corrosive environments such as salt spray and acid rain. This Limited Warranty also does not apply if the product becomes unable to perform its' intended function in any way as a result of the television signal provider making any changes in technology or service. Should a failure be determined covered by the warranty, it will be the sole discretion of MCM Electronics to repair or replace the product. This warranty covers the product only, and does not include any additional product or expense incurred. No liability outside the product itself is implied.

### RETURN AUTHORIZATION POLICY

A Return Material Authorization (RMA) is required prior to returning any product to Stellar Labs® under this warranty policy. Please call our Customer Service at (877) 626-3532 or send an email to [customerservice@mcmelectronics.com](mailto:customerservice@mcmelectronics.com) to obtain an RMA number. Enclose the product in a prepaid package and write the RMA number in large, clear numbers on the outside of the package. To avoid confusion or misunderstanding, a shipment(s) without an RMA number(s) or an unauthorized return(s) will be refused and returned to Customer freight collect.

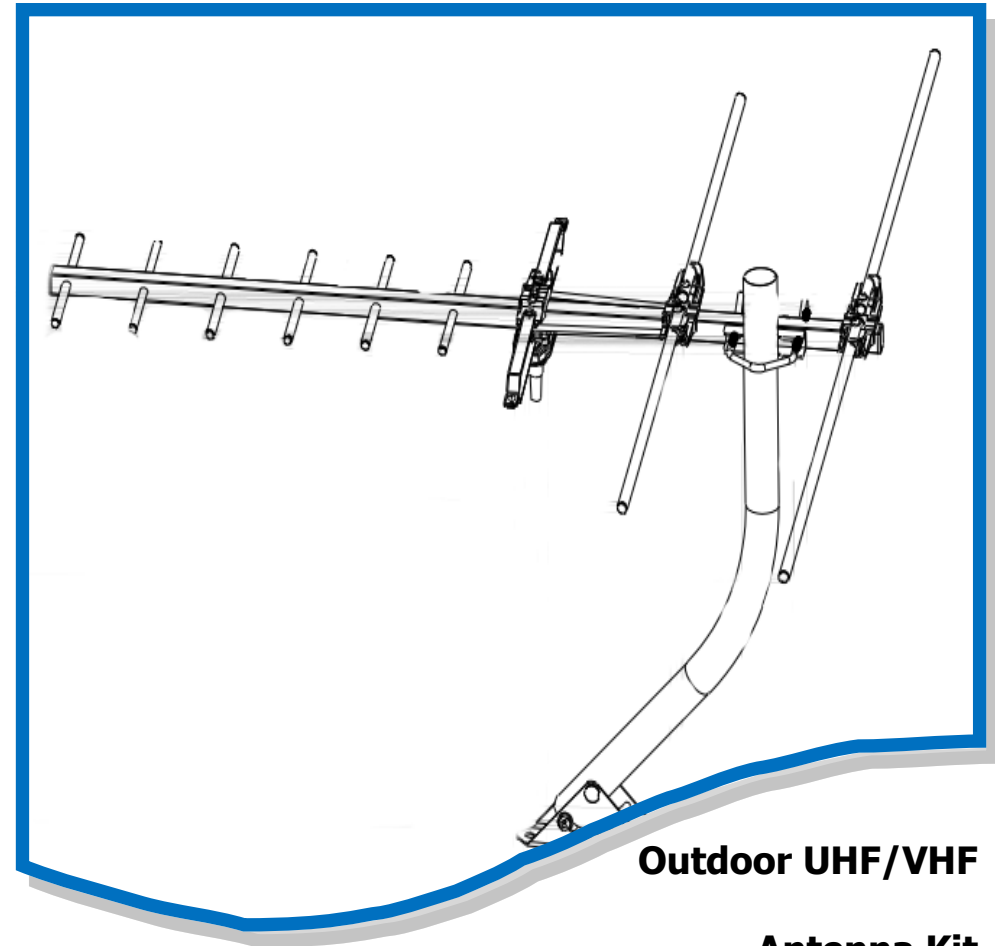

**Outdoor UHF/VHF**

**Antenna Kit**

# Safety Guidelines and Procedures

Listed below are extremely important safety guidelines that are to be followed when installing your Stellar Labs® antenna. Not following these guidelines can result in death or serious injury.

- Locate and take actions to avoid power lines and other wires in your work space.
- Do not climb onto a slick, icy, or wet roof.
- Avoid installations in high areas on windy days.
- Inspect the ladder you plan on using to ensure it is in safe operable condition.
- Do not position your ladder at an angle steeper than 70°.
- Do not climb on roofs that have curled or worn shingles. (Old shingles break easily or pull out.)
- Wear season-appropriate attire that is neither too loose or too tight. Always wear rubber-soled shoes with good grip.
- Wear a pair of durable gloves that also allow normal mobility of your hands.
- Look around your work area to observe for any potential dangers.
- Never climb onto a high location while alone.
- Avoid installing your antenna underneath tree branches or other overhanging objects.
- Antennas should be installed away from power lines and other wires a distance equal to at least two times the combined length of the mast and antenna.

## Grounding Procedure

### Mast Grounding

The NEC mandates that the antenna mast and mount be grounded directly. There can be no splices or connections in the ground wire between the mast and the grounding rod. First, attach one end of a No. 8 or No. 10 copper ground wire to the antenna mast. One of the bolts on the antenna mount can be used as a connection point. Masts that are painted or coated can have their coating scraped off on the area where they make contact to the mount. This will ensure a proper connection between the mast and the mount. Next, run the ground wire to the ground as directly as possible. Wire staples can be used to secure the ground wire against the side of a building. Avoid making right angle or sharper turns with the ground wire. Lightning has difficulty making such a turn and therefore may discharge into the building. Make ground wire turns as smooth and as slight as possible. The ground wire must be connected to a grounding rod. Water faucets and/or pipes are not acceptable. A copper-coated steel ground rod driven at least three feet into the ground is required. Special clamps that provide a solid connection between the ground wire and grounding rod should be used.

### Grounding the Signal Cable

TV Antennas and signal cable can accumulate static electrical charges that also increases the chances of lightning strike. To properly dissipate this static electricity, a grounding block should be used. The grounding block is connected to the signal cable at a point close to where the signal cable enters the building (a signal splitter that has a tab for ground on it will also work.) One end of a ground wire is attached to the grounding block. The other end of the wire is connected directly to the grounding rod. An antenna installation is not properly grounded unless both a mast ground and an grounding block are installed correctly.

# Assembly Instructions

1. Loosen the four Philips screws on the top of the unit that are holding the 4 long aluminum rods in place
2. Fold the aluminum rods so that they are perpendicular to the antenna body
3. Tighten the four Philips screws on the top of the unit so that the aluminum rods are in place and secured
4. Take the U-bolt and corresponding bracket, and put your J-pole between the two
5. Fit the bracket to the side of the antenna body and use the provided wing nuts on the opposite side to tighten and secure the antenna to the J-pole

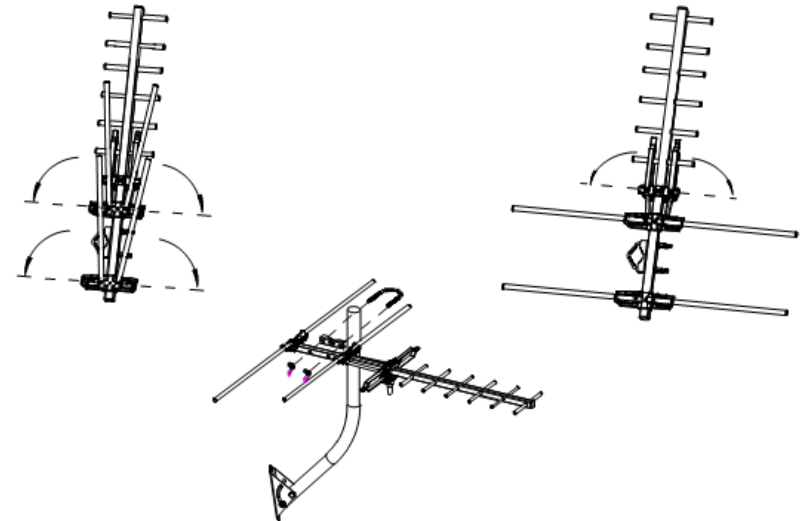

## Specifications

Frequency:	174~230MHz 470~862MHz
Channel:	5-12 21-69
Impedance:	75Ω
# of Elements:	9
Gain:	4-7dB 7.5-12dB
F-B Ratio:	7-12dB 10-16dB
Beam Width:	H 80° / V 90° H 50° / V 70°
Length:	31.9"