

(GB) Rechargeable LED work lamp 10 W

ML CA 110 M DE 4113

TECHNICAL SPECIFICATIONS:

Type description	ML CA 110 M DE 4113
Output:	10 W
Rechargeable batteries:	Li-Ion 3.7 V, 4400 mAh (cannot be replaced)
Operating time:	approx. 3 h (100 %) or 6 h (50 %)
Charging time:	depends on power supply unit, approx. 4.75 hours, at max. charging current 1 A
USB outlet:	5 V, max. 1 A
Protection class:	IP 54 (only if the transparent cover is closed)
Protection class:	III
Temperature range:	-10 °C – +40 °C

SAFETY NOTES:

- Please read the operating instructions carefully prior to use and do not throw them away.
- Prior to every use, check the lamp and power adapter for damage.
Never use the lamp or power adapter if there is any damage.
In this case, please contact an electrician or write to the service address provided by the manufacturer.

Non-compliance may result in risk to life due to electrical shock!

- Never open the device.
The lamp does not contain any components that require maintenance.
The LEDs cannot be replaced.
- Do not use the work lamp in explosive environments in which flammable liquids, gases or dusts are present. Risk to life!
- The lamp is protected against spray water.
Never immerse the lamp in water or other liquids.
Risk of explosion and fire!
- Keep children away from the lamp.
Children are unable to assess the dangers of electric current.
- Use only the recommended power supply unit to charge the batteries.
Using other power supply units can damage the batteries or result in an explosion!
- Switch the lamp off before you clean it. Clean the lamp regularly with a dry, lint-free cloth.
To remove dirt, a damp cloth can be used. Do not use any solvents, caustic cleaning agents, etc.
- Do not look directly at the light to avoid being blinded.

SET-UP/ MOUNTING THE LAMP:

Using the multi-level, folding bracket, the tilt angle of the lamp can be adjusted as needed. The lamp can be hung up on a hook using the bracket.

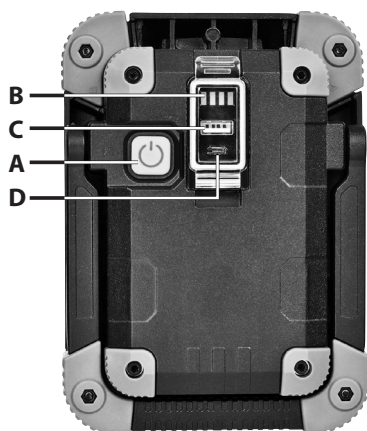
SWITCHING THE LAMP ON/OFF:

Press the button (A) to switch the lamp on.

The light will shine at 100% brightness. If the button is pressed again within 2 seconds, the lamp will switch to 50% mode. When selecting 50%, the service life of the lamp extends in comparison to the 100% setting as it consumes less energy.

Press the button again to switch the lamp off.

BATTERY LEVEL INDICATOR (B):

Displays the current charging status of the battery, or, how much energy is still available. If all 4 LEDs are lit, the battery is fully charged. If the battery is nearly empty, the LED blinks 5 times and the battery status indicator blinks continuously. Then the lamp will remain lit for approx. 5-10 minutes, before the deep discharge protection shuts the lamp off. This leaves enough time to finish working.

CHARGING UNITS WITH A USB CABLE (E.G. SMARTPHONES):

Suitable for products with a charging current of up to 1000 mA. To charge the unit with a USB cable, connect it to the USB charging port (C) under the transparent cover on the back of the unit. Close the cap after charging.

CHARGING THE BATTERY:

- To ensure optimum functionality, we recommend completely draining the integrated battery during the first use and the fully recharge it.
- The micro USB charging port (D) for charging the batter is under the transparent cap on the back of the unit. Connect the charging port to a conventional USB power supply unit, as used for smartphones, digital cameras, etc., using the provided USB cable. The charging time depends on the power supply unit and is, for instance, approx. 4.75 hours with a charging current of 1A.
- Use the battery level indicator (see description above) to determine the battery level. If all 4 LEDs are lit, the battery is fully charged.
- The lamp can be operated while charging, however, it has to be switched to 50% mode. The charging duration increases significantly in this operating mode.
- If the light is not used for an extended period of time the battery must be charged approximately every 3 months to ensure a long battery lifespan.
- After charging, make sure to close the charging port with the cap.

**Disposal****Do not dispose of electrical appliances with the household rubbish!**

In accordance with Directive 2012/19/EC on waste electrical and electronic equipment and the corresponding national law, used electrical equipment must be separated from the rubbish and reused or recycled in an environmentally responsible manner. Please contact your local authorities for available disposal options for your used device.

**Incorrect disposal of batteries and rechargeable batteries can harm the environment!**

Batteries and rechargeable batteries do not belong in the household waste.

They can contain poisonous heavy metals and are subject to treatment as hazardous wastes. Take your used batteries to a municipal collection site.

Manufacturer

Hugo Brennenstuhl GmbH & Co. KG
Seestraße 1 – 3 · D-72074 Tübingen

H. Brennenstuhl S.A.S.
4 rue de Bruxelles · F-67170 Bernolsheim

lectra-t ag
Blegistrasse 13 · CH-6340 Baar

Please visit the Service/FAQ section of our homepage, www.brennenstuhl.com, for more information.