

(GB) Operating Instructions **SMD LED Light**

ML DN 2806 S IP54 / ML DN 4006 S IP54 / L DN 2806 S IP54

Please note: Please read these instructions carefully prior to mounting the light and store them in a safe location afterwards!

TECHNICAL DATA:

Type of protection: IP 54
Protection class: I
Nominal voltage: 220 – 240 V~ 50/60 Hz
Operating temperature: -20°C – +40°C

Article:	Output:	Connection cable:	Dimensions (mm)	Weight:
ML DN 2806 S IP54	20 W	2 m H05RN-F 3G1.0	194 x 210 x 326.5	1800 g
ML DN 4006 S IP54	30 W	2 m H05RN-F 3G1.0	194 x 210 x 326.5	1800 g
L DN 2806 S IP54	20 W	3 m H05RN-F 3G1.0	194 x 80 x 194	1150 g

PROPER INTENDED USE:

This high-performance LED lamp is for lighting interior and exterior areas (e.g. workshops, camping, garage, household, etc.). The LED lamp is delivered, ready to connect, with a connection line and ground contact plug. All models are spray water-resistant.

Any other use than those described above or modifications to the device are not permitted.

OPERATION:

ML DN 2806 S IP54 / ML DN 4006 S IP54

Place on a dry, flat surface. The lamp can be switched on and off using the switch on the rear side.

L DN 2806 S IP54

The lamp can be installed on a suitable tripod. Make sure the tripod is sufficiently stable and the lamp is securely installed.

Installation height: <3 m.

SAFETY NOTES:

1. Prior to commissioning, make sure the right voltage is available.
2. Prior to each use, make sure the light and mains supply cable are not damaged in any way. Never use the lamp if you find damage.

Caution! A damaged light or mains supply cable pose a risk to life due to electric shock!

3. Do not use this light without properly attached gaskets!
4. Do not use the work lamp in explosive environments in which flammable liquids, gases or dusts are present. **Risk to life!**
5. LED lights are extremely bright. Do not look directly at the lamp.
6. Damaged protective covers must be replaced with an original Brennenstuhl® protective cover before the light can be used again.

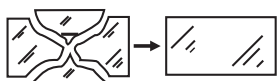

7. If the mains supply cable of the device is damaged it must be replaced by a qualified technician in order to avoid risks.
8. Make sure the light is attached firmly and securely. Make sure the cable is not crimped or otherwise damaged.
9. Keep children away from the lamp. Children cannot estimate the risk of electric shock.

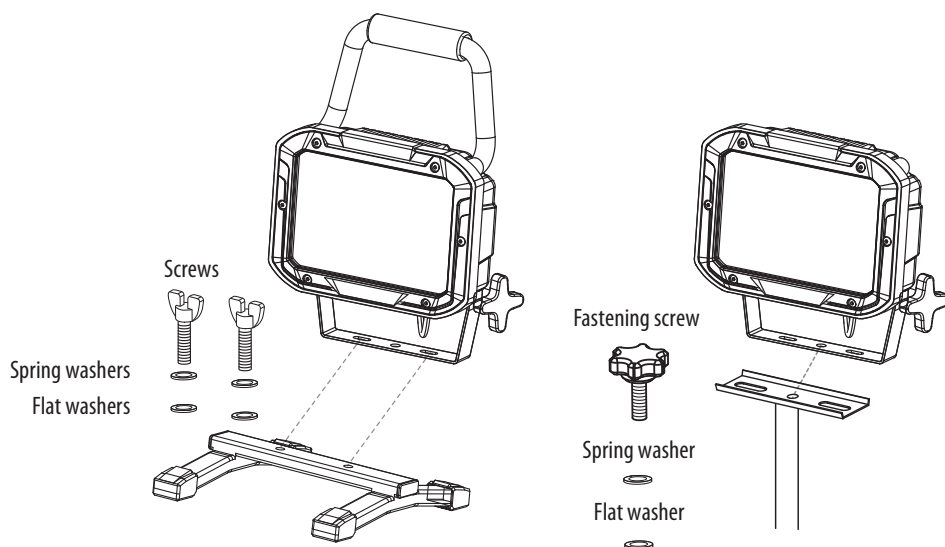

MAINTENANCE:

PLEASE NOTE: The LED light does not contain parts that need servicing.
The LED light source cannot be replaced. If necessary, replace the entire light.
Never open the lamp when the mains supply cable is connected.

Risk of life due to electric shock!

CLEANING:

Do not use solvents, corrosive cleaners or the like.
Use a dry or slightly moist cloth for cleaning only.

DISPOSAL:

Dispose of electrical devices in an environmentally responsible manner!

Do not dispose of electrical devices with household rubbish!

In accordance with European Directive 2012/19/EU regarding electrical and electronic devices must be collected separately and sent in for recycling.

Please contact your local authorities for available disposal options for your worn-out device.

Addresses

Hugo Brennenstuhl GmbH & Co. KG
Seestraße 1 – 3 · D-72074 Tübingen

H. Brennenstuhl S.A.S.
4 rue de Bruxelles · F-67170 Bernolsheim

lectra-t ag
Blegistrasse 13 · CH-6340 Baar

www.brennenstuhl.com