

CCB250 Series

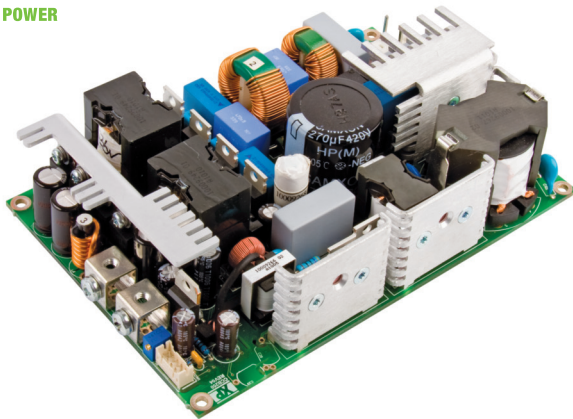

- 250 W Convection Cooled
- 300 W Peak Rating 500 ms
- Very High Efficiency up to 95%
- 1U Form Factor
- 5 V Standby Rail
- 80 V – 275 VAC Input Operation
- IT & Medical (BF) Safety Approvals
- Remote On/Off & Power Fail Signal as Standard

The CCB250 range of single output AC-DC 250 W nominal, 300 peak power supplies feature industry leading useable efficiency of 93% and absolute minimum efficiency of 90% with 90 VAC input and full load. This leap in efficiency has been achieved with full resonant ZCS topology and careful consideration to every aspect of power loss resulting in a convection cooled power supply packaged in a 6" (153mm) x 4" (102mm) x 1.5" (38mm) open frame design which can be easily installed into end applications due to a significant reduction in the dissipated heat, associated with other power supplies in this power range.

The six standard models cover the voltage range from 12V - 48V , have dual input fusing and are compliant with IEC60601-1 Medical (BF) and IEC60950-1 IT safety approvals.

The CCB250 series also boasts low earth leakage current of typically 60 μ A at 115V and 110 μ A at 230V, class B conducted emissions, 5V standby rail, power fail signal and remote on / off.

Models and Ratings - Convection-cooled

Output Power		Output Voltage V1	Output Current V1		Standby Supply	Model Number
P nom	P peak ⁽¹⁾		I nom	I peak ⁽¹⁾		
250 W	300 W	12.0 VDC	20.8 A	25 A	5.0 V/0.5 A	CCB250PS12
250 W	300 W	15.0 VDC	16.7 A	20 A	5.0 V/0.5 A	CCB250PS15
250 W	300 W	24.0 VDC	10.4 A	12.5 A	5.0 V/0.5 A	CCB250PS24
250 W	300 W	28.0 VDC	8.9 A	10.7 A	5.0 V/0.5 A	CCB250PS28
250 W	300 W	36.0 VDC	6.9 A	8.3 A	5.0 V/0.5 A	CCB250PS36
250 W	300 W	48.0 VDC	5.2 A	6.25 A	5.0 V/0.5 A	CCB250PS48

Notes:

1. Peak duration is 500 ms max, average power must not exceed 250 W.

Input Characteristics

Characteristic	Minimum	Typical	Maximum	Units	Notes & Conditions
Input Voltage - Operating	80	115/230	275	VAC	Derate output power <90 VAC. See fig 1. Power fail signal cannot be used <90 VAC.
Input Frequency	47	50/60	63	Hz	
Power Factor		>0.9			EN61000-3-2 class A compliant
Input Current - No Load		0.13/0.17		A	115/230 VAC
Input Current - Full Load		2.4/1.2		A	115/230 VAC
Inrush Current			30	A	230 VAC, 25 °C
Earth Leakage Current		60/110	250	µA	115/230 VAC/50 Hz (Typ.), 264 VAC/60 Hz (Max.)
Input Protection	T5.0A/250 V internal fuse in both line and neutral				

Output Characteristics

Characteristic	Minimum	Typical	Maximum	Units	Notes & Conditions
Output Voltage - V1	12		48	VDC	See Models and Ratings table
Initial Set Accuracy			±0.5 ^(v1) , ±5 ^(v2)	%	50% load, 115/230 VAC
Output Voltage Adjustment	±3			%	V1 only via potentiometer. See mech. details (page 11).
Minimum Load	0			A	
Start Up Delay		0.5		s	230 VAC full load (see fig.2)
Hold Up Time	16			ms	90 VAC full load (see fig.3)
Drift			±0.2	%	After 20 min warm up
Line Regulation			±0.5	%	90-264 VAC
Load Regulation			±1 ^(v1) , ±5 ^(v2)	%	0-100% load.
Transient Response - V1			4	%	Recovery within 1% in less than 500 µs for a 50-75% and 75-50% load step
Over/Undershoot - V1			5	%	
Ripple & Noise			1 ^(v1) , 2 ^(v2)	% pk-pk	20 MHz bandwidth (see fig.4 & 5)
Overvoltage Protection	115		140	%	Vnom DC. Output 1 only, recycle input to reset
Overload Protection	125		165	% I nom	Output 1 only, auto reset (see fig.6)
Short Circuit Protection					Continuous, trip & restart (hiccup mode) all outputs
Temperature Coefficient			0.05	%/°C	
Overtemperature Protection		110		°C	Auto recovery - temperature of main transformer
Patient Leakage Current			100	µA	264 VAC/60 Hz

Input Voltage Derating

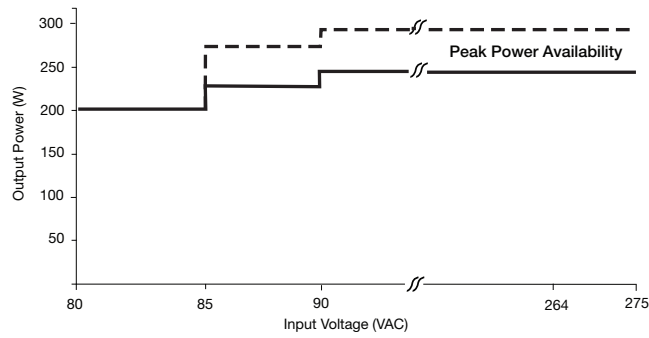

Figure. 1

Start Up Delay From AC Turn On

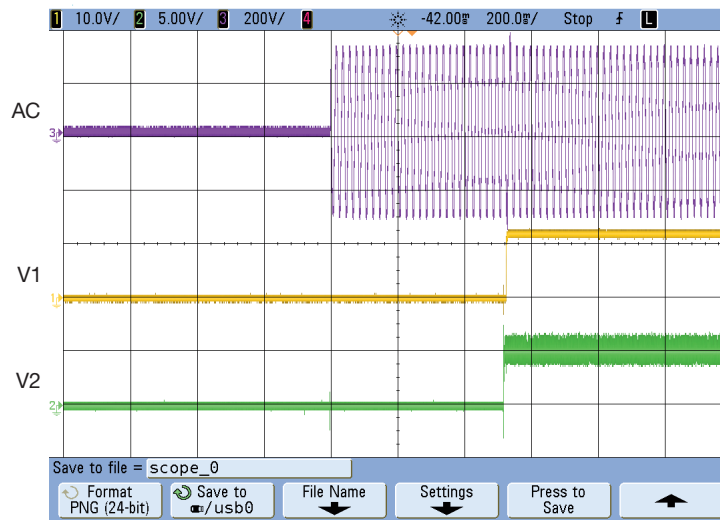

Figure. 2
V1 & V2 start up example
from AC turn on (580 ms)

Hold Up Time From Loss of AC



Figure 3
V1 hold up example at 250 W load
with 90 VAC input (42 ms)

Output Ripple & Noise

Figure 4
V1 CCB250PS12 (full load)
45 mV pk-pk ripple. 20 MHz BW

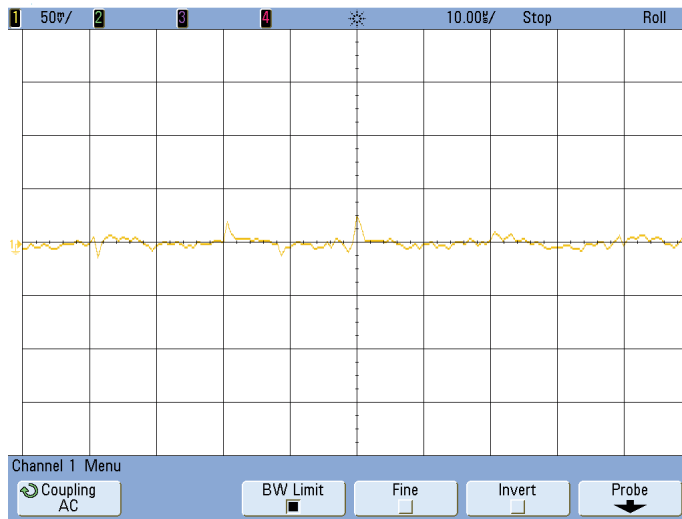
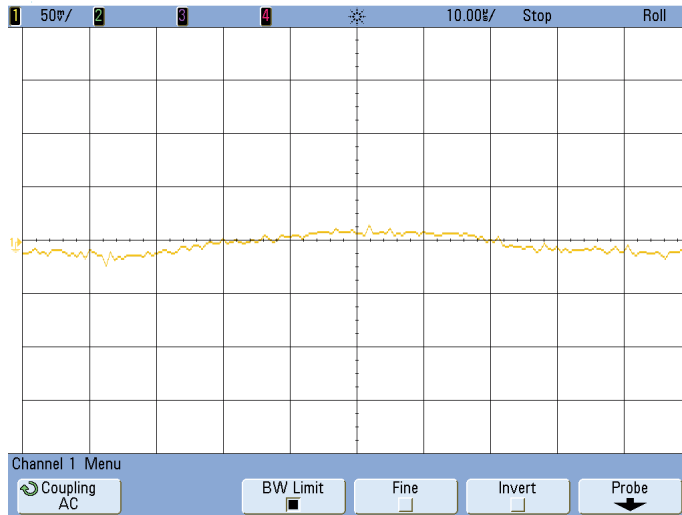
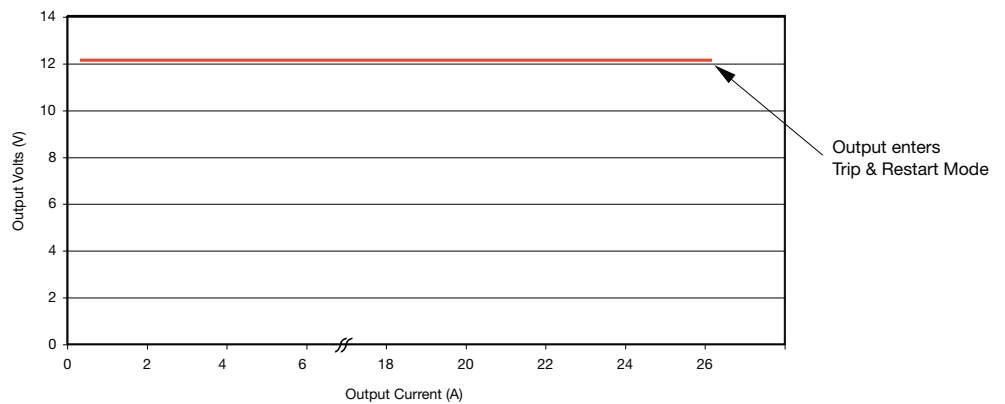

Figure 5
V1 CCB250PS24 (full load)
50 mV pk-pk ripple. 20 MHz BW



Output Overload Characteristic

Figure 6
Typical V1 Overload
Characteristic
(CCB250PS12 shown)



General Specifications

Characteristic	Minimum	Typical	Maximum	Units	Notes & Conditions
Efficiency		93		%	Full load (see fig.7 & 8)
Isolation: Input to Output Input to Ground Output to Ground	4000			VAC	
	1500			VAC	
	1500			VAC	
Switching Frequency		30-500 / 25.6 / 51.2		kHz	PFC / Boost / Main Converter.
Power Density			6.9	W/in ³	
Mean Time Between Failure		369		kHrs	MIL-HDBK-217F, Notice 2 +25 °C GB
Weight		1.2 (550)		lb (g)	

Efficiency Versus Load

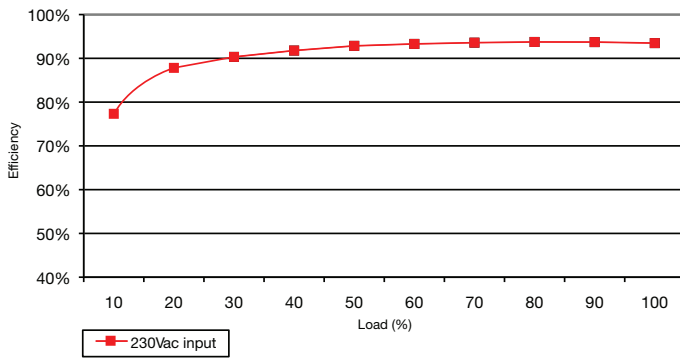

Figure 7
CCB250PS12

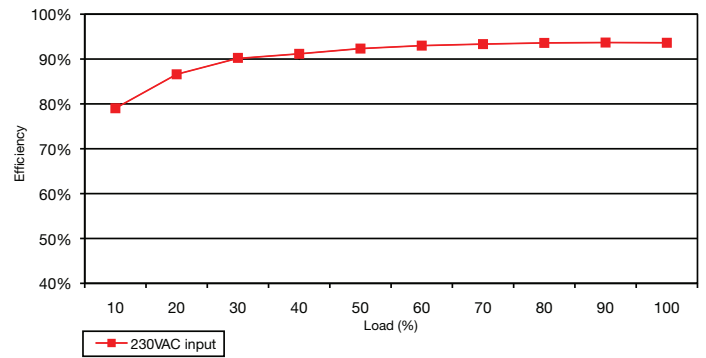

Figure 8
CCB250PS24

Power Loss

Waste heat creates a big headache for system designers. The industry leading efficiency achieved by the CCB250 is 5-10% above existing topologies used in this power area. This can result in a 60% reduction in generated heat as shown below and enables the overall system to run much cooler and more reliably.

Example 1

	Conventional Products	CCB250
Efficiency	85 %	93 %
Generated Heat	44.1 W	18.8 W
% Losses	100 %	42 %

Example 2

	Conventional Products	CCB250
Efficiency	90 %	93 %
Generated Heat	27.8 W	18.8 W
% Losses	100 %	67 %

Characteristic	Notes & Conditions
Signals	
Power Fail	Uncommitted opto isolated transistor, normally off when AC is good (see fig.9 - 11) Provides ≥ 5 ms (typically 20-30ms) warning of loss of output from AC failure
Remote On/Off (Inhibit/Enable)	Uncommitted isolated optocoupler diode, powered diode inhibits the supply (see fig.12-17)
Standby Supply V2	Isolated 5 V/0.5 A supply, always present when AC supplied.

Signals

Power Fail

Figure 9

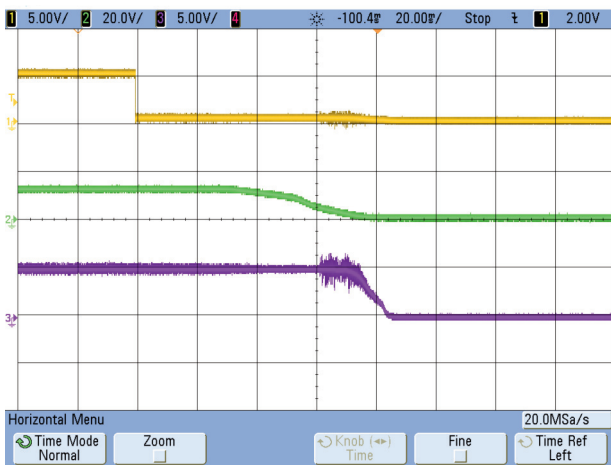
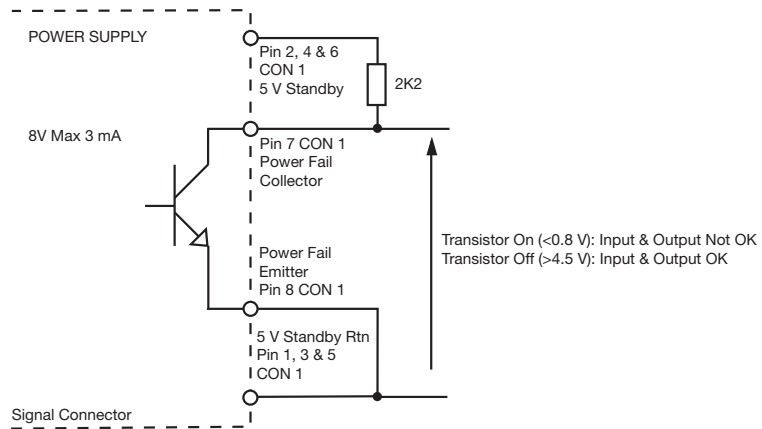

Figure 10
Power Fail signal example at AC switch off

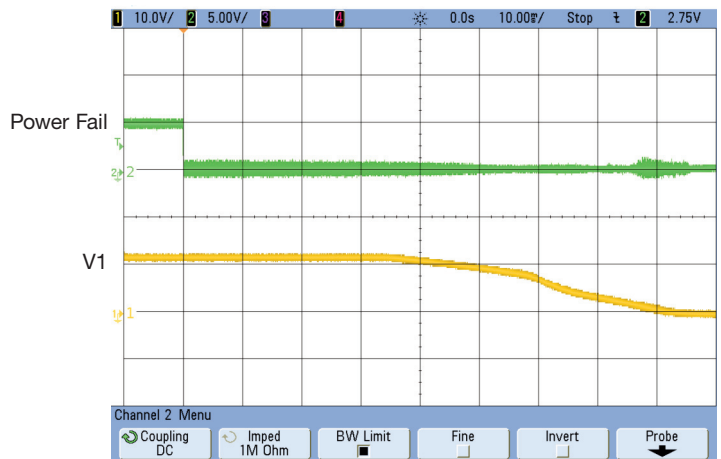

Figure 11
V1 warning time example at Power Fail signal 230 VAC
250 W load (37 ms)

Signals

Remote On/Off (Inhibit/Enable)

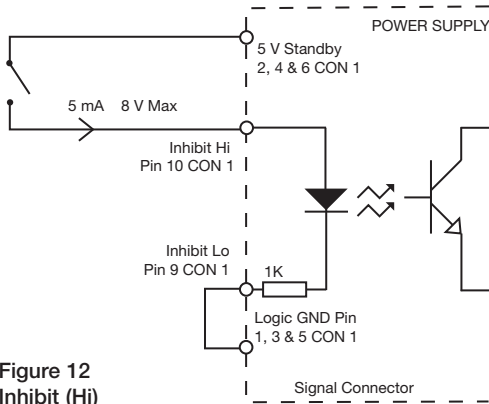

Figure 12
Inhibit (Hi)

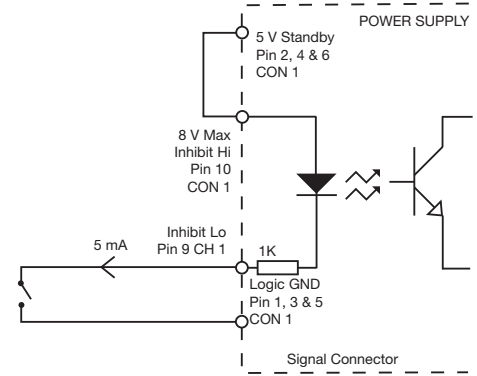

Figure 13
Inhibit (Lo)

Figure 14
Example of outputs switching off when Inhibit (Lo) configuration used & switch closed

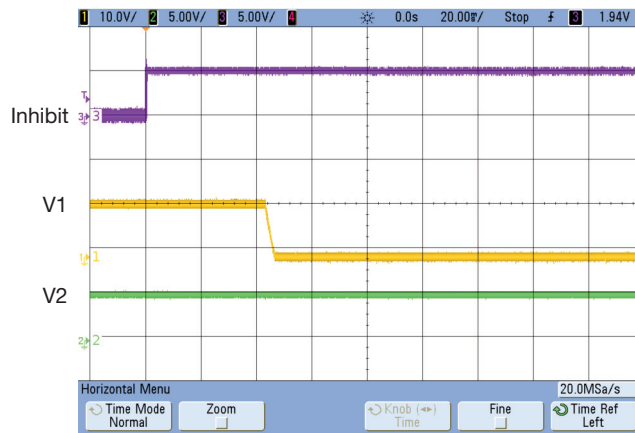
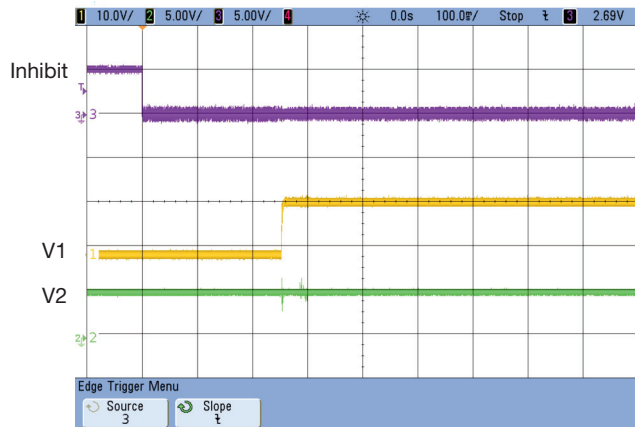

Figure 15
Example of outputs switching on when Inhibit (Lo) configuration used & switch open



Signals

Remote On/Off (Inhibit/Enable)

Figure 16
Enable (Hi)

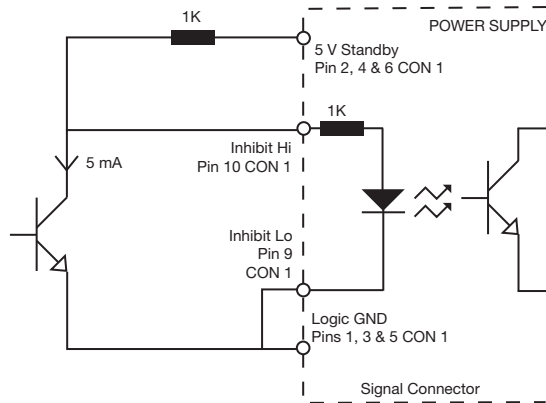
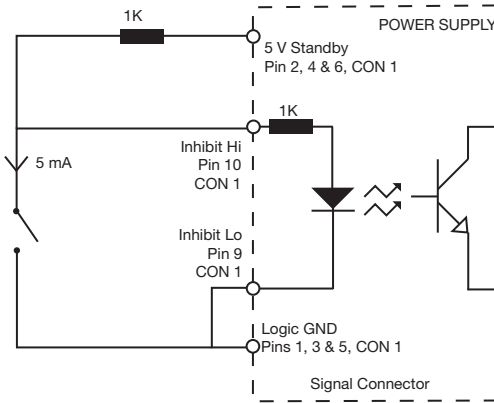

Figure 17
Enable (Lo)



Notes

1. At AC switch on the output (V) may momentarily rise when the unit is disabled using the 5V standby in conjunction with the Remote On/Off function.

Environmental

Characteristic	Minimum	Typical	Maximum	Units	Notes & Conditions
Operating Temperature	-20 (-40)		+70	°C	Derate linearly from +50 °C at 2.5%/°C to 50% at 70 °C. See fig.18 & Thermal Considerations, p.11. (-40 °C consult sales)
Warm up Temperature		20		Minutes	
Storage Temperature	-40		+85	°C	
Cooling					Convection cooled. See fig.18 & Thermal Considerations, p.11.
Humidity	5		95	%RH	Non-condensing
Operating Altitude			3000	m	
Shock					3 x 30 g/11 ms shocks in both +ve & -ve directions along the 3 orthogonal axis, total 18 shocks.
Vibration					Single axis 10-500 Hz at 2 g x 10 sweeps

Derating Curve

Figure 18

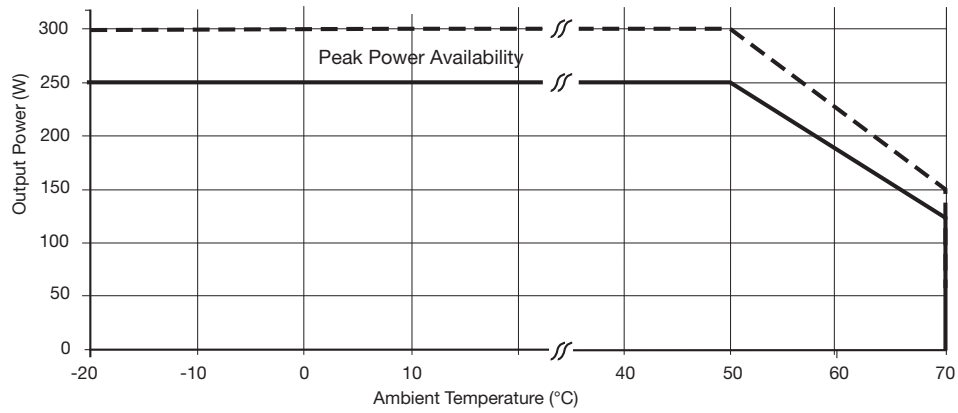

Electromagnetic Compatibility - Immunity

Phenomenon	Standard	Test Level	Criteria	Notes & Conditions	
Low Voltage PSU EMC	EN61204-3	High severity level	as below		
Harmonic Current	EN61000-3-2	Class A			
Radiated	EN61000-4-3	3	A		
EFT	EN61000-4-4	3	A		
Surges	EN61000-4-5	Installation class 3	A		
Conducted	EN61000-4-6	3	A		
Dips and Interruptions	EN61000-4-11	Dip: 30% 10 ms	A		
		Dip: 60% 100 ms	B		
		Dip: 100% 5000 ms	B		
	EN60601-1-2 (EN61000-4-11)	Dip: 30% 500 ms	A		
		Dip: 60% 100 ms	A	Requires load derating to approx 80% with 115VAC input.	
		Dip: 100% 10 ms	A		
		Int.: >95% 5000 ms	B		

Electromagnetic Compatibility - Emissions

Phenomenon	Standard	Test Level	Criteria	Notes & Conditions
Conducted	EN55022	Class B		See fig. 19
Radiated	EN55022	Class A		
Voltage Fluctuations	EN61000-3-3			

Typical EMC Plot

Figure 19 - Typical conducted noise plot

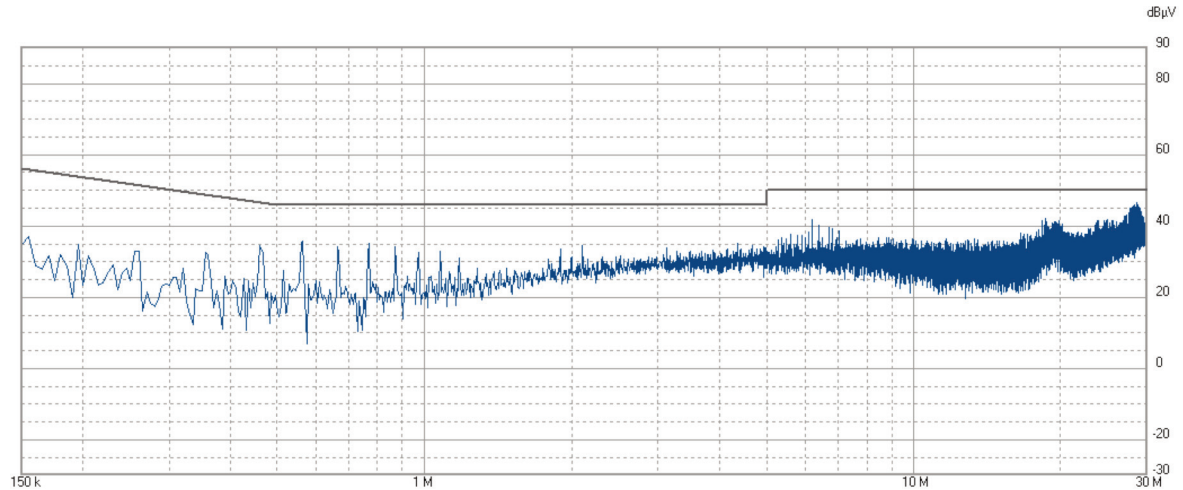

Safety Agency Approvals

Safety Agency	Safety Standard	Category
CB Report	Certificate # US/17818/UL IEC60950-1:2005 Ed 2	Information Technology
UL	UL File #E139109-A62-UL UL60950-1 (2007), CSA 22.2 No.60950-1-07 Ed 2	Information Technology
TUV	TUV Certificate # B11 10 57396 113, EN60950-1:2010	Information Technology
CE	LVD	

Safety Agency	Safety Standard	Category
CB Report	Certificate #US/18197/UL, IEC60601-1 Ed 3 Including Risk Management	Medical
UL	UL File # E146893, ANSI/AAMI ES 60601-1:2005 & CSA C22.2 No. 60601-1:08	Medical
TUV	TUV Certificate # B11 12 57396 124, EN60601-1:2006	Medical

Means of Protection		Category
Primary to Secondary	2 x MOPP (Means of Patient Protection)	IEC60601-1 Ed 3
Primary to Earth	1 x MOPP (Means of Patient Protection)	
Secondary to Earth	1 x MOPP (Means of Patient Protection)	

Equipment Protection Class	Safety Standard	Notes & Conditions
Class I & BF	IEC60950-1:2005 Ed 2 & IEC60601-1 Ed 3	See safety agency conditions of acceptability for details

Mechanical Details

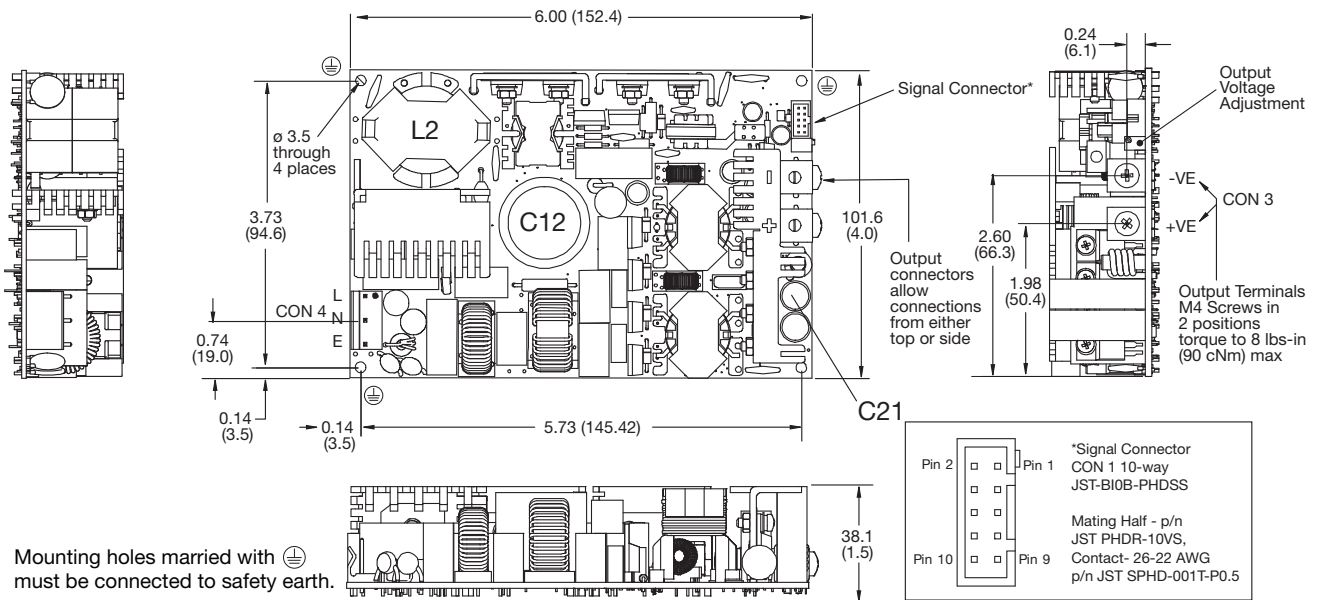

Notes
 1. All dimensions in inches (mm).
 Tolerance .xx = ± 0.02 (0.50); .xxx = ± 0.01 (0.25)

Weight 1.2 lb (550 g) approx

Input Connector CON 4	
Pin 1	Line
Pin 2	Neutral
Pin 3	Earth

CON 4 mates with Molex housing 09-50-1051 and Molex series 5194 crimp terminals.

Output Connector CON 3	
1	+V1
2	V 1 RTN

Signals Connector CON 1	
1	5 V Standby Return
2	5 V Standby
3	5 V Standby Return
4	5 V Standby
5	5 V Standby Return
6	5 V Standby
7	Power Fail (Collector)
8	Power Fail (Emitter)
9	Remote On / Off (Cathode)
10	Remote On / Off (Anode)

CON 1 mates with JST housing PHDR-10VS with contact SPHD-001T-P0.5

Thermal Considerations

In order to ensure safe operation of the PSU in the end-use equipment, the temperature of the components listed in the table below must not be exceeded. Temperature should be monitored using K type thermocouples placed on the hottest part of the component (out of any direct air flow). See Mechanical Details for component locations.

Temperature Measurements (Ambient $\leq 50\text{ }^{\circ}\text{C}$)	
Component	Max Temperature $^{\circ}\text{C}$
L2	120 $^{\circ}\text{C}$
C12	105 $^{\circ}\text{C}$
C21	105 $^{\circ}\text{C}$

Service Life

The estimated service life of the CCB250 Series is determined by the cooling arrangements and load conditions experienced in the end application. Due to the uncertain nature of the end application this estimated service life is based on the actual measured temperature of a key capacitor within the product when installed in the end application.

The graph below expresses the estimated lifetime for a given component temperature and assumes continuous operation at this temperature.

Estimated Service Life vs Component Temperature

Figure 20

