

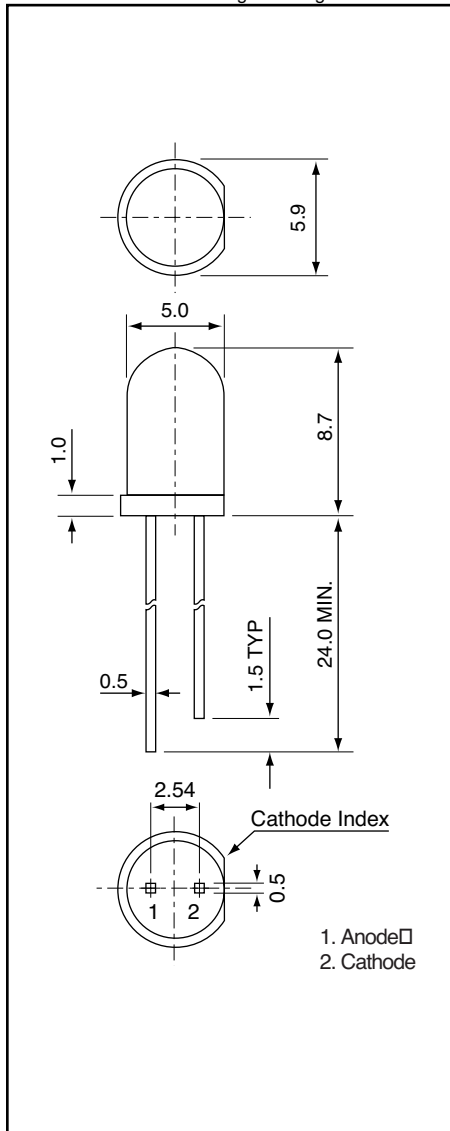

Weight: 0.30 g Unit: mm



Product specifications contained herein may be changed without prior notice. It is therefore advisable to contact Purdy Electronics before proceeding with the design of equipment incorporating this product.

AND181YP

Standard LED

T-1 3/4 Package (5 mm)

Features

- Low power requirement
 - Flush-mount
 - All plastic molded lens
 - Color: GaAsP–Yellow
- RoHS Compliant

Optical Characteristics (T_a = 25°C)

Color		Lens Desc.	Axial Luminous Intensity (mcd)		Test Condition (I _F –mA)	Viewing Angle 2θ1/2 (deg)
LED	Lens		Min.	Typ.		
Yellow	Lt Yellow	Clear	75	150	20	15

Absolute Maximum Ratings (T_a = 25°C)

Characteristics	Symbol	Rating (Yellow)	Unit
Forward Current (DC)	I _F	30	mA
Reverse Voltage	V _R	4	V
Power Dissipation	P _D	75	mW
Operating Temperature	T _{Opr}	-25 to +85	°C
Storage Temperature Range	T _{Stg}	-25 to +100	°C

Electro-Optical Characteristics (T_a = 25°C)

Characteristics	Symbol	Test Condition	Yellow			Unit
			Min.	Typ.	Max.	
Forward Voltage	V _F	I _F = 20mA	–	2.1	3.0	V
Reverse Current	I _R	V _R = 4 V	–	–	100	μA
Peak Emission Wavelength	λ _p	I _F = 15mA	–	585	–	nm
Spectral Line Half Width	λ	I _F = 15mA	–	32	–	nm

Precaution

Please be careful of the following:

1. Soldering temperature: 260°C max; Soldering time: 5 sec. max; Soldering portion of lead: up to 1.6 mm from the body of the device.
2. The lead can be formed up to 5 mm from the body of the device without forming stress. Soldering should be performed after the lead forming.

