



## Product Change Notification – 2017/11

Product Line:	etherCON Chassis Connector	Part No:	NE8FDX-*6-W
Piece Part:	Sealing gasket	Part No:	91226311 BG 8801035
Engineering Change Notification:	46/2017	Date:	07.07.2017
Comments:	Modified sealing gasket with additional fastening washers.		
Affected products:	<ul style="list-style-type: none"><li>• NE8FDX-P6-W</li><li>• NE8FDX-Y6-W</li></ul>		
First Shipment of Modified Product:	K31		

### Engineering Change Notice

To improve and simplify the fastening of the gasket sealing, the diameter of the sealing screwholes is reduced. Additionally 4 conical washers are added.

The combination of modified sealing gasket and conical washer assures a proper fitment.

Please check and follow carefully the assembly instruction.





# ASSEMBLY INSTRUCTION

## etherCON | CAT6A Chassis Connector NE8FDX-P6-W with rubber sealing - IP65

### ASSEMBLY

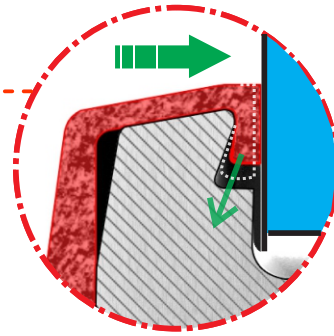
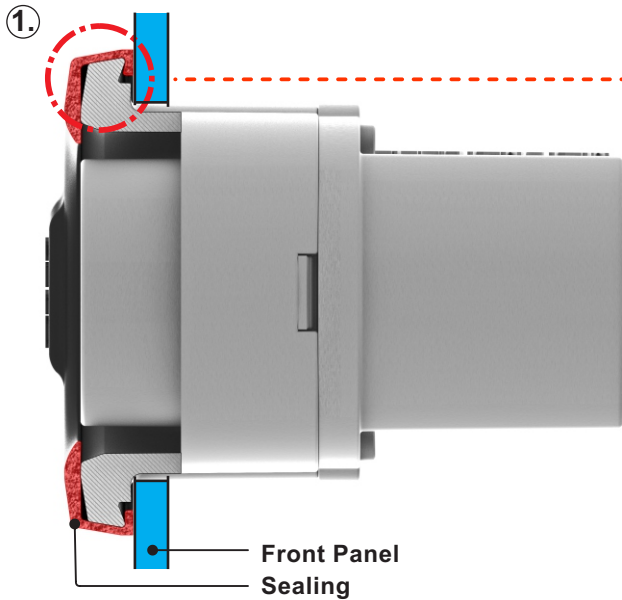

Flange shape ensures proper sealing.

#### ATTENTION:

- ① Sealing must be positioned well
- ② Position the supplied washers
- ③ Diameter of countersunk screw head min. 5.0 mm and max. 6.0 mm\*
- ④ Maximum allowable torque 0.4 Nm

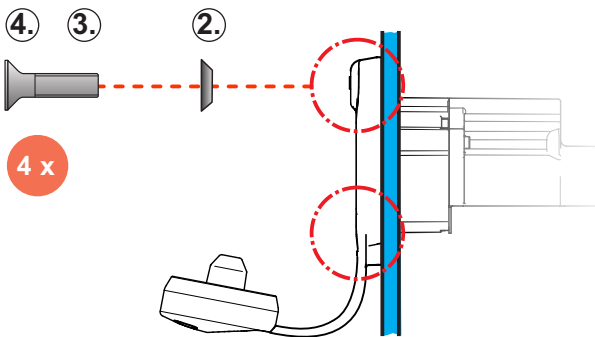

### Panel Cutout (Rear Side)

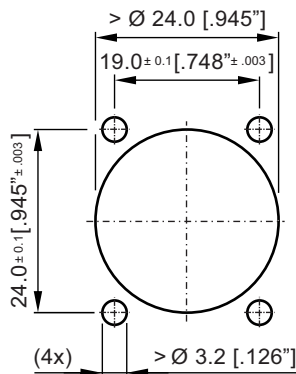

### \*Countersunk screw

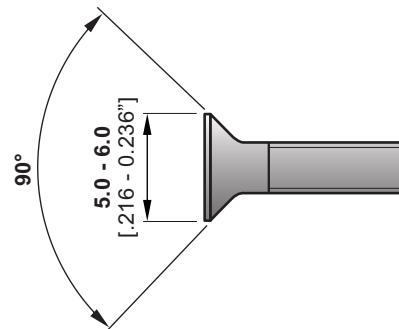

NEUTRIK AG	LI	T: +423/237 24 24	F: +423/232 53 93	NEUTRIK France	FR	T: +33 1/4131 6750	F: +33 1/4131 0511
NEUTRIK USA Inc.	USA	T: +1 704/972 3050	F: +1 704/438 9202	NEUTRIK Tokyo Ltd.	JP	T: +81 3/3663 4733	F: +81 3/3663 4796
NEUTRIK (UK) Ltd.	UK	T: +44 1983/811 441	F: +44 1983/811 439	NEUTRIK Hong Kong Ltd.	HK	T: +852/2687 6055	F: +852/2687 6052
NEUTRIK Vertriebs GmbH	DE/NL/AT/DK	T: +49 8131/280 890	F: +49 8131/280 830	NEUTRIK India Pvt. Ltd.	IND	T: +91/982 05 43 424	F: +91/22 26163 540

Draft. Nr.: BDA 442-2 | Update: 23.08.2017 | Data subject to change without prior notice. ©2017 NEUTRIK®. ALL RIGHTS RESERVED. NEUTRIK® is a registered trademark.