

# swissbit®

Product Data Sheet

## Industrial mSATA SSD (M0-300 Full Size)

### X-60m Series

SATA III - 6.0 Gbit/s

Standard and Industrial  
Temperature Grade



# Contents

<b>1. PRODUCT SUMMARY .....</b>	<b>3</b>
<b>2. PRODUCT FEATURES .....</b>	<b>4</b>
<b>3. ORDERING INFORMATION .....</b>	<b>5</b>
<b>4. PRODUCT DESCRIPTION .....</b>	<b>6</b>
4.1 PERFORMANCE SPECIFICATIONS .....	7
4.2 CURRENT CONSUMPTION .....	7
4.3 ENVIRONMENTAL SPECIFICATIONS .....	8
4.4 REGULATORY COMPLIANCE .....	9
4.5 MECHANICAL SPECIFICATIONS .....	9
4.6 RELIABILITY AND ENDURANCE .....	10
4.7 DRIVE GEOMETRY SPECIFICATION .....	10
<b>5. ELECTRICAL INTERFACE .....</b>	<b>11</b>
<b>6. PACKAGE MECHANICAL .....</b>	<b>12</b>
<b>7. ATA COMMANDS .....</b>	<b>13</b>
<b>8. IDENTIFY DEVICE INFORMATION .....</b>	<b>15</b>
<b>9. S.M.A.R.T. FUNCTIONALITY .....</b>	<b>16</b>
9.1 S.M.A.R.T. SUBCOMMANDS .....	16
9.2 S.M.A.R.T. READ DATA .....	17
9.3 S.M.A.R.T. ATTRIBUTES .....	17
9.4 S.M.A.R.T. ATTRIBUTE ENTRY STRUCTURE .....	18
<b>10. PART NUMBER DECODER .....</b>	<b>19</b>
10.1 MANUFACTURER .....	19
10.2 MEMORY TYPE .....	19
10.3 PRODUCT TYPE .....	19
10.4 DENSITY .....	19
10.5 PLATFORM .....	19
10.6 PRODUCT GENERATION .....	19
10.7 MEMORY ORGANIZATION .....	19
10.8 TECHNOLOGY .....	19
10.9 NUMBER OF FLASH CHIPS .....	19
10.10 FLASH CODE .....	20
10.11 TEMPERATURE OPTION .....	20
10.12 DIE CLASSIFICATION .....	20
10.13 PIN MODE .....	20
10.14 DRIVE CONFIGURATION XYZ .....	20
10.15 OPTION .....	20
<b>11. SWISSBIT MSATA SSD MARKING SPECIFICATION .....</b>	<b>21</b>
11.1 TOP VIEW .....	21
11.2 LABEL CONTENT .....	21
<b>12. REVISION HISTORY .....</b>	<b>22</b>

# X-60m Series – Industrial mSATA Solid State Drive 8 GBytes Up to 480 GBytes (M0-300A)

## 1. Product Summary

- **Capacities:** 8 GBytes, 16 GBytes, 30 GBytes, 60 GBytes, 120 GBytes, 240 GBytes, 480 GBytes
- **Form Factor:**
  - JEDEC M0-300A Sized Solid State Drive (50.8 mm x 29.85 mm x 3.5 mm)
  - 52-Pin PCI Express (PCIe) Mini-Connector (SATA III)
- **Compliance:** SATA Rev 3.1 – 6 Gbit/s (3 Gbit/s and 1.5 Gbit/s backward compatible)
- **Command Sets:** Supports ATA/ATAPI-8 and ACS-2 (2011/06/22)
- **Performance:**
  - Burst Transfer Rate: Up to 600 MBytes/s in SATA III – 6.0 Gbit/s
  - Read Performance: Sequential Read up to 520 MBytes/s, Random Read IOPs up to 75,000
  - Write Performance: Sequential Write up to 450 MBytes/s, Random Write IOPs up to 75,000
- **Operating Temperature Range<sup>1</sup>:**
  - Commercial: 0 °C to 70 °C
  - Industrial: -40 °C to 85 °C
- **Storage Temperature Range:** -40 °C to 85 °C
- **Operating Voltage:** 3.3 V ± 5%
- **Power (Max Capacity):**
  - Read (Active): 1.5 W
  - Write (Active): 3.2 W
  - Idle: 380 mW
  - Slumber: 115 mW
- **Data Retention:** 10 Years @ Life Begin; 1 Year @ Life End
- **Endurance:** TeraBytes Written (TBW) @ Max Capacity<sup>2</sup>
  - Client > 975
  - Embedded > 280
  - Enterprise > 235
- **Shock/Vibration:** 1,500 *g*/20 *g* (MIL-STD810)
- **High-Performance 32-Bit Processor with Integrated, Parallel Flash Interface Engines:**
  - Multi-Level Cell (MLC) NAND Flash
  - Hardware BCH Code ECC (up to 66 bit correction per 1 KByte page)
- **High Reliability:**
  - Mean Time Between Failure (MTBF): > 2,000,000 hours
  - Data Reliability: < 1 non-recoverable error per 10<sup>16</sup> bits read

<sup>1</sup> Adequate airflow is required to ensure the drive temperature, as reported in the S.M.A.R.T. data, does not exceed the specified maximum operating temperature.

<sup>2</sup> According to JEDEC (JESD471), the time to write the full TBW is 18 months. Higher average daily data volume reduces the specified TBW.

## 2. Product Features

- Best-in-Class Performance and Endurance with **durabit™** Technology
- Dynamic and Static Wear Leveling
- Page Mode Flash Translation Layer (FTL)
- Data Care Management
  - Active: Adaptive Read Refresh
  - Passive: Background Media Scan
- Lifetime Enhancements
  - Dynamic Bad Block Remapping
  - Write Amplification Reduction
- On-Board Power Fail Protection
- AHCI, TRIM, and NCQ Support
- ATA Security Feature Set Support
- DEVSLP Compatible
- In-Field Firmware Update
- Enterprise-Grade Self-Monitoring, Analysis, and Reporting Technology (S.M.A.R.T.)
- 30 µinch Gold-Plated Connector (IPC-6012B Class 2 Compliant)
- Life Cycle Management
- Controlled "Locked" BOM
- RoHS-6 Compliant
- AES256 Encryption (on request)
- Swissbit Life Time Monitoring (SBLTM) Tool and SDK for SBLTM (on request)



### 3. Ordering Information

**Table 1: Standard Product List**

Capacity	Part Number
8 GBytes	SFSA008GUxAA1T0-t-GS-2y6-STD
16 GBytes	SFSA016GUxAA2T0-t-GS-2y6-STD
30 GBytes	SFSA030GUxAA1T0-t-LB-2y6-STD
60 GBytes	SFSA060GUxAA2T0-t-LB-2y6-STD
120 GBytes	SFSA120GUxAA4T0-t-LB-2y6-STD
240 GBytes	SFSA240GUxAA4T0-t-HC-2y6-STD
480 GBytes	SFSA480GUxAA4T0-t-OC-2y6-STD

x = product generation; t = temperature; y= firmware revision

**Table 2: Part Numbers Available for Ordering**

Capacity	Commercial Temperature	Industrial Temperature
	Part Number	Part Number
8 GBytes	SFSA008GU2AA1T0-C-GS-216-STD	SFSA008GU2AA1T0-I-GS-216-STD
16 GBytes	SFSA016GU2AA2T0-C-GS-216-STD	SFSA016GU2AA2T0-I-GS-216-STD
30 GBytes	SFSA030GU2AA1T0-C-LB-216-STD	SFSA030GU2AA1T0-I-LB-216-STD
60 GBytes	SFSA060GU2AA2T0-C-LB-216-STD	SFSA060GU2AA2T0-I-LB-216-STD
120 GBytes	SFSA120GU2AA4T0-C-LB-216-STD	SFSA120GU2AA4T0-I-LB-216-STD
240 GBytes	SFSA240GU2AA4T0-C-HC-216-STD	SFSA240GU2AA4T0-I-HC-216-STD
480 GBytes	SFSA480GU2AA4T0-C-OC-216-STD	SFSA480GU2AA4T0-I-OC-216-STD

## 4. Product Description

The Swissbit® X-60m Solid State Drive (SSD) leverages the JEDEC M0-300A industry-standard form factor and connectivity. Combined with a SATA Gen III controller and Multi-Level Cell (MLC) NAND flash technology, the X-60m realizes a robust non-volatile storage solution for today's embedded computing applications. A functional block diagram of the X-60m SSD is provided below in Figure 1.

Figure 1: X-60m mSATA Functional Block Diagram

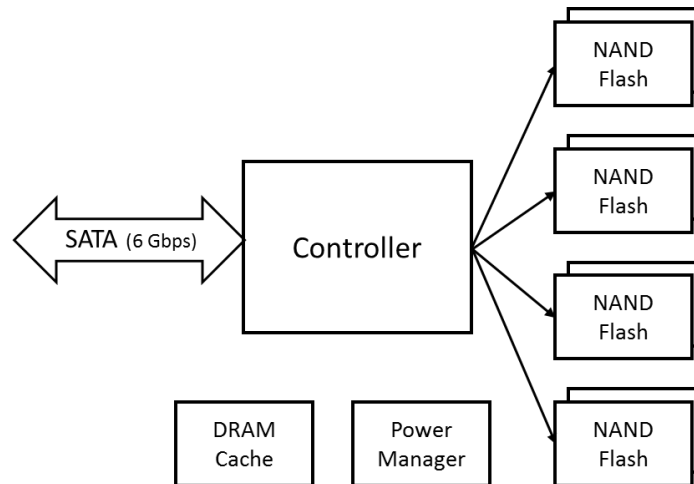

The X-60m SSD incorporates a 52-pin edge type connector set to support host read/write, control, and power activity per the applicable JEDEC and SATA IO Specifications<sup>3</sup>. In addition, the X-60m SSD host interface pins include 30 µinch gold plating to meet or exceed industrial and NetCom industry subsystem compliance requirements. Mechanical robustness is assured with two 2.6 mm (diameter) JEDEC-compliant mounting holes located at the opposite end of the drive assembly to secure the X-60m SSD to the host platform, in even the most extreme operating environments.

The on-board SATA III controller manages the interface between the host and the non-volatile NAND flash memory array. The controller supports SATA Gen III (6 Gbit/s) interface speeds and is fully backward compatible with SATA Gen II (3 Gbit/s) and SATA Gen I (1.5 Gbit/s) to enable the broadest possible range of platform compatibility. The controller utilizes an ARC 700 processing core, providing an optimum balance between read/write performance, Data Care Management, and power fail protection.

Swissbit's **durabit™** X-60m SSDs deliver an impressive IOPS rate and highest endurance by combining MLC flash technology with a high-end controller architecture, firmware, and an optimized configuration. The **durabit™** SSDs are designed for applications requiring high data transfer rates up to 520/450 MBytes/s (MBPS) in sequential read/write access and 75K/75K input/output operations (IOPS) in 4 KByte random read/write access. This performance is achieved through an on-board DRAM cache and the controller 4-channel NAND flash interface that supports ONFI and Toggle 2 (400 MT/s) interface speeds.

An on-controller BCH Error Correction Code (ECC) engine provides the X-60m hardware ECC, which is capable of correcting up to 66 bits per 1 KByte page. This engine, combined with Swissbit's Data Care Management firmware, provides both passive and active data management strategies to insure data integrity and extract the maximum possible endurance and reliability from the NAND flash array. These strategies include, but are not limited to, Global Wear Leveling, Adaptive Read Refresh, Background Media Scan, and Dynamic Block Remapping.

The risk of data loss as a result of an unexpected power fail event is mitigated using a robust sequence of voltage regulators and detectors designed to insure a graceful shutdown of the controller and NAND flash array. A combination of both hardware and firmware power fail features prevent the possibility of resident data being corrupted during an unexpected power failure.

<sup>3</sup> Serial ATA IO rev 3.2 Section 6.6, Aug 7, 2013  
<http://www.jedec.org/standards-documents/docs/jesd218/>, Feb 2011  
 JEDEC M0-300B (2010/10)

## Related Documentation

- Serial Transport Protocols and Physical Interconnect (ATA/ATAPI-8)
- AT Attachment Interface Document, American National Standards Institute, X3.298-1997
- JEDEC MO-300 standard – JEDEC Publication 95: Registered and Standard Outlines for Solid State and Related Products

## 4.1 Performance Specifications

The X-60m read/write sequential and random I/O performance benchmarks are detailed below in Table 3.

**Table 3: Read/Write Performance<sup>4</sup>**

Capacity	Sequential Read (MBPS)	Sequential Write (MBPS)	Random Read (IOPs)	Random Write (IOPs)
8 GBytes	145	25	14,500	6,500
16 GBytes	280	55	26,500	13,000
30 GBytes	280	50	26,500	11,500
60 GBytes	520	90	51,000	23,000
120 GBytes	520	185	73,500	45,500
240 GBytes	520	355	75,000	75,000
480 GBytes	520	450	75,000	75,000

## 4.2 Current Consumption

The drive-level current consumption as a function of operating mode is shown below in Table 4.

**Table 4: Current Consumption<sup>5</sup>**

Drive Capacity	Sequential Read	Sequential Write	Random Read	Random Write	Idle	Slumber	Unit
8 GBytes	205	210	200	210	95	35	mA
16 GBytes	250	255	240	255	100	35	
30 GBytes	265	265	255	265	105	35	
60 GBytes	365	370	330	365	110	35	
120 GBytes	405	500	375	500	110	35	
240 GBytes	440	805	415	800	110	35	
480 GBytes	440	960	420	950	115	35	

<sup>4</sup> The values are measured using Crystal Disk Mark (CDM) across the full drive density. Performance depends on flash type and number, file/cluster size, and burst speed.

<sup>5</sup> All values are the maximum recorded at 25 °C, with nominal supply voltage, and SATA III performance test using IOMeter (512 byte-1 MByte transfer sizes).

## 4.3 Environmental Specifications

### 4.3.1 Recommended Operating Conditions

The recommended operating conditions for the X-60m SSD are provided in Table 5 below.

**Table 5: Recommended Operating Conditions<sup>6</sup>**

Parameter	Value
Commercial Operating Temperature	0 °C to 70 °C
Industrial Operating Temperature	-40 °C to 85 °C
Power Supply V <sub>CC</sub> Voltage	3.3 V ± 5%

### 4.3.2 Recommended Storage Conditions

The recommended storage conditions are listed below in Table 6.

**Table 6: Recommended Storage Conditions**

Parameter	Value
Commercial Storage Temperature	-40 °C to 85 °C
Industrial Storage Temperature	-40 °C to 85 °C

### 4.3.3 Shock, Vibration, and Humidity

The maximum shock, vibration, and humidity conditions are listed below in Table 7.

**Table 7: Shock, Vibration, and Humidity**

Parameter	Value
Non-Operating Shock	1,500 g, 0.5 ms duration, half-sine wave
Non-Operating Vibration	20 g Peak, 10-2000 Hz
Humidity (Non-Condensing)	85% RH 85 °C, 1000 hrs (JEDEC JESD22, method A101-B)

<sup>6</sup> Adequate airflow is required to ensure the drive temperature, as reported in the S.M.A.R.T. data, does not exceed the specified maximum operating temperature.



#### 4.4 Regulatory Compliance

The X-60m devices comply with the standards listed in the following table.

**Table 8: Regulatory Compliance**

Compliance	Country	Type	Standard(s)/Directive
CE	European Union	Certificate	2011/65/EU, 2012/19/EU, 2014/30/EU
CE/EMC	European Union	Compliance	2004/108/EC (AS/NZS CISPR22 :2009 +A1:2010, EN 61000-6-2:2005/AC:2005, EN 61000-6-4:2007/A1:2011 [EN55022:2010 Class B])
CE/RoHS	European Union	Compliance	2011/65/EU
CE/WEEE	European Union	Compliance	2012/19/EU
REACH	European Union	Certificate	1907/2006
FCC	United States	Certificate	47CFR Part 15, Class B
UL	United States	Compliance	UL/CSA 60950-1, Second Edition
VCCI	Japan	Compliance	ITE (Class A)
CCC	China	Compliance	Laws and Regulations of the People's Republic of China Governing Foreign-Related Matters (1991.7)
C-Tick	Australia	Compliance	AS/NZS CISPR22
TüV	Germany	Compliance	TüV IEC 60950-1; UL/CSA 60950-1, Second Edition
SATA-IO	International	Compliance	SATA Revision 1.4 Interoperability

#### 4.5 Mechanical Specifications

The X-60m SSD consists of a flash controller and NAND flash memory devices. The controller interfaces with a host system, allowing data to be written to and read from the flash memory array. The SSD has a PCIe mini-connector with a SATA interface. Physical dimensions are detailed in Table 9 below. Figure 3 on page 12 illustrates the X-60m dimensions and connector location.

**Table 9: Measured Physical Dimensions**

Physical Dimensions		Unit
Length	50.80±0.15	mm
Width	29.85±0.15	
Thickness (Max)	3.50	
Weight (Max Capacity)	7.00	g

## 4.6 Reliability and Endurance

The Mean Time Between Failure (MTBF) is specified to exceed the value listed below. Data reliability with effective error tolerance and data retention at the beginning and end of life is also provided.

**Table 10: Reliability**

Parameter	Value
MTBF (at 25 °C)	> 2,000,000 hours
Data Reliability	< 1 Non-Recoverable Error per 10 <sup>16</sup> Bits Read
Data Retention	10 Years at Start (JESD47), 1 Year at EOL

Endurance represented as both TeraBytes Written (TBW) and full Drive Writes Per Day (DWPD) for three different application scenarios is provided in the following table.

**Table 11: Endurance<sup>7</sup>**

Drive Capacity	Client		Enterprise		Embedded	
	TBW	DWPD	TBW	DWPD	TBW	DWPD
8 GBytes	16.28	1.90	4.00	0.47	4.40	0.55
16 GBytes	32.55		8.00		8.79	
30 GBytes	61.04		15.00		17.58	
60 GBytes	122.07		30.00		35.16	
120 GBytes	244.14		59.99		70.31	
240 GBytes	488.28		119.99		140.63	
480 GBytes	976.56		239.97		281.25	

## 4.7 Drive Geometry Specification

The X-60m drive geometry is set to report industry standard LBA settings per the IDEMA standard (LBA1-03). The values for each capacity are shown below in Table 12.

**Table 12: Drive Geometry**

Drive Capacity	User Capacity <sup>8</sup>	Total LBA	User Addressable Bytes
		Decimal	(Unformatted)
8 GBytes	7.5 GBytes	14,672,448	7,512,293,376
16 GBytes	15 GBytes	29,323,728	15,013,748,736
32 GBytes	30 GBytes	58,626,288	30,016,659,456
64 GBytes	60 GBytes	117,231,408	60,022,480,896
128 GBytes	120 GBytes	234,441,648	120,034,123,776
256 GBytes	240 GBytes	468,862,128	240,057,409,536
512 GBytes	480 GBytes	937,703,088	480,103,981,056

<sup>7</sup> Client and Enterprise workloads follow the JEDEC JESD219 standard; the Embedded workload creates a 4 KByte file and appends it. Enterprise workload values are measured based on 168 hours of runtime.

<sup>8</sup> 1 GByte = 10<sup>9</sup> bytes

## 5. Electrical Interface

The mini-SATA connector is the same as the miniPCIe and eeePC card connector, but the pinout is specific to the mSATA interface. Swissbit mSATA SSDs follow the SATA specification, offering a maximum performance of 6 Gbit/s, and look much like mini-PCI-Express devices, but the two connectors are not inter-compatible.

Figure 2: X-60m mSATA Electrical Interface

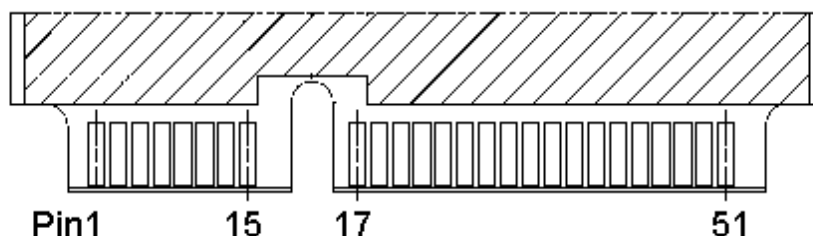

Table 13: Pin Assignment, Name, and Description

Description	Assignment	Pin	Pin	Assignment	Description
No Connect	N/A	1	2	+3.3V	3.3 V Source
No Connect	N/A	3	4	GND	Return Current Path
No Connect	N/A	5	6	+1.5V	No Connect
No Connect	N/A	7	8	N/A	No Connect
Return Current Path	GND	9	10	N/A	No Connect
No Connect	N/A	11	12	N/A	No Connect
No Connect	N/A	13	14	N/A	No Connect
Return Current Path	GND	15	16	N/A	No Connect
No Connect	N/A	17	18	GND	Return Current Path
No Connect	N/A	19	20	N/A	No Connect
Return Current Path	GND	21	22	N/A	No Connect
+SATA Differential Receive Signal	B+	23	24	3.3V	3.3 V Source
-SATA Differential Receive Signal	B-	25	26	GND	Return Current Path
Return Current Path	GND	27	28	1.5V	No Connect
Return Current Path	GND	29	30	N/A	No Connect
-SATA Differential Transmit Signal	A-	31	32	N/A	No Connect
+SATA Differential Transmit Signal	A+	33	34	GND	Return Current Path
Return Current Path	GND	35	36	N/A	No Connect <sup>9</sup>
Return Current Path	GND	37	38	N/A	No Connect
3.3 V Source	3.3V	39	40	GND	Return Current Path
3.3 V Source	3.3V	41	42	N/A	No Connect
Optional Return Current Path	NC	43	44	DEVSLP	Low Power Device Sleep Mode
No Connect	Reserved	45	46	N/A	No Connect
No Connect	Reserved <sup>10</sup>	47	48	+1.5V	No Connect
Device Activity/LED	DA	49	50	GND	Return Current Path
Pulled to GND by Device	Presence Detection	51	52	3.3V	3.3 V Source

<sup>9</sup> Planned for power fail signal input.

<sup>10</sup> Optional – could be used for write protection or drive erase.

## 6. Package Mechanical

**NOTE:** The dimensions in the following figures are the maximum values based on the JEDEC standard. For the product dimensions, see the *Mechanical Specifications* section on page 9.

Figure 3: mSATA SSD Drive Dimensions in mm [in]

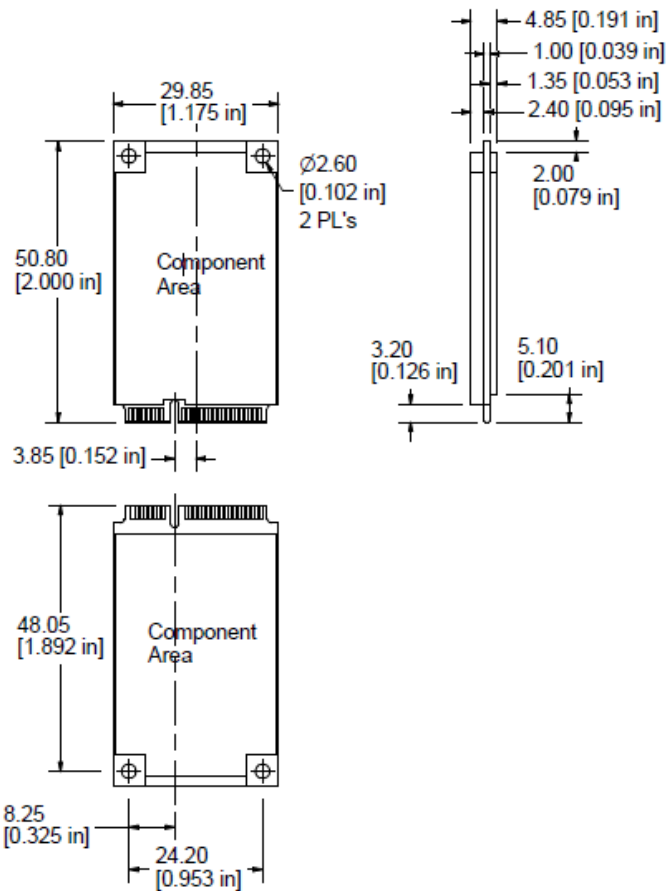
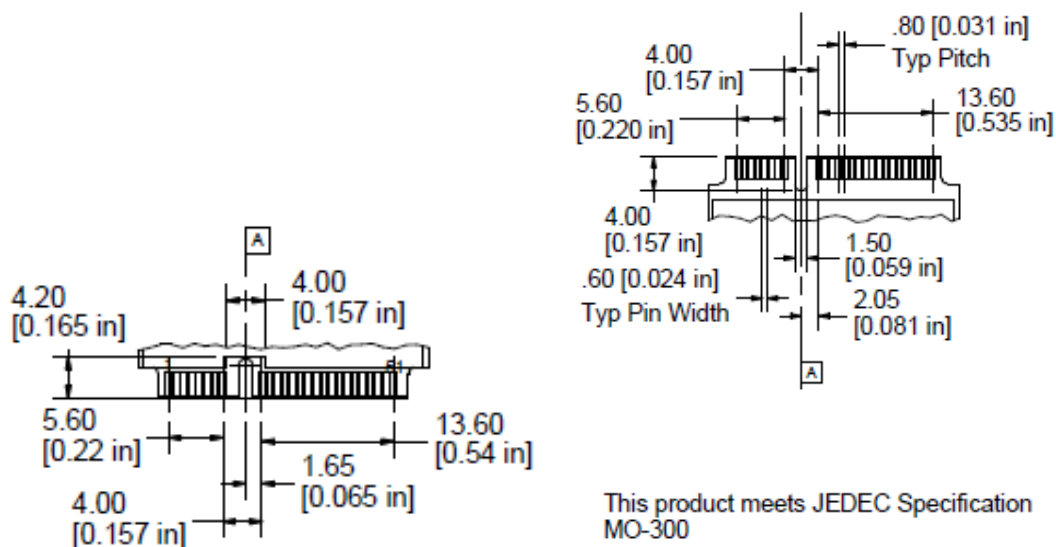

Figure 4: mSATA Connector Dimensions in mm [in]



## 7. ATA Commands

This section provides information on the ATA commands supported by the SSD. The commands are issued to the ATA by loading the required registers in the command block with the supplied parameter, and then writing the command code to the register. For backward compatibility, some commands are implemented as a "no operation". See Table 14 for a list of ATA commands the device supports. For details about setting up the command registers, see the latest ATA Specification.

**Table 14: ATA Command Set**

Command	Code	Protocol
<b>General Feature Set</b>		
Execute Device Diagnostic	90h	Execute Device Diagnostic
Flush Cache	E7h	Non-data
Identify Device	ECh	PIO data-in
Initialize Drive Parameters	91h	Non-data
Read DMA	C8h	DMA
Read Log Ext	2Fh	PIO data-in
Read Multiple	C4h	PIO data-in
Read Sector(s)	20h	PIO data-in
Read Verify Sector(s)	40h or 41h	Non-data
Set Feature	EFh	Non-data
Set Multiple Mode	C6h	Non-data
Write DMA	CAh	DMA
Write Multiple	C5h	PIO data-out
Write Sector(s)	30h	PIO data-out
NOP	00h	Non-data
Read Buffer	E4h	PIO data-in
Write Buffer	E8h	PIO data-out
<b>Power Management Feature Set</b>		
Check Power Mode	E5h or 98h	Non-data
Idle	E3h or 97h	Non-data
Idle Immediate	E1h or 95h	Non-data
Sleep	E6h or 99h	Non-data
Standby	E2h or 96h	Non-data
Standby Immediate	E0h or 94h	Non-data
<b>Security Mode Feature Set</b>		
Security Set Password	F1h	PIO data-out
Security Unlock	F2h	PIO data-out
Security Erase Prepare	F3h	Non-data
Security Erase Unit	F4h	PIO data-out
Security Freeze Lock	F5h	Non-data
Security Disable Password	F6h	PIO data-out
<b>S.M.A.R.T. Feature Set</b>		
S.M.A.R.T. Disable Operations	B0h	Non-data
S.M.A.R.T. Enable/Disable Autosave	B0h	Non-data
S.M.A.R.T. Enable Operations	B0h	Non-data
S.M.A.R.T. Execute Off-Line Immediate	B0h	Non-data
S.M.A.R.T. Read Data	B0h	PIO data-in
S.M.A.R.T. Read Log	B0h	PIO data-in
S.M.A.R.T. Read Threshold	B0h	PIO data-in
S.M.A.R.T. Return Status	B0h	Non-data
S.M.A.R.T. Save Attribute Values	B0h	Non-data
S.M.A.R.T. Write Attribute Values	B0h	Non-data
S.M.A.R.T. Write Log	B0h	PIO data-out

Command	Code	Protocol
<b>Host Protected Area Feature Set</b>		
Read Native Max Address	F8h	Non-data
Set Max Address	F9h	Non-data
Set Max Set Password	F9h	PIO data-out
Set Max Lock	F9h	Non-data
Set Max Freeze Lock	F9h	Non-data
Set Max Unlock	F9h	PIO data-out
<b>48-Bit Address Feature Set</b>		
Flush Cache Ext	EAh	Non-data
Read Sector(s) Ext	24h	PIO data-in
Read DMA Ext	25h	DMA
Read Multiple Ext	29h	PIO data-in
Read Native Max Address Ext	27h	Non-data
Read Verify Sector(s) Ext	42h	Non-data
Set Max Address Ext	37h	Non-data
Write DMA Ext	35h	DMA
Write DMA FUA Ext	3Dh	DMA
Write Multiple Ext	39h	PIO data-out
Write Multiple FUA Ext	CEh	PIO data-out
Write Sector(s) Ext	34h	PIO data-out
<b>NCQ Feature Set</b>		
Read FPDMA Queued	60h	DMA Queued
Write FPDMA Queued	61h	DMA Queued
<b>Others</b>		
Data Set Management	06h	DMA
Seek	70h	Non-data

## 8. Identify Device Information

The following table describes the 512 bytes of data the drive returns for the Identify Device command (ECh).

**Table 15: Identify Device Information**

Word(s)	Default Value	Total Bytes	Data Field Type Information
0	0040h*	2	Standard Configuration Fixed (optional 848Ah for removable)
1	XXXXh	2	Default number of cylinders
2	0000h	2	Reserved
3	00XXh	2	Default number of heads
4-5	0000h	4	Obsolete
6	XXXXh	2	Default number of sectors per track
7-8	XXXXh	4	Number of sectors per drive (Word 7 = MSW, Word 8 = LSW)
9	0000h	2	Obsolete
10-19	aaaa	20	Serial number in ASCII (right-justified)
20-22	0000h	6	Obsolete
23-26	SBR11015	8	Firmware revision in ASCII (big-endian byte order in Word)
27-46	XXXX*	40	Model number in ASCII (right-justified)
47	8002h	2	Maximum number of sectors on Read/Write Multiple command
48	4000h	2	Trusted Computing feature set not supported
49	2F00h*	2	Standby Timer, DMA, LBA, IORDY supported
50	4000h	2	Capabilities
51	0000h	2	PIO data transfer cycle timing mode 0
52	0000h	2	Obsolete
53	0007h*	2	Words 88 and 64-70 valid
54	XXXXh	2	Current numbers of cylinders
55	XXXXh	2	Current numbers of heads
56	XXXXh	2	Current sectors per track
57-58	XXXXh	4	Current capacity in LBAs (Word 57 = LSW, Word 58 = MSW)
59	910Xh*	2	Multiple sector setting (host changeable)
60-61	XXXXh	4	Total number of sectors addressable in LBA Mode
62	0000h	2	Obsolete
63	0007h*	2	Multiword DMA transfer support modes 2, 1, and 0 (host changeable)
64	0003h	2	Advanced PIO modes supported
65	0078h*	2	Minimum Multiword DMA transfer cycle time per Word
66	0078h*	2	Recommended Multiword DMA transfer cycle time
67	0078h*	2	Minimum PIO transfer cycle time without flow control
68	0078h*	2	Minimum PIO transfer cycle time with IORDY flow control
69	4D20h	2	Trimmed range returning zeros, 28-bit commands supported, download
70-74	0000h	10	Reserved
75	001Fh	2	Queue Depth
76	830Eh	2	SATA Capabilities
77	0086h	2	Additional SATA Capabilities
78	014Ch	2	SATA feature support
79	0040h*	2	SATA features enabled (host changeable)
80	03F0h	2	Major revision
81	0000h	2	Minor revision
82-84	746Bh*	6	Features/command sets supported
85-87	7469h*	6	Features/command sets enabled (may change in operation)
88	407Fh*	2	UDMA mode supported
89	0002h*	2	Time for security erase unit completion
90	0002h*	2	Time for enhanced security erase completion
91	0000h	2	Power Management
92	FFFEh*	2	Master password revision code
93-99	0000h*	14	Reserved

Word(s)	Default Value	Total Bytes	Data Field Type Information
100-103	XXXXh	8	Max user LBA48 address feature set
104-105	0000h	4	Reserved
106	4000h	2	Sector size
107-118	0000h	24	Reserved
119-120	4018h	4	Command set supported settings
121-127	0000h	14	Reserved
128	0021h*	2	Security Status (may change in operation)
129-159	XXXXh	62	"Swissbit SSD"
160	0000h*	2	Power requirement
161	0000h	2	Reserved
162	0000h	2	Management schemes
163	0000h	2	IDE Timing
164	0000h	2	IO Timing
165-168	0000h	8	Reserved
169	0001h	2	Data Set Management supported
170-208	XXXXh	78	Reserved
209	4000h	2	Logical block alignment
210-216	0000h	14	Reserved
217	0001h*	2	Nominal media rotation rate: Solid State Device
218-221	0000h	8	Reserved
222	107Fh	2	Transport major revision
223-233	0000h	22	Reserved
234	0001h	2	Minimum number of 512-byte units per segmented download
235	0200h	2	Maximum number of 512-byte units per segmented download
236-254	0000h	38	Reserved
255	XXXXh	2	Integrity Word

\* Standard values for full functionality are listed. Values depend on device configuration.

## 9. S.M.A.R.T. Functionality

The X-60m SSD fully supports the ATA Specification for Self-Monitoring, Analysis, and Reporting Technology (S.M.A.R.T.). For details about the S.M.A.R.T. subcommands and attributes, see the *S.M.A.R.T. Attribute Technical Reference Guide*.

### 9.1 S.M.A.R.T. Subcommands

The following table lists the supported S.M.A.R.T. subcommands and the Features register values.

**Table 16: S.M.A.R.T. Features Supported**

Features	Operation
D0h	S.M.A.R.T. Read Data
D1h	S.M.A.R.T. Read Attribute Thresholds
D2h	S.M.A.R.T. Enable/Disable Autosave
D3h	S.M.A.R.T. Save Attribute Values
D4h	S.M.A.R.T. Execute Off-Line Immediate
D5h	S.M.A.R.T. Read Log
D6h	S.M.A.R.T. Write Log
D7h	S.M.A.R.T. Write Attribute Thresholds
D8h	S.M.A.R.T. Enable Operations
D9h	S.M.A.R.T. Disable Operations
DAh	S.M.A.R.T. Return Status

The device aborts any S.M.A.R.T. subcommands with Features register values not listed in the above table.



## 9.2 S.M.A.R.T. Read Data

When the drive receives the S.M.A.R.T. Read Data subcommand, it returns one sector (512 bytes) of data. See the following table for the data structure of this sector.

**Table 17: S.M.A.R.T. Data Structure**

Byte(s)	Value	Description
0-1	0100h	S.M.A.R.T. structure version
2-361	XXh	Attribute entries 1 to 30 (see Table 19)
362	00h	Off-line data collection status (no off-line data collection started)
363	00h	Self-test execution status byte (self-test completed)
364-365	0000h	Total time, in seconds, to complete off-line data collection
366	00h	Vendor specific
367	00h	Off-line data collection capability (no off-line data collection)
368-369	0002h	S.M.A.R.T. capabilities
370	01h	Error logging capability
371	00h	Vendor specific
372	01h	Short self-test routine recommended polling time, in minutes
373	01h	Extended self-test routine recommended polling time, in minutes
374	01h	Conveyance self-test routine recommended polling time, in minutes
375-385	00h	Reserved
386-395	XXh	Firmware version in ASCII ("SBR11015")
396-399	00h	Reserved
400-405	XXh	Controller model in ASCII ("SM2246")
406-510	00h	Reserved
511	XXh	Data structure checksum

## 9.3 S.M.A.R.T. Attributes

The X-60m drives support the S.M.A.R.T. attributes listed in the following table.

**Table 18: S.M.A.R.T. Attributes**

ID	Worst	Threshold	Attribute	Description
01h	100	0	Raw Read Error Rate	Total number of Cyclic Redundancy Check (CRC) errors that occurred over the SATA interface
05h	100	0	Reallocated Sector Count	Total number of runtime identified (field marked) bad blocks
09h	100	0	Power-On Hours	Total hours that the device has been powered on and operational (not in Sleep mode)
0Ch	100	0	Power Cycle Count	Total number of power cycles that have occurred during the life of the drive
A0h	100	0	Uncorrectable Sector Count	Total number of sectors read (active or passive) with UECC errors
A1h	100	0*	Spare Blocks	Total number of spare blocks currently available
A3h	100	0	Number of Initial Invalid Blocks	Total number of initially identified (factory marked and pretest) bad blocks
A4h	100	0	Total Erase Count	Total number of erase operations that have ever been performed on all currently valid blocks (excluding the system, bad and reserved blocks)
A5h	100	0	Maximum Erase Count	The maximum number of erase operations that have ever been performed on a single block (excluding the system, bad and reserved blocks)
A6h	100	0	Minimum Erase Count	The minimum number of erase operations that have ever been performed on a single block (excluding the system, bad and reserved blocks)
A7h	100	0*	Average Erase Count	The average number of erase operations that have ever been performed on a single block (excluding the system, bad and reserved blocks)

ID	Worst	Threshold	Attribute	Description
A8h	100	0	Maximum Specified Erase Count	The specified maximum erase count; equivalent to number of program/erase (P/E) cycles rated for the device
A9h	100	0	Power on UECC Count	The number of uncorrectable errors encountered during a power up event
C0h	100	0	Initial Spare Block Count	Total number of original spare blocks
C1h	100	0	Dynamic Remaps	Total number of dynamic remap operations
C2h	100	0	Temperature	Temperature (minimum, maximum, and current) of the device
C3h	100	0	Flash ECC Recovered	Total number of times the read-retry process was required to recover data
C4h	0	0	Reallocation Event Count	Total count of remapping operations
C6h	100	0	Uncorrectable Sector Count Offline	Total number of sectors read (active only) with UECC errors
C7h	100	0	SATA PHY CRC Error Count	Total count of PHY errors (including CRC) that occurred over the interface cable
D7h	100	0	TRIM Count	Total number of TRIM commands issued by the host
EBh	100	0	Total Flash LBAs Written	The lower 7 bytes of the total number of LBAs (in 32 KByte increments) written to the flash; the higher 5 bytes are located in attribute EDh
EDh	100	0	Total Flash LBAs Written Expanded	The upper 5 bytes of the total number of LBAs (in 32 KByte increments) written to the flash; the lower 7 bytes are located in attribute EBh
F1h	100	0	Total Host LBAs Written	The lower 7 bytes of the total number of LBAs written to the device by the host; the higher 5 bytes are located in attribute F3h
F2h	100	0	Total Host LBAs Read	The lower 7 bytes of the total number of LBAs read from the device by the host; the higher 5 bytes are located in attribute F4h
F3h	100	0	Total Host LBAs Written Expanded	The upper 5 bytes of the total number of LBAs written to the device by the host; the lower 7 bytes are located in attribute F1h
F4h	100	0	Total Host LBAs Read Expanded	The upper 5 bytes of the total number of LBAs read from the device by the host; the lower 7 bytes are located in attribute F2h
F8h	100	0	SSD Remaining Life	Percent of SSD life remaining on the SSD (a value from 0 to 64h), normalized to 100; based upon Average Erase Count (A7h) scaled by the Maximum Specified Erase Count (A8h)
F9h	100	0	Spare Block Remaining Life	Percent of spare blocks remaining

\*These threshold values are changeable using the Write Attribute Thresholds command.

#### 9.4 S.M.A.R.T. Attribute Entry Structure

Each attribute entry consists of 12 bytes. See the following table for the data structure of each entry.

Table 19: Attribute Entry

Byte(s)	Value	Description
0	XXh	Attribute ID (see Table 18)
1-2	XXXXh	Flags (little-endian)
3	XXh	Attribute value as a percentage
4	XXh	Worst value as a percentage
5-8	XXXXh	Raw value (little-endian)
9-11	00h	Reserved

## 10. Part Number Decoder

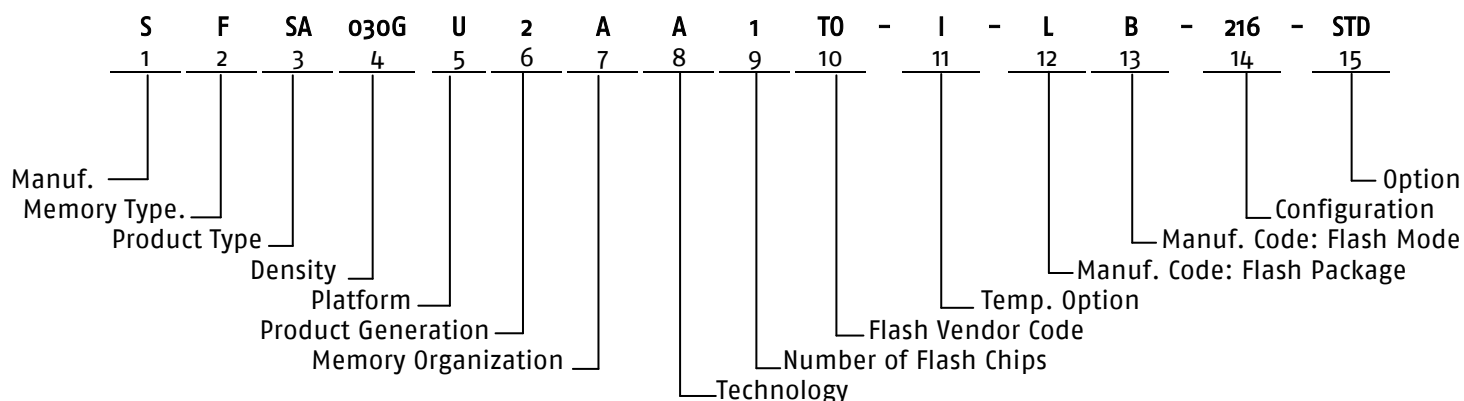

### 10.1 Manufacturer

Swissbit code	S
---------------	---

### 10.2 Memory Type

Flash	F
-------	---

### 10.3 Product Type

SATA Interface	SA
----------------	----

### 10.4 Density

8 GBytes	008G
15 GBytes	015G
30 GBytes	030G
60 GBytes	060G
120 GBytes	120G
240 GBytes	240G
480 GBytes	480G

### 10.5 Platform

mSATA SSD	U
-----------	---

### 10.6 Product Generation

### 10.7 Memory Organization

x8	A
----	---

### 10.8 Technology

X60m Series	A
-------------	---

### 10.9 Number of Flash Chips

1 Flash	1
2 Flash	2
4 Flash	4

### 10.10 Flash Code

Toshiba	T0
---------	----

### 10.11 Temperature Option

Industrial Temperature Range: -40 °C to 85 °C	I
Standard Temperature Range: 0 °C to 70°C	C

### 10.12 Die Classification

MLC MONO (single die package)	G
MLC DDP (dual die package)	L
MLC QDP (quad die package)	H
MLC ODP (octal die package)	O

### 10.13 Pin Mode

	TSOP	BGA
Single nCE and Single R/nB	S	A
Dual nCE and Dual R/nB	T	B
Quad nCE and Quad R/nB	U	C
Octal nCE and Dual R/nB	*	D

\*Not Available

### 10.14 Drive Configuration XYZ

#### X = Type

Drive Mode	PIO	DMA Support	X
Fix	Yes	Yes	2

#### Y = Firmware Revision

FW Revision	Y
SBR11015	1

#### Z = Max Transfer Mode

Max PIO Mode/CIS	Z
UDMA6 (MWDMA2, PIO4)	6

### 10.15 Option

Swissbit/Standard	STD
-------------------	-----

# 11. Swissbit mSATA SSD Marking Specification

## 11.1 Top View



## 11.2 Label Content

- Part Number
- Lot Code/Identification
- Type Code
- Density
- Manufacturing Date
- Swissbit Logo
- Country of Origin
- CE Logo
- FCC Logo
- WEEE Logo

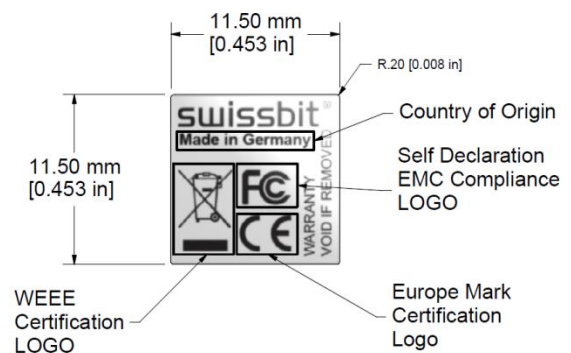
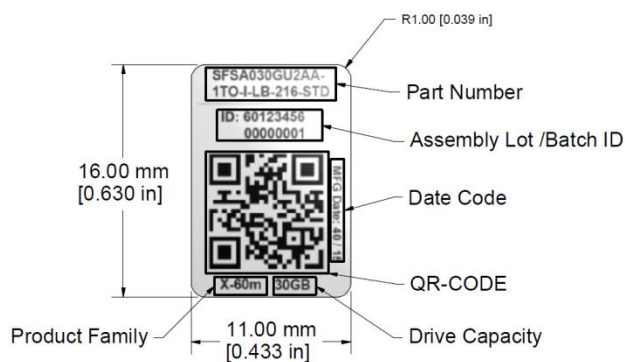

## 12. Revision History

**Table 20: Document Revision History**

Date	Revision	Description	Revision Details
27-Mar-2015	100	First preliminary release.	
7-Jul-2015	95_r08	Secondary Review, photos added, TOC needs edit.	
23-Jul-2015	0.96	Removed CE declaration and footer on first page, changed information in the RoHS/WEEE declaration, added feature icons. Command list updated, command description, ATA ID, S.M.A.R.T. description. Updated performance and current data to reflect interleave conditions. Added new label details and mechanical drawings.	
30-Jul-2015	1.00	First initial release.	
30-Sept-2015	1.01	Updated product picture, S.M.A.R.T. attributes (Coh), and the RoHS, ACPEIP and WEEE declaration and the feature icons.	Doc. req. no. 0775
4-Jan-2016	1.02	Updated performance and current values. Added Write Thresholds command. Modified S.M.A.R.T. attribute descriptions for clarity. Removed ATA command byte structures. Added slumber current. Added DEVSLP compatible to list of features. Updated storage temperature. Updated copyright date.	Doc. req. no. 0911
22-Mar-2016	1.03	Added JEDEC information for endurance workloads. Added support for FUA commands. Added durabit information. Added regulatory information.	Doc. req. no 1022
27-Jun-2016	1.04	Added available part number table. Added footnote about TBW.	Doc. req. no 1147
31-Aug-2016	1.05	Fixed typo.	Doc. req. no. 1250
4-Nov-2016	1.06	Corrected endurance values and added note regarding maximum dimensions.	Doc. req. no. 1353

### Disclaimer:

No part of this document may be copied or reproduced in any form or by any means, or transferred to any third party, without the prior written consent of an authorized representative of Swissbit AG ("SWISSBIT"). The information in this document is subject to change without notice. SWISSBIT assumes no responsibility for any errors or omissions that may appear in this document, and disclaims responsibility for any consequences resulting from the use of the information set forth herein. SWISSBIT makes no commitments to update or to keep current information contained in this document. The products listed in this document are not suitable for use in applications such as, but not limited to, aircraft control systems, aerospace equipment, submarine cables, nuclear reactor control systems and life support systems. Moreover, SWISSBIT does not recommend or approve the use of any of its products in life support devices or systems or in any application where failure could result in injury or death. If a customer wishes to use SWISSBIT products in applications not intended by SWISSBIT, said customer must contact an authorized SWISSBIT representative to determine SWISSBIT willingness to support a given application. The information set forth in this document does not convey any license under the copyrights, patent rights, trademarks or other intellectual property rights claimed and owned by SWISSBIT. The information set forth in this document is considered to be "Proprietary" and "Confidential" property owned by SWISSBIT.

ALL PRODUCTS SOLD BY SWISSBIT ARE COVERED BY THE PROVISIONS APPEARING IN SWISSBIT'S TERMS AND CONDITIONS OF SALE ONLY, INCLUDING THE LIMITATIONS OF LIABILITY, WARRANTY AND INFRINGEMENT PROVISIONS. SWISSBIT MAKES NO WARRANTIES OF ANY KIND, EXPRESS, STATUTORY, IMPLIED OR OTHERWISE, REGARDING INFORMATION SET FORTH HEREIN OR REGARDING THE FREEDOM OF THE DESCRIBED PRODUCTS FROM INTELLECTUAL PROPERTY INFRINGEMENT, AND EXPRESSLY DISCLAIMS ANY SUCH WARRANTIES INCLUDING WITHOUT LIMITATION ANY EXPRESS, STATUTORY OR IMPLIED WARRANTIES OF MERCHANTABILITY OR FITNESS FOR A PARTICULAR PURPOSE.

©2016 SWISSBIT AG All rights reserved.