

## Flexible LED Controller Simplifies Automotive Exterior Lighting Design

### Introduction

LEDs are becoming very popular in automotive exterior lighting, thanks to their superior lighting characteristics, efficiency, and flexibility in design implementation. They can be used in a variety of light shapes and with different features. The required multiplicity of LED configurations in automotive exterior lighting, combined with the variability of the car battery voltage, forces the use of a large number of integrated circuits, each tailored to a specific vehicle lighting function. This article introduces a flexible controller IC that supports many architectures and greatly simplifies automotive exterior lighting design.



Figure 1. LED-Powered Car Headlight

### Powering the LEDs

LEDs have many automotive applications and are used in diverse arrangements from a single LED lamp to LED strings and matrices. Functions like high beam, low beam, fog lights, daytime running lights (DRLs), position and turn signal lights can all be implemented with LEDs. Powered from a car battery, the input voltage is typically 12V but can be as high as 16V on a fully charged battery. Vehicles employing start/stop technology experience large voltage dips when the engine starts, so the lower limit for the power source can be well below the typical 12V but can often be 6V or even lower.

The switching regulators powering the LEDs must meet specific requirements. They must operate over the entire voltage range provided by the battery and be able to survive 60V 'dump' voltage transients. The current amplitude must be very accurate, since it controls the LED color. For light dimming, time-slicing the LED current (by using pulse-width modulation or PWM) reduces the light's brightness without affecting its color. The PWM dimming frequency must be above 100Hz to be undetected as a flicker by the human eye. A high and well-controlled PWM switching frequency above the AM frequency band is required to reduce radio frequency interference. Spread-spectrum modulation is also necessary to meet EMI standards. Finally, high efficiency helps reduce heat generation and improves system reliability.

### Basic Headlight System

A basic headlight system architecture that can accommodate a series of LEDs uses a boost converter. In the boost controller IC of Figure 2, one of the three feedback loops (CURRENT LOOP) ensures tight control of the output current. The other two feedback loops perform overvoltage protection (OVP LOOP) and overcurrent protection (OCP LOOP) for the string of 12 diodes, which develops 42V across the string (3.5V per LED).

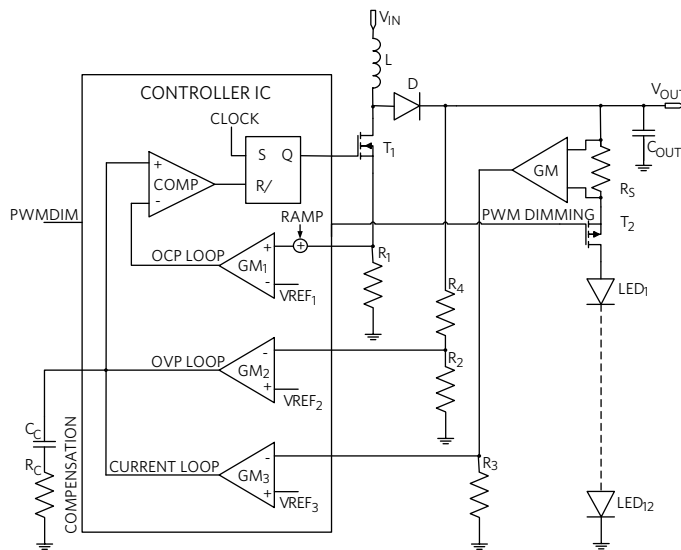

Figure 2. Typical Boost LED Control System

In addition to current and voltage control, the IC must be equipped with all the features previously described (dimming, spread spectrum, etc.). High-side current sensing (via the resistors, Rx) is required to protect the LED system in case of shorts from the output to the ground or battery input.

### Flexible LED Controller Architecture

Ideally, an LED controller should have a flexible architecture that supports multiple configurations that can implement different features. We have discussed the boost configuration but we should also consider the buck-boost configuration. A buck-boost mode configuration is necessary if the diode string is short, for example two or three LEDs (7V or 10.5V), against a battery voltage that can vary from less than 6V (cold crank) up to 16V. If the concern is input-to-output isolation, then a SEPIC (discontinuous output current) or a Chuck (continuous output current) converter may be the right solution. A single controller that supports many architectures has clear advantages of economies of scale and ease of reuse.

The **MAX20090** is the most flexible controller for driving LEDs, allowing boost, high-side buck, SEPIC mode, or buck-boost mode configurations. The device is a single-channel high-brightness LED (HB LED) controller for automotive front-lighting applications such as high beam, low beam, DRLs, turn-signal indicators, and fog lights. The HB LED controller can accept a 5V to 65V input voltage and drives a string of LEDs with a 65V maximum output voltage. The PWM input provides LED dimming ratios of up to 1000:1 and the ICTRL input provides additional analog-dimming capability.

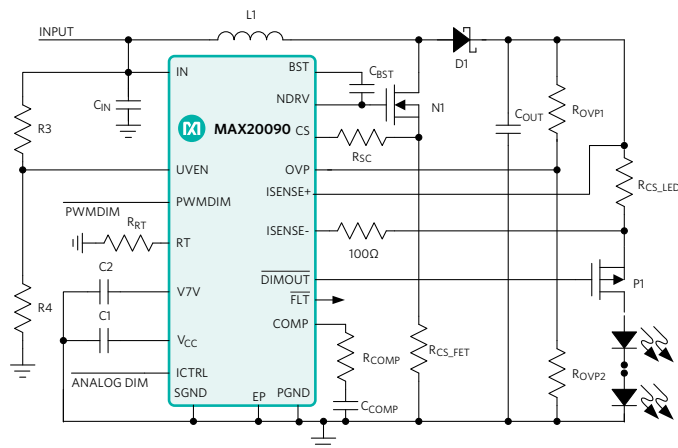

Figure 3. MAX20090 Boost LED System

### Low EMI and Low Noise

A 200kHz to 2.2MHz programmable switching frequency allows the MAX20090 to operate well outside the AM radio frequency band, avoiding interference with the automotive radio signal. Built-in, spread-spectrum modulation also improves

electromagnetic compatibility performance. Spread-spectrum dithering is added to the oscillator to alleviate EMI problems in the LED controller. The boost converter oscillator (RT pin in Figure 3) is synchronized to the positive-going edge of the PWM dimming pulse (PWMDIM). This means that the NDRV pulse goes high at the same time as the positive-going pulse on PWMDIM (see Figure 3). Synchronizing the RT oscillator to the PWMDIM pulse guarantees that the switching-frequency variation over a period of a PWMDIM pulse is the same from one PWMDIM pulse to the next. This prevents flickering during PWM dimming when spread spectrum is added to the RT oscillator.

### Conclusion

We have discussed the automotive headlight environment including its various functions, concerns, and corresponding LED controller configurations. The MAX20090 LED controller supports a high number of architectures for automotive exterior lighting and greatly simplifies their design. The flexible design options use boost, high-side buck, SEPIC mode, or buck-boost mode configurations, providing clear advantages in economies of scale and ease of reuse. In addition, the high switching frequency allows operation above the AM radio frequency band while built-in spread-spectrum modulation reduces electromagnetic interference.

**Dump:** A large transient voltage consequent to the car battery being disconnected from the rest of the system (alternator and electronic loads) during operation

**DRL:** Daytime running light

**EMI:** Electromagnetic interference

**LED:** Light-emitting diode

**AM broadcasting band (LF):** Radio frequencies in the range of 148.5kHz to 283.5kHz

**AM broadcasting band (MF):** Radio frequencies in the range of 525kHz to 1705kHz

**PWM:** Pulse-width modulation

**SEPIC:** Single-ended primary inductance converter

Learn more

[MAX20090 Automotive High-Voltage High-Brightness LED Controller](#)

Design Solutions No. 53

Rev 0; June 2017

**Need Design Support?**

**Call 888 MAXIM-IC (888 629-4642)**

[Find More Design Solutions](#)

Maxim Integrated  
160 Rio Robles  
San Jose, CA 95134 USA  
408-601-1000

[maximintegrated.com/design-solutions](http://maximintegrated.com/design-solutions)

