

N Male for SPP-250 Cable



**RoHS
Compliant**



Specifications

Impedance	: 50Ω
Frequency Range	: 0-11 GHz
VSWR	: <1.3:1 @ 9 GHz
Insertion Loss	: -0.06dB @ √GHz
Operating Temperature	: -55°C to +150°C

Diagram

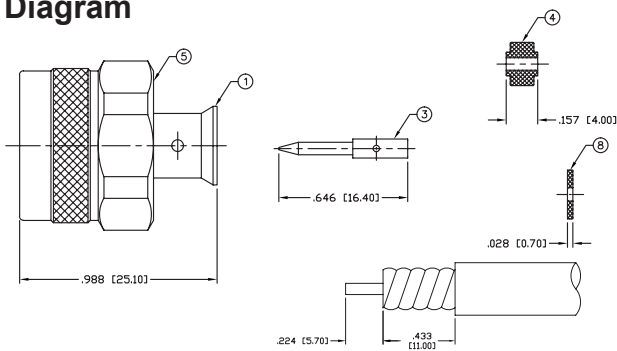

No.	Description	Material	Finish	Qty
1	Body	Brass	White Bronze	1
2	Insulator	PTFE	-	
3	Pin	Brass	Silver	
4	Insert	PTFE	-	
5	Shell	Brass	White Bronze	
6	Gasket	Rubber	-	
7	Retaining Ring	BeCu	White Bronze	
8	Spacer	PTFE	-	

Dimensions : Inches (Millimetres)

Assembly Instructions

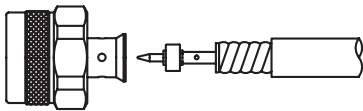

- Step 1: Cut end of cable evenly. Strip cable to dimensions as shown. All cuts are to be clean and square. Do not nick enter conductor when cutting. If using heat shrink tubing slide onto cable first.
- Step 2: Slide Spacer and pin onto cable center conductor until it yields against the cable dielectric. Solder pin in place.
- Step 3: Slide insert onto pin.
- Step 4: Insert the pin into the body until it yields against the back of the connector. Solder connector and cable outer conductor in place.

Part Number Table

Description	Part Number
N Male for SPP-250LLPL Cable	MC002024

Important Notice : This data sheet and its contents (the "Information") belong to the members of the Premier Farnell group of companies (the "Group") or are licensed to it. No licence is granted for the use of it other than for information purposes in connection with the products to which it relates. No licence of any intellectual property rights is granted. The Information is subject to change without notice and replaces all data sheets previously supplied. The Information supplied is believed to be accurate but the Group assumes no responsibility for its accuracy or completeness, any error in or omission from it or for any use made of it. Users of this data sheet should check for themselves the Information and the suitability of the products for their purpose and not make any assumptions based on information included or omitted. Liability for loss or damage resulting from any reliance on the Information or use of it (including liability resulting from negligence or where the Group was aware of the possibility of such loss or damage arising) is excluded. This will not operate to limit or restrict the Group's liability for death or personal injury resulting from its negligence. Multicomp is the registered trademark of the Group. © Premier Farnell Limited 2016.

www.element14.com
www.farnell.com
www.newark.com

