

FEATURES

- 1-, 2-, or 3-phase operation at up to 750 kHz per phase
- ±8 mV worst-case differential sensing error over temperature
- Interleaved PWM outputs for driving external high power MOSFET drivers
- Automatic power-saving modes maximize efficiency during light load and deeper sleep operation
- Soft transient control reduces inrush current and audio noise
- Active current balancing between output phases
- Independent current limit and load line setting inputs for additional design flexibility
- Built-in power-good masking supports VID on-the-fly
- 7-bit digitally programmable 0.3 V to 1.5 V output
- Overload and short-circuit protection with programmable latch-off delay
- Built-in clock enable output delays CPU clock until CPU supply voltage stabilizes

APPLICATIONS

Notebook power supplies for next generation Intel® processors

GENERAL DESCRIPTION

The ADP3207¹ is a high efficiency, multiphase, synchronous, buck-switching regulator controller optimized for converting notebook battery voltage into the core supply voltage required by high performance Intel processors. The part uses an internal 7-bit DAC to read voltage identification (VID) code directly from the processor that sets the output voltage. The phase relationship of the output signals can be programmed to provide 1-, 2-, or 3-phase operation, allowing for the construction of up to three interleaved buck-switching stages.

The ADP3207 uses a multimode architecture to drive the logic-level PWM outputs at a programmable switching frequency that can be optimized depending on the output current requirement. The part switches between multiphase and single-phase operation to maximize its effectiveness under all load conditions. In addition, the ADP3207 includes a programmable slope function to adjust the output voltage as a function of the load current. As a result, it is always best positioned for a system transient.

¹ Patent 6,683,441.

FUNCTIONAL BLOCK DIAGRAM

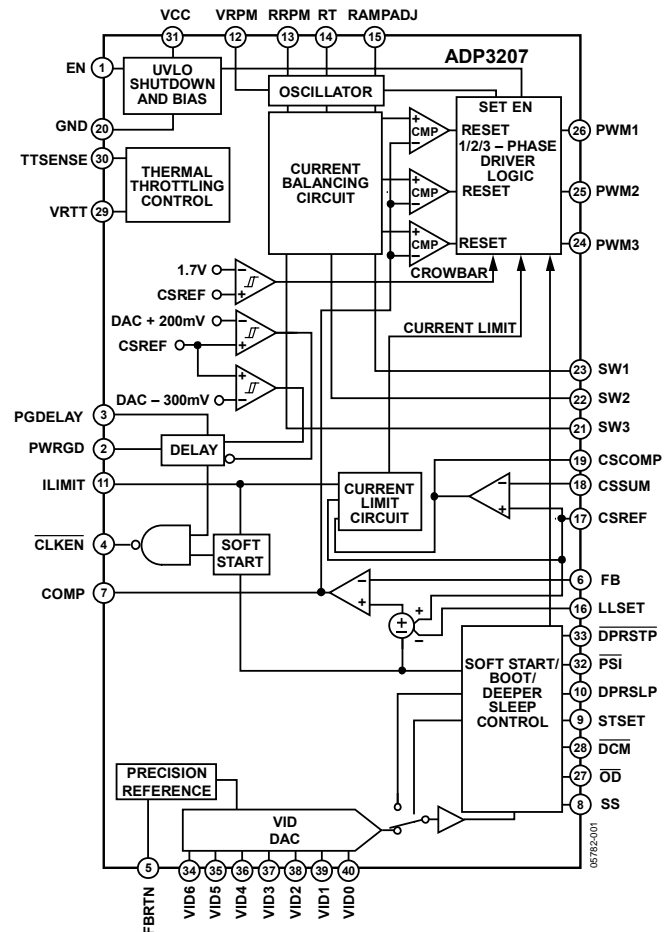

Figure 1.

The chip also provides accurate and reliable short-circuit protection, adjustable current limiting, and a delayed power-good output that accommodates on-the-fly output voltage changes requested by the CPU.

The ADP3207 is specified over the extended commercial temperature range of 0°C to 100°C and is available in a 40-lead LFCSP package.

Rev. 0

Information furnished by Analog Devices is believed to be accurate and reliable. However, no responsibility is assumed by Analog Devices for its use, nor for any infringements of patents or other rights of third parties that may result from its use. Specifications subject to change without notice. No license is granted by implication or otherwise under any patent or patent rights of Analog Devices. Trademarks and registered trademarks are the property of their respective owners.

TABLE OF CONTENTS

Features	1	Output Crowbar	16
Applications.....	1	Reverse Voltage Protection	16
General Description	1	Output Enable and UVLO	16
Functional Block Diagram	1	Thermal Throttling Control	16
Revision History	2	Application Information.....	20
Specifications.....	3	Setting the Clock Frequency for PWM Mode.....	20
Test Circuits.....	6	Soft-Start and Current-Limit Latch-Off Delay Times	20
Absolute Maximum Ratings.....	7	PWRGD Delay Timer.....	20
ESD Caution.....	7	Inductor Selection	20
Pin Configuration and Function Descriptions.....	8	C _{OUT} Selection	22
Typical Performance Characteristics	10	Power MOSFETs.....	23
Theory of Operation	11	Ramp Resistor Selection.....	24
Number of Phases.....	11	Setting the Switching Frequency for RPM Mode Operation of Phase 1	25
Operation Modes.....	11	Current-Limit Setpoint.....	25
Switch Frequency Setting	12	Feedback Loop Compensation Design.....	25
Output Voltage Differential Sensing.....	12	C _{IN} Selection and Input Current D _I /D _T Reduction	26
Output Current Sensing	12	Soft Transient Setting.....	26
Active Impedance Control Mode.....	13	Selecting Thermal Monitor Components	26
Current Control Mode and Thermal Balance	13	Tuning Procedure for ADP3207.....	27
Voltage Control Mode.....	13	Layout and Component Placement	28
Power-Good Monitoring.....	13	Outline Dimensions	30
Power-Up Sequence and Soft Start	14	Ordering Guide	30
Soft Transient	14		
Current-Limit, Short-Circuit, and Latch-Off Protection.....	15		
Changing VID on-the-Fly.....	15		

REVISION HISTORY

1/06—Revision 0: Initial Version

SPECIFICATIONS

VCC = 5 V, FBRTN = GND, EN = VCC, V_{VID} = 0.50 V to 1.5000 V, $\overline{\text{PSI}}$ = 1.05 V, DPRSLP = GND, $\overline{\text{DPRSTP}}$ = 1.05 V, LLSET = CSREF, T_A = 0°C to 100°C, unless otherwise noted.¹

Table 1.

Parameter	Symbol	Conditions	Min	Typ	Max	Units
VOLTAGE ERROR AMPLIFIER						
Output Voltage Range ²	V _{COMP}		0.85		4.0	V
VID DAC DC Accuracy	V _{FB} – V _{VID}	Measured at FB, relative to V _{VID} , see Figure 2	–8		+8	mV
	V _{FB(BOOT)}	Measured at end of start-up	1.192	1.200	1.208	V
Load Line Positioning DC Accuracy	V _{FB} – V _{VID}	Measured at FB, relative to V _{VID} , LLSET – CSREF = –80 mV	–78	–80	–82	mV
Differential Nonlinearity ²			–1		+1	LSB
Line Regulation	ΔV _{FB}	VCC = 4.75 V to 5.25 V		0.05		%
Input Bias Current	I _{FB}		–1		+1	μA
Output Current	I _{COMP}	FB forced to V _{OUT} – 3%		3		mA
Gain Bandwidth Product	GBW _(ERR)	COMP = FB		20		MHz
Slew Rate		C _{COMP} = 10 pF		25		V/μs
LLSET Input Voltage Range ²	V _{LLSET}	Relative to CSREF	–200		+200	mV
LLSET Input Bias Current	I _{LLSET}		–100		+100	nA
FBRTN Current	I _{FBRTN}			70	400	μA
VID DAC INPUTS						
Input Low Voltage	V _{IL}	VID _X		0.5	0.3	V
Input High Voltage	V _{IH}	VID _X	0.7	0.5		V
Input Current	I _{IN(VID)}			–1		μA
VID Transition Delay Time ²		VID change to FB change	400			ns
OSCILLATOR						
Frequency Range ²	f _{OSC}	$\overline{\text{PSI}}$ = $\overline{\text{DPRSTP}}$ = 1.05 V, DPRSLP = GND	0.3		3	MHz
Frequency Setting	f _{PHASE}	T _A = +25°C, V _{VID} = 1.2000 V, R _T = 215 kΩ	155	200	245	kHz
		T _A = +25°C, PWM3 = VCC, V _{VID} = 1.2000 V, R _T = 215 kΩ		300		
		T _A = +25°C, PWM2 = VCC, V _{VID} = 1.2000 V, R _T = 215 kΩ		600		
RAMPADJ Voltage	V _{RAMPADJ}	I _{RAMPADJ} = 60 μA	0.9	1.1	1.2	V
RAMPADJ Input Current Range ²	I _{RAMPADJ}	In normal mode	1	60	120	μA
		In shutdown, or in UVLO, RAMPADJ = 19 V	–1		+1	μA
RPM						
RT Voltage	V _{RT}	R _T = 215 kΩ to GND, V _{VID} = 1.4000 V	1.08	1.2	1.32	V
VRPM Reference Voltage	V _{VRPM}	I _{VRPM} = 0	.95	1	1.05	V
		I _{VRPM} = 120 μA	1.0	1.03	1.10	V
RRPM Output Current	I _{RRPM}	V _{VID} = 1.2 V, R _T = 215 kΩ		–5.5		μA
RPM Comparator Offset	V _{OS(RPM)}	V _{OS(RPM)} = V _{COMP} – V _{RRPM} , $\overline{\text{PSI}}$ = GND		1		mV
CURRENT-SENSE AMPLIFIER						
Offset Voltage	V _{OS(CSA)}	CSSUM – CSREF	–1.0		+1.0	mV
Input Bias Current	I _{BIAS(CSSUM)}		–50		+50	nA
Gain Bandwidth Product	GBW _(CSA)			10		MHz
Slew Rate		C _{CSCOMP} = 10 pF		10		V/μs
Input Common-Mode Range ²		CSSUM and CSREF	0		3.5	V
Output Voltage Range ²			0.05		2.0	V
Output Current	I _{CSCOMP}	Sinking Current		470		μA

ADP3207

Parameter	Symbol	Conditions	Min	Typ	Max	Units
CURRENT BALANCE AMPLIFIER						
Common Mode Range ²	$V_{SW(X)CM}$		-600		+200	mV
Input Resistance	$R_{SW(X)}$	$SW_X = 0\text{ V}$	30	40	60	k Ω
Input Current	$I_{SW(X)}$	$SW_X = 0\text{ V}$	3	4.5	6	μA
Input Current Matching	$\Delta I_{SW(X)}$	$SW_X = 0\text{ V}$	-5		+5	%
Zero Current Switching Threshold Voltage	$V_{DCM(SW1)}$	In DCM mode, DPRSLP = 3.3 V		-6		mV
Masked Off-Time	$t_{OFFMSKD}$	Measured from PWM turn-off		350		ns
CURRENT-LIMIT COMPARATOR						
ILIMIT Voltage	V_{ILIMIT}	$R_{ILIMIT} = 113\text{ k}\Omega$	1.65	1.7	1.75	V
ILIMIT Current	I_{ILIMIT}	$R_{ILIMIT} = 113\text{ k}\Omega$		-15		μA
Maximum ILIMIT Current ²			-60			μA
Current-Limit Threshold Voltage	V_{CL}	$V_{CSREF} - V_{CSCOMP}$, $R_{ILIMIT} = 113\text{ k}\Omega$, $\overline{PSI} = 1.05\text{ V}$	180	192	210	mV
		$V_{CSREF} - V_{CSCOMP}$, $R_{ILIMIT} = 113\text{ k}\Omega$, 1-phase, (PWM2 = VCC), $\overline{PSI} = \text{GND}$	180	192	210	mV
		$V_{CSREF} - V_{CSCOMP}$, $R_{ILIMIT} = 113\text{ k}\Omega$, 2-phase, (PWM3 = VCC), $\overline{PSI} = \text{GND}$	86	96	107	mV
		$V_{CSREF} - V_{CSCOMP}$, $R_{ILIMIT} = 113\text{ k}\Omega$, 3-phase, (neither PWM2 = VCC nor PWM3 = VCC), $\overline{PSI} = \text{GND}$	55	64	72	mV
SOFT START TIMER						
SS Current	I_{SS}	During start-up, $V_{SS} < 1.7\text{ V}$ In normal mode, $V_{SS} = 2.0\text{ V}$ In current limit, $V_{SS} = 2.0\text{ V}$	-10	-8 -48	-6	μA μA
SS Termination Threshold Voltage	$V_{TH(SS)}$	During start-up, SS is rising	1.5	2	2.5	μA
SS Clamp Voltage		In normal mode	1.6	1.7	1.8	V
Current-Limit Latch-Off Voltage	$V_{ILO(SS)}$	In current limit, SS is falling		2.9		V
			1.6	1.7	1.8	V
SOFT TRANSIENT CONTROL						
STSET Current	$I_{SOURCE(STSET)}$	Fast exit from deeper sleep, DPRSLP = 0 V, STSET = $V_{DAC} - 0.3\text{ V}$ Slow exit from deeper sleep, DPRSLP = 3.3 V, STSET = $V_{DAC} - 0.3\text{ V}$ Slow entry to deeper sleep, DPRSLP = 3.3 V, STSET = $V_{DAC} + 0.3\text{ V}$		-8 -2.5 +2.5		μA μA μA
Minimum STSET Capacitance ²	C_{STSET}		100			pF
Long Transient Threshold Accuracy	$V_{OS(SSMASK)}$	$V_{OS(SSMASK)} = V_{STSET} - V_{DAC}$		170		mV
SYSTEM INTERFACE CONTROL INPUTS						
\overline{PSI} and \overline{DPRSTP}						
Input Low Voltage	V_{IL}			0.5	0.3	V
Input High Voltage	V_{IH}		0.7	0.5		V
DPRSLP and EN						
Input Low Voltage	V_{IL}			1.3	1.0	V
Input High Voltage	V_{IH}		2.3	1.9		V
THERMAL THROTTLING CONTROL						
TTSense Voltage Range ²			0		5	V
TTSense VRTT Threshold Voltage		VCC = 5 V, TTSense is falling	2.45	2.5	2.55	V
TTSense VRTT Hysteresis			50	95		mV
TTSense Bias Current		TTSense = 2.6 V	-2		2	μA
VRTT Output Low Voltage	$V_{OL(VRTT)}$	$I_{VRTT(SINK)} = 400\text{ }\mu\text{A}$		10	500	mV
VRTT Output High Voltage	$V_{OH(VRTT)}$	$I_{VRTT(SOURCE)} = 400\text{ }\mu\text{A}$	4	5		V

Parameter	Symbol	Conditions	Min	Typ	Max	Units
POWER-GOOD COMPARATOR						
Undervoltage Threshold	$V_{CSREF(UV)}$	Relative to nominal DAC voltage	-240	-300	-360	mV
Overvoltage Threshold	$V_{CSREF(OV)}$	Relative to nominal DAC voltage	150	200	250	mV
Output Low Voltage	$V_{PWRGD(L)}$	$I_{PWRGD(SINK)} = 4 \text{ mA}$		85	250	mV
Output Leakage Current	I_{PWRGD}	$V_{PWRDG} = 5 \text{ V}$			3	μA
Power-Good Delay Timer						
PGDELAY Threshold	$V_{PGDELAY(TH)}$			2.9		V
PGDELAY Charge Current	$I_{PGDELAY}$	$V_{PGDELAY} = 2.0 \text{ V}$		1.9		μA
PGDELAY Discharge Resistance	$R_{PGDELAY}$	$V_{PGDELAY} = 0.2 \text{ V}$		550		Ω
Power-Good Masking Time				130		μs
Crowbar Threshold Voltage	$V_{CSREF(CB)}$	Relative to FBRTN	1.65	1.7	1.75	V
Reverse Voltage Detection Threshold	$V_{CSREF(RV)}$	Relative to FBRTN				
		CSREF is falling		-300	-350	mV
		CSREF is rising		-75	-10	mV
CLKEN OUTPUT						
Output Low Voltage		$I_{CLKEN(SINK)} = 4 \text{ mA}$		30	400	mV
Output Leakage Current		$V_{CLKEN} = 5 \text{ V}, V_{SS} = \text{GND}$			3	μA
OD/DCM OUTPUTS						
Output Low Voltage	V_{OL}	$I_{SINK} = 400 \mu\text{A}$		10	500	mV
Output High Voltage	V_{OH}	$I_{SOURCE} = 400 \mu\text{A}$	4	5		V
PWM OUTPUTS						
Output Low Voltage	$V_{OL(PWM)}$	$I_{PWM(SINK)} = 400 \mu\text{A}$		10	500	mV
Output High Voltage	$V_{OH(PWM)}$	$I_{PWM(SOURCE)} = 400 \mu\text{A}$	4.0	5		V
SUPPLY						
Supply Voltage Range	V_{CC}		4.5		5.5	V
Supply Current		Normal mode		4.2	10	mA
		EN = 0 V		190	300	μA
VCCOK Threshold Voltage	V_{CCOK}	VCC is rising		4.4	4.5	V
VCC UVLO Threshold Voltage	V_{CCUVLO}	VCC is falling	4.0	4.15		V
VCC Hysteresis ²				260		mV

¹ All limits at temperature extremes are guaranteed via correlation using standard Statistical Quality Control (SQC).

² Guaranteed by design or bench characterization, not production tested.

ABSOLUTE MAXIMUM RATINGS

Table 2.

Parameter	Rating
VCC	-0.3 V to +6 V
FBRTN	-0.3 V to +0.3 V
SW1 to SW3	-10 V to +25 V
RAMPADJ (In Shutdown)	-0.3 V to +25 V
All Other Inputs and Outputs	-0.3 V to VCC + 0.3 V
Storage Temperature	-65°C to +150°C
Operating Ambient Temperature Range	0°C to 100°C
Operating Junction Temperature	125°C
Thermal Impedance (θ_{JA})	98°C/W
Lead Temperature	
Soldering (10 sec)	300°C
Infrared (15 sec)	260°C

Stresses above those listed under Absolute Maximum Ratings may cause permanent damage to the device. This is a stress rating only; functional operation of the device at these or any other conditions above those indicated in the operational section of this specification is not implied. Exposure to absolute maximum rating conditions for extended periods may affect device reliability.

Absolute maximum ratings apply individually only, not in combination. Unless otherwise specified, all other voltages are referenced to GND.

ESD CAUTION

ESD (electrostatic discharge) sensitive device. Electrostatic charges as high as 4000 V readily accumulate on the human body and test equipment and can discharge without detection. Although this product features proprietary ESD protection circuitry, permanent damage may occur on devices subjected to high energy electrostatic discharges. Therefore, proper ESD precautions are recommended to avoid performance degradation or loss of functionality.



PIN CONFIGURATION AND FUNCTION DESCRIPTIONS

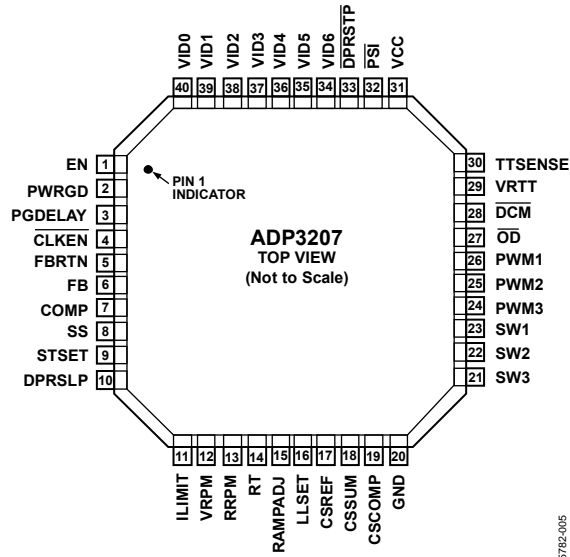

Figure 5. Pin Configuration

Table 3. Pin Function Descriptions

Pin No.	Mnemonic	Description
1	EN	Power Supply Enable Input. Pulling this pin to GND disables the PWM outputs and pulls the PWRGD output low.
2	PWRGD	Power-Good Output. Open drain output that signals when the output voltage is outside of the proper operating range. The pull-high voltage on this pin cannot be higher than VCC.
3	PGDELAY	Power-Good Delay Setting Input. A capacitor between this pin and GND sets the power-good delay time.
4	CLKEN	Clock Enable Output. The pull-high voltage on this pin cannot be higher than VCC.
5	FBRTN	Feedback Return. VID DAC and error amplifier reference for remote sensing of the output voltage.
6	FB	Feedback Input. Error amplifier input for remote sensing of the output voltage.
7	COMP	Error Amplifier Output and Compensation Point.
8	SS	Soft-Start Delay Setting Input. An external capacitor connected between this pin and GND sets the soft-start ramp-up time and the current-limit latch-off delay time.
9	STSET	Soft Transient Slew Rate Timing Input. A capacitor from this pin to GND sets the slew rate of the output voltage when transitioning between the boot voltage and the programmed VID voltage, and when transitioning between active mode and deeper sleep mode.
10	DPRSLP	Deeper Sleep Control Input.
11	ILIMIT	Current-Limit Setpoint. An external resistor from this pin to GND sets the current-limit threshold of the converter.
12	VRPM	RPM Mode Reference Voltage Output.
13	RRPM	RPM Mode Timing Control Input. A resistor between this pin and VRPM sets the RPM mode turn-on threshold voltage.
14	RT	Multiphase Frequency Setting Input. An external resistor connected between this pin and GND sets the oscillator frequency of the device when operating in multiphase PWM mode.
15	RAMPADJ	PWM Ramp Current Input. An external resistor from the converter input voltage to this pin sets the internal PWM ramp.
16	LLSET	Output Load Line Programming Input. The center point of a resistor divider between CSREF and CSCOMP is connected to this pin to set the load line slope.
17	CSREF	Current-Sense Reference Voltage Input. The voltage on this pin is used as the reference for the current-sense amplifier and the power-good and crowbar functions. This pin should be connected to the common point of the output inductors.
18	CSSUM	Current-Sense Summing Node. External resistors from each switch node to this pin sum the inductor currents together to measure the total output current.
19	CSCOMP	Current-Sense Compensation Point. A resistor and capacitor from this pin to CSSUM determine the gain of the current-sense amplifier and the positioning loop response time.
20	GND	Ground. All internal biasing and the logic output signals of the device are referenced to this ground.
21 to 23	SW3 to SW1	Current Balance Inputs. Inputs for measuring the current level in each phase. The SW pins of unused phases should be left open.

Pin No.	Mnemonic	Description
24 to 26	PWM3 to PWM1	Logic-Level PWM Outputs. Each output is connected to the input of an external MOSFET driver such as the ADP3419. Connecting the PWM2 and/or PWM3 outputs to VCC causes that phase to turn off, allowing the ADP3207 to operate as a 1-, 2-, or 3-phase controller.
27	$\overline{\text{OD}}$	Multiphase Output Disable Logic Output. This pin is actively pulled low when the ADP3207 enters single-phase mode or during shutdown. Connect this pin to the SD inputs of the Phase-2 and Phase-3 MOSFET drivers.
28	$\overline{\text{DCM}}$	Discontinuous Current Mode Enable Output. This pin is actively pulled low when the single-phase inductor current crosses zero.
29	VRTT	Voltage Regulator Thermal Throttling Logic Output. This pin goes high if the temperature at the monitoring point connected to TTSENSE exceeds the programmed VRTT temperature threshold.
30	TTSENSE	Thermal Throttling Sense Input and OVP Disable. The center point of a resistor divider (where the lower resistor is an NTC thermistor) between VCC and GND is connected to this pin to remotely sense the temperature at the desired thermal monitoring point. Grounding TTSENSE disables OVP function.
31	VCC	Supply Voltage for the Device.
32	$\overline{\text{PSI}}$	Power State Indicator Input. Pulling this pin to GND forces the ADP3207 to operate in single-phase mode.
33	$\overline{\text{DPRSTP}}$	Deeper Stop Control Input.
34 to 40	VID6 to VIDO	Voltage Identification DAC Inputs. When in normal operation mode, the DAC output programs the FB regulation voltage from 0.3 V to 1.5 V (see Table 6).

TYPICAL PERFORMANCE CHARACTERISTICS

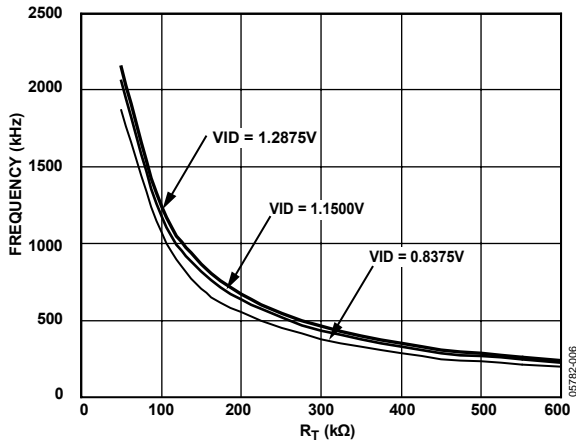

Figure 6. Master Clock Frequency vs. R_T

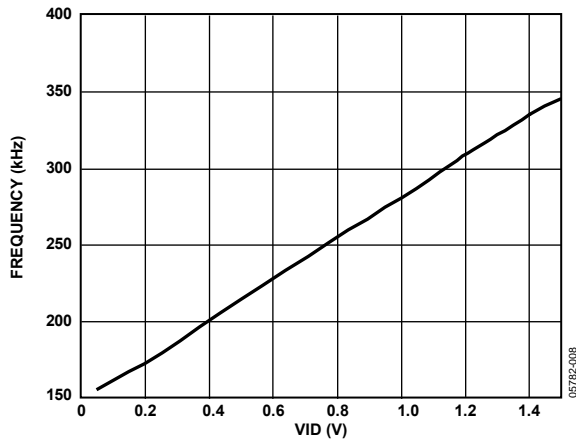
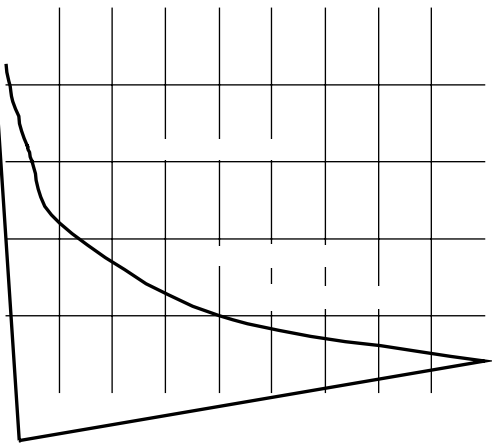

Figure 7. Master Clock vs. VID

THEORY OF OPERATION

The ADP3207 combines a multimode PWM/RPM (ramp pulse modulated) control with multiphase logic outputs for use in 1-, 2-, and 3-phase synchronous buck CPU core supply power converters. The internal 7-bit VID DAC conforms to Intel IMVP-6 specifications. Multiphase operation is important for producing the high currents and low voltages demanded by today's microprocessors. Handling high currents in a single-phase converter puts high thermal stress on the system components such as the inductors and MOSFETs.

The multimode control of the ADP3207 ensures a stable high performance topology for:

- Balancing currents and thermals between phases
- High speed response at the lowest possible switching frequency and minimal output decoupling
- Minimizing thermal switching losses due to lower frequency operation
- Tight load line regulation and accuracy
- High current output by supporting up to 3-phase operation
- Reduced output ripple due to multiphase ripple cancellation
- High power conversion efficiency both at heavy load and light load
- PC board layout noise immunity
- Ease of use and design due to independent component selection
- Flexibility in operation by allowing optimization of design for low cost or high performance

NUMBER OF PHASES

The number of operational phases and their phase relationship is determined by internal circuitry that monitors the PWM outputs. Normally, the ADP3207 operates as a 3-phase controller. For 2-phase operation, the PWM3 pin is connected to VCC 5 V programs, and for 1-phase operation, the PWM3 and PWM2 pins are connected to VCC 5 V programs.

When the ADP3207 is initially enabled, the controller sinks 50 μ A on the PWM2 and PWM3 pins. An internal comparator checks the voltage of each pin against a high threshold of 3 V. If the pin voltage is high due to pull up to the VCC 5 V rail, then the phase is disabled. The phase detection is made during the first three clock cycles of the internal oscillator. After phase detection, the 50 μ A current sink is removed. The pins that are not connected to the VCC 5 V rail function as normal PWM outputs. The pins that are connected to VCC enter into high impedance state.

The PWM outputs are 5 V logic-level signals intended for driving external gate drivers such as the ADP3419. Because each phase is monitored independently, operation approaching 100% duty cycle is possible. In addition, more than one output can operate at a time to allow overlapping phases.

OPERATION MODES

For ADP3207, the number of phases can be selected by the user as described in the Number of Phases section, or they can dynamically change based on system signals to optimize the power conversion efficiency at heavy and light CPU loads.

During a VID transient or at a heavy load condition, indicated by DPRSLP going low and $\overline{\text{PSI}}$ going high, the ADP3207 runs in full-phase mode. All user selected phases operate in interleaved PWM mode that results in minimal V_{CORE} ripple and best transient performance. While in light load mode, indicated by either $\overline{\text{PSI}}$ going low or DPRSLP going high, only Phase 1 of ADP3207 is in operation to maximize power conversion efficiency.

In addition to the change of phase number, the ADP3207 dynamically changes operation modes. In multiphase operation, the ADP3207 runs in PWM mode, with switching frequency controlled by the master clock. In single-phase mode based on $\overline{\text{PSI}}$ signal, the ADP3207 switches to RPM mode, where the switching frequency is no longer controlled by the master clock, but by the ripple voltage appearing on the COMP pin. The PWM1 pin is set to high each time the COMP pin voltage rises to a limit determined by the VID voltage and programmed by the external resistor connected between Pin VRPM and Pin RRPm. In single-phase mode based on the DPRSLP signal, the ADP3207 runs in RPM mode, with the synchronous rectifier (low-side) MOSFETs of Phase 1 being controlled by the DCM pin to prevent any reverse inductor current. Thus, the switch frequency varies with the load current, resulting in maximum power conversion efficiency in deeper sleep mode of CPU operation. In addition, during any VID transient, system transient (entry/exit of deeper sleep), or current limit, the ADP3207 goes into full phase mode, regardless of DPRSLP and $\overline{\text{PSI}}$ signals, eliminating current stress to Phase 1.

Table 4 summarizes how the ADP3207 dynamically changes phase number and operation modes based on system signals and operating conditions.

Table 4. Phase Number and Operation Modes

$\overline{\text{PSI}}$	DPRSLP	VID Transient Period ¹	Hit Current Limit	No. of Phases Selected by User	No. of Phases in Operation	Operation Mode
DNC ²	DNC ²	Yes	DNC ²	N 3, 2, or 1	N	PWM, CCM ³ only
1	0	No	DNC ²	N 3, 2, or 1	N	PWM, CCM ³ only
0	0	No	No	DNC ²	Phase 1 only	RPM, CCM ³ only
0	0	No	Yes	DNC ²	N	PWM, CCM ³ only
DNC ²	1	No	No	DNC ²	Phase 1 only	RPM, automatic CCM ³ /DCM ⁴
DNC ²	1	No	Yes	DNC ²	N	PWM, CCM ³ only

¹ VID transient period is the time period following any VID change, including entrance and exit of deeper sleep mode. The duration of VID transient period is the same as that of PWRGD masking time.

² DNC means do not care.

³ CCM means continuous conduction mode

⁴ DCM means discontinuous conduction mode.

SWITCH FREQUENCY SETTING

Master Clock Frequency for PWM Mode

The clock frequency of the ADP3207 is set by an external resistor connected from the RT pin to ground. The frequency varies with the VID voltage: the lower the VID voltage, the lower the clock frequency. The variation of clock frequency with VID voltage makes V_{CORE} ripple remain constant and improves power conversion efficiency at a lower VID voltage. Figure 6 shows the relationship between clock frequency and VID voltage, parameterized by RT resistance.

To determine the switching frequency per phase, the clock is divided by the number of phases in use. If PWM3 is pulled up to VCC, then the master clock is divided by 2 for the frequency of the remaining phases. If PWM2 and PWM3 are pulled up to VCC, then the switching frequency of a Phase 1 equals the master clock frequency. If all phases are in use, divide by 3.

Switching Frequency for RPM Mode–Phase 1

When ADP3207 operates in single-phase RPM mode, its switching frequency is not controlled by the master clock, but by the ripple voltage on the COMP pin. The PWM1 pin is set high each time the COMP pin voltage rises to a voltage limit determined by the VID voltage and the external resistance connected between Pin VRPM and Pin RRPm. Whenever PWM1 pin is high, an internal ramp signal rises at a slew rate programmed by the current flowing into the RAMPADJ pin. Once this internal ramp signal hits the COMP pin voltage, the PWM1 pin is reset to low.

In continuous current mode, the switching frequency of RPM operation is maintained almost constantly. While in discontinuous current mode, the switching frequency reduces with the load current.

OUTPUT VOLTAGE DIFFERENTIAL SENSING

The ADP3207 combines differential sensing with a high accuracy, VID DAC, precision REF output and a low offset error amplifier to meet the rigorous accuracy requirement of the Intel IMVP-6 specification. In steady-state, the VID DAC and error amplifier meet the worst-case error specification of ± 10 mV over the full operating output voltage and temperature range.

The CPU core output voltage is sensed between the FB and FBRTN pins. Connect FB through a resistor to the positive regulation point, usually the VCC remote sense pin of the microprocessor. Connect FBRTN directly to the negative remote sense point, the VSS sense point of the CPU. The internal VID DAC and precision voltage reference are referenced to FBRTN, and have a maximum current of 200 μA to guarantee accurate remote sensing.

OUTPUT CURRENT SENSING

The ADP3207 provides a dedicated current-sense amplifier (CSA) to monitor the total output current of the converter for proper voltage positioning vs. load current, and for current-limit detection. Sensing the load current being delivered to the load is inherently more accurate than detecting peak current or sampling the current across a sense element, such as the low-side MOSFET. The current-sense amplifier can be configured several ways depending on system requirements.

- Output inductor ESR sensing without use of a thermistor for lowest cost
- Output inductor ESR sensing with use of a thermistor that tracks inductor temperature to improve accuracy
- Discrete resistor sensing for highest accuracy

The positive input of the CSA is connected to the CSREF pin, which is connected to the output voltage. At the negative input CSSUM pin of the CSA, signals from the sensing element (that is, in case of inductor RDC sensing, signals from the switch node side of the output inductors) are summed together by using series summing resistors. The feedback resistor between CSCOMP and CSSUM sets the gain of the current-sense amplifier, and a filter capacitor is placed in parallel with this resistor. The current information is then given as the voltage difference between CSREF and CSCOMP. This signal is used internally as a differential input for the current-limit comparator.

An additional resistor divider connected between CSREF and CSCOMP with the midpoint connected to LLSET can be used to set the load line required by the microprocessor specification. The current information for load line setting is then given as the voltage difference of CSREF – LLSET. The configuration in the previous paragraph makes it possible for the load line slope to be set independently of the current-limit threshold. In the event that the current-limit threshold and load line do not have to be independent, the resistor divider between CSREF and CSCOMP can be omitted and the CSCOMP pin can be connected directly to LLSET. To disable voltage positioning entirely (that is, to set no load line), tie LLSET to CSREF.

To provide the best accuracy for current sensing, the CSA is designed to have a low offset input voltage. In addition, the sensing gain is set by an external resistor ratio.

ACTIVE IMPEDANCE CONTROL MODE

To control the dynamic output voltage droop as a function of the output current, the signal proportional to the total output current is converted to a voltage that appears between CSREF and LLSET. This voltage can be scaled to equal the droop voltage, which is calculated by multiplying the droop impedance of the regulator with the output current. The droop voltage is then used as the control voltage of the PWM regulator. The droop voltage is subtracted from the DAC reference output voltage and determines the voltage positioning setpoint. The setup results in an enhanced feed-forward response.

CURRENT CONTROL MODE AND THERMAL BALANCE

The ADP3207 has individual inputs for monitoring the current in each phase. The phase current information is combined with an internal ramp to create a current balancing feedback system that is optimized for initial current accuracy and dynamic thermal balance. The current balance information is independent of the total inductor current information used for voltage positioning described in the Active Impedance Control Mode section.

The magnitude of the internal ramp can be set so the transient response of the system becomes optimal. The ADP3207 also monitors the supply voltage to achieve feed-forward control whenever the supply voltage changes. A resistor connected from the power input voltage rail to the RAMPADJ pin determines the slope of the internal PWM ramp. Detailed information about programming the ramp is given in the Ramp Resistor Selection section.

External resistors can be placed in series with the SW2 and SW3 pins to create an intentional current imbalance, if desired. Such a condition can exist when one phase has better cooling and supports higher currents than the other phase. Resistor RSW2 and Resistor RSW3 (see the typical application circuit in Figure 10) can be used to adjust thermal balance. It is recommended to add these resistors during the initial design to make sure placeholders are provided in the layout.

To increase the current in any given phase, users should make RSW for that phase larger (that is, make $RSW = 0$ for the hottest phase and do not change it during balance optimization). Increasing RSW to 500 Ω makes a substantial increase in phase current. Increase each RSW value by small amounts to achieve thermal balance starting with the coolest phase.

When current limit is reached, the ADP3207 switches to full-phase PWM mode, regardless of System Signal DRPSLP and PSI, to avoid inrush current stress to the Phase 1 power stage.

VOLTAGE CONTROL MODE

A high gain bandwidth error amplifier is used for the voltage-mode control loop. The noninverting input voltage is set via the 7-bit VID DAC. The VID codes are listed in Table 6. The noninverting input voltage is offset by the droop voltage as a function of current, commonly known as active voltage positioning. The output of the error amplifier is the COMP pin, which sets the termination voltage for the internal PWM ramps.

The negative input, FB, is tied to the output sense location through a resistor, RB, for sensing and controlling the output voltage at the remote sense point. The main loop compensation is incorporated in the feedback network connected between FB and COMP.

POWER-GOOD MONITORING

The power-good comparator monitors the output voltage via the CSREF pin. The PWRGD pin is an open drain output that can be pulled up through an external resistor to a voltage rail that is not necessarily the same VCC voltage rail of the controller. Logic high level indicates that the output voltage is within the voltage limits defined by a window around the VID voltage setting. PWRGD goes low when the output voltage is outside of that window.

Following the IMVP-6 specification, PWRGD window is defined as -300 mV below and $+200$ mV above the actual VID DAC output voltage. For any DAC voltage below 300 mV, only the upper limit of the PWRGD window is monitored. To prevent false alarm, the power-good circuit is masked during various system transitions, including any VID change and entrance/exit out of deeper sleep. The duration of the PWRGD mask is set by an internal timer to be about 100 μ s. In conditions where a larger than 200 mV voltage drop occurs during deeper sleep entry or slow deeper sleep exit, the duration of PWRGD masking is extended by an internal logic circuit.

POWER-UP SEQUENCE AND SOFT START

The power-on ramp-up time of the output voltage is set with a capacitor tied from the SS pin to GND. The capacitance on the SS pin also determines the current-limit latch-off time as explained in the Soft Transient section. The whole power-up sequence, including soft start, is illustrated

Table 5 lists the source/sink current on the STSET pin for various transitions. By charging/discharging the external capacitor on the STSET pin, users actually program the voltage slew rate on the STSET pin, and consequently, on the V_{CORE} output. For example, a 750 pF STSET capacitor leads to a 10 mV/s V_{CORE} slew rate appropriate for a fast exit from deeper sleep, and to a ± 3.3 mV/ μ s V_{CORE} slew rate for a slow entry to, or exit from, deeper sleep.

Table 5. Source/Sink Current of STSET

VID Transient	System Signals		STSET Current
	DPRSLP	DPRSTP	
Entrance to Deeper Sleep	HIGH	DNC ¹	-2.5 μ A
Fast Exit from Deeper Sleep	LOW	DNC ¹	+7.5 μ A
Slow Exit from Deeper Sleep	HIGH	HIGH	+2.5 μ A
Transient from V_{BOOT} to VID	DNC ¹	DNC ¹	± 2.5 μ A

¹ Do not care.

CURRENT-LIMIT, SHORT-CIRCUIT, AND LATCH-OFF PROTECTION

The ADP3207 compares the differential output of a current-sense amplifier to a programmable current-limit setpoint to provide current-limiting function. The nominal voltage on the ILIMIT pin is 1.7 V. The current-limit threshold is set with a resistor connected from the ILIMIT pin to GND. In multiphase normal operating mode, the ILIMIT is internally scaled by using a trimmed 12 k Ω resistor to give a current-limit threshold of 10 mV for each μ A of ILIMIT current. For single-phase operation, the current-limit threshold is scaled down even further. The scaling factor is the user selected number of phases. For example, a 3-phase design scales the current-limit threshold to 3.3 mV/ μ A referred to single-phase operation; a 2-phase design scales the current-limit threshold to 5 mV/ μ A also referred to single-phase operation. During any mode of operation, if the voltage difference between CSREF and CSCOMP rises above the current-limit threshold, the internal current-limit amplifier takes control over the internal COMP voltage to maintain an average output current equal to the set limit level.

During start-up when the output voltage is below 200 mV, a secondary current limit is activated. This is necessary because the voltage swing on CSCOMP cannot extend below ground. The secondary current-limit circuit clamps the internal COMP voltage and sets the internal compensation ramp termination voltage at 1.5 V level. The clamp actually limits voltage drop across the low side MOSFETs through the current balance circuitry.

An inherent per phase current limit protects individual phases in case one or more phases stop functioning because of a faulty component. This limit is based on the maximum normal-mode COMP voltage.

After a current limit is hit, or following a PWRGD failure, the SS pin is discharged by an internal sink current of 2 μ A. A comparator monitors the SS pin voltage and shuts off the controller when the voltage drops below about 1.65 V. Because voltage ramp (2.9 V - 1.65 V = 1.25 V) and discharge current (2 μ A) are internally fixed, current-limit latch-off delay time can be set by selecting the external SS pin capacitor.

The controller keeps cycling the phases during latch-off delay time. If current overload is removed and PWRGD is recovered before the 1.65 V threshold is reached, then the controller resumes normal operation, and the SS pin voltage recovers to 2.9 V clamp level.

The latch-off can be reset by removing and reapplying VCC, or by recycling the EN pin low and high for a short time. To disable the current-limit latch-off function, an external pull-up resistor can be tied from the SS pin to the VCC rail. The pull-up current has to override the 2 μ A sink current of the SS pin to prevent the SS capacitor from discharging down to the 1.65 V latch-off threshold.

CHANGING VID ON-THE-FLY

The ADP3207 is designed to track dynamically changing VID code. As a result, the converter output voltage, that is, the CPU VCC voltage, can change without the need to reset either the controller or the CPU. This concept is commonly referred to as VID on-the-fly (VID OTF) transient. A VID-OTF can occur either under light load or heavy load conditions. The processor signals the controller by changing the VID inputs in LSB incremental steps from the start code to the finish code. The change can be either upwards or downwards steps.

When a VID input changes state, the ADP3207 detects the change but ignores the new code for a minimum of time of 400 ns. This keep out is required to prevent reaction to false code that can occur by a skew in the VID code while the 7-bit VID input code is in transition. Additionally, the VID change triggers a PWRGD masking timer to prevent a PWRGD failure. Each VID change resets and retriggers the internal PWRGD masking timer. As listed in Table 5, during any VID transient, the ADP3207 forces a multiphase PWM mode regardless of system input signals.

ADP3207

OUTPUT CROWBAR

To protect the CPU load and output components of the converter, the PWM outputs are driven low, \overline{DCM} and \overline{OD} are driven high (that is, commanded to turn on the low-side MOSFETs of all phases) when the output voltage exceeds an OVP threshold of 1.7 V as specified by IMVP-6.

Turning on the low-side MOSFETs discharges the output capacitor as soon as reverse current builds up in the inductors. If the output overvoltage is due to a short of the high-side MOSFET, then this crowbar action current limits the input supply or causes the input rail fuse to blow, protecting the microprocessor from destruction.

Once overvoltage protection (OVP) is triggered, the ADP3207 is latched off. The latch-off function can be reset by removing and reapplying VCC, or by recycling EN low and high for a short time. OVP can be disabled by grounding the TTSENSE pin. The OVP comparator monitors the output voltage via the CSREF pin.

REVERSE VOLTAGE PROTECTION

Very large reverse currents in inductors can cause negative V_{CORE} voltage, which is harmful to the CPU and other output components. ADP3207 provides reverse voltage protection (RVP) function without additional system cost. The V_{CORE} voltage is monitored through the CSREF pin. Any time the CSREF pin voltage is below -300 mV, the ADP3207 triggers its RVP function by disabling all PWM outputs and setting both \overline{DCM} and \overline{OD} pins low. Thus, all the MOSFETs are turned off. The reverse inductor current can be quickly reset to zero by dumping the energy built up in the inductor into the input dc voltage source via the forward-biased body diode of the high-side MOSFETs. The RVP function is terminated when the CSREF pin voltage returns above -100 mV.

Occasionally, overvoltage crowbar protection results in negative V_{CORE} voltage, because turn-on of all low-side MOSFETs leads to very large reverse inductor current. To prevent damage of the CPU by negative voltage, ADP3207 keeps its RVP monitoring function alive even after OVP latch-off. During OVP latch-off, if the CSREF pin voltage drops below -300 mV, then all low-side

MOSFETs are turned off by setting both \overline{DCM} and \overline{OD} low. \overline{DCM} and \overline{OD} pins are set high again when CSREF voltage recovers above -100 mV.

OUTPUT ENABLE AND UVLO

The VCC supply voltage to the controller must be higher than the UVLO upper threshold, and the EN pin must be higher than its logic threshold so the ADP3207 can begin switching. If the VCC voltage is less than the UVLO threshold, or the EN pin is logic low, then the ADP3207 is in shutdown. In shutdown, the controller holds the PWM outputs at ground, shorts the SS pin and PGDELAY pin capacitors to ground, and drives \overline{DCM} and \overline{OD} pins low.

Proper power supply sequencing during start-up and shutdown of the ADP3207 must be adhered to. All input pins must be at ground prior to applying or removing VCC. All output pins should be left in high impedance state while VCC is off.

THERMAL THROTTLING CONTROL

The ADP3207 includes a thermal monitoring circuit to detect if the temperature of the variable resistor (VR) has exceeded a user-defined thermal throttling threshold. The thermal monitoring circuit requires an external resistor divider connected between the VCC pin and GND. The divider consists of an NTC thermistor and a resistor. To generate a voltage that is proportional to temperature, the midpoint of the divider is connected to the TTSENSE pin. Whenever the temperature trips the set alarm threshold, an internal comparator circuit compares the TTSENSE voltage to a half VCC threshold and outputs a logic level signal at the VRTT output. The VRTT output is designed to drive an external transistor that, in turn, provides the high current, open drain \overline{VRTT} signal that is required by the IMVP-6 specification. When the temperature is around the set alarm point, the internal VRTT comparator has a hysteresis of about 100 mV to prevent high frequency oscillation of VRTT. The TTSENSE pin also serves the function of disabling OVP. In extreme heat, users should make sure that the TTSENSE pin voltage remains above 1 V if OVP is desired.

Table 6. VID Code Table

VID6	VID5	VID4	VID3	VID2	VID1	VID0	OUTPUT	VID6	VID5	VID4	VID3	VID2	VID1	VID0	OUTPUT
0	0	0	0	0	0	0	1.5000 V	0	1	1	0	0	1	1	0.8625 V
0	0	0	0	0	0	1	1.4875 V	0	1	1	0	1	0	0	0.8500 V
0	0	0	0	0	1	0	1.4750 V	0	1	1	0	1	0	1	0.8375 V
0	0	0	0	0	1	1	1.4625 V	0	1	1	0	1	1	0	0.8250 V
0	0	0	0	1	0	0	1.4500 V	0	1	1	0	1	1	1	0.8125 V
0	0	0	0	1	0	1	1.4375 V	0	1	1	1	0	0	0	0.8000 V
0	0	0	0	1	1	0	1.4250 V	0	1	1	1	0	0	1	0.7875 V
0	0	0	0	1	1	1	1.4125 V	0	1	1	1	0	1	0	0.7750 V
0	0	0	1	0	0	0	1.4000 V	0	1	1	1	0	1	1	0.7625 V
0	0	0	1	0	0	1	1.3875 V	0	1	1	1	1	0	0	0.7500 V
0	0	0	1	0	1	0	1.3750 V	0	1	1	1	1	0	1	0.7375 V
0	0	0	1	0	1	1	1.3625 V	0	1	1	1	1	1	0	0.7250 V
0	0	0	1	1	0	0	1.3500 V	0	1	1	1	1	1	1	0.7125 V
0	0	0	1	1	0	1	1.3375 V	1	0	0	0	0	0	0	0.7000 V
0	0	0	1	1	1	0	1.3250 V	1	0	0	0	0	0	1	0.6875 V
0	0	0	1	1	1	1	1.3125 V	1	0	0	0	0	1	0	0.6750 V
0	0	1	0	0	0	0	1.3000 V	1	0	0	0	0	1	1	0.6625 V
0	0	1	0	0	0	1	1.2875 V	1	0	0	0	1	0	0	0.6500 V
0	0	1	0	0	1	0	1.2750 V	1	0	0	0	1	0	1	0.6375 V
0	0	1	0	0	1	1	1.2625 V	1	0	0	0	1	1	0	0.6250 V
0	0	1	0	1	0	0	1.2500 V	1	0	0	0	1	1	1	0.6125 V
0	0	1	0	1	0	1	1.2375 V	1	0	0	1	0	0	0	0.6000 V
0	0	1	0	1	1	0	1.2250 V	1	0	0	1	0	0	1	0.5875 V
0	0	1	0	1	1	1	1.2125 V	1	0	0	1	0	1	0	0.5750 V
0	0	1	1	0	0	0	1.2000 V	1	0	0	1	0	1	1	0.5625 V
0	0	1	1	0	0	1	1.1875 V	1	0	0	1	1	0	0	0.5500 V
0	0	1	1	0	1	0	1.1750 V	1	0	0	1	1	0	1	0.5375 V
0	0	1	1	0	1	1	1.1625 V	1	0	0	1	1	1	0	0.5250 V
0	0	1	1	1	0	0	1.1500 V	1	0	0	1	1	1	1	0.5125 V
0	0	1	1	1	0	1	1.1375 V	1	0	1	0	0	0	0	0.5000 V
0	0	1	1	1	1	0	1.1250 V	1	0	1	0	0	0	1	0.4875 V
0	0	1	1	1	1	1	1.1125 V	1	0	1	0	0	1	0	0.4750 V
0	1	0	0	0	0	0	1.1000 V	1	0	1	0	0	1	1	0.4625 V
0	1	0	0	0	0	1	1.0875 V	1	0	1	0	1	0	0	0.4500 V
0	1	0	0	0	1	0	1.0750 V	1	0	1	0	1	0	1	0.4375 V
0	1	0	0	0	1	1	1.0625 V	1	0	1	0	1	1	0	0.4250 V
0	1	0	0	1	0	0	1.0500 V	1	0	1	0	1	1	1	0.4125 V
0	1	0	0	1	0	1	1.0375 V	1	0	1	1	0	0	0	0.4000 V
0	1	0	0	1	1	0	1.0250 V	1	0	1	1	0	0	1	0.3875 V
0	1	0	0	1	1	1	1.0125 V	1	0	1	1	0	1	0	0.3750 V
0	1	0	1	0	0	0	1.0000 V	1	0	1	1	0	1	1	0.3625 V
0	1	0	1	0	0	1	0.9875 V	1	0	1	1	1	0	0	0.3500 V
0	1	0	1	0	1	0	0.9750 V	1	0	1	1	1	0	1	0.3375 V
0	1	0	1	0	1	1	0.9625 V	1	0	1	1	1	1	0	0.3250 V
0	1	0	1	1	0	0	0.9500 V	1	0	1	1	1	1	1	0.3125 V
0	1	0	1	1	0	1	0.9375 V	1	1	0	0	0	0	0	0.3000 V
0	1	0	1	1	1	0	0.9250 V	1	1	0	0	0	0	1	0.2875 V
0	1	0	1	1	1	1	0.9125 V	1	1	0	0	0	1	0	0.2750 V
0	1	1	0	0	0	0	0.9000 V	1	1	0	0	0	1	1	0.2625 V
0	1	1	0	0	0	1	0.8875 V	1	1	0	0	1	0	0	0.2500 V
0	1	1	0	0	1	0	0.8750 V	1	1	0	0	1	0	1	0.2375 V

ADP3207

VID6	VID5	VID4	VID3	VID2	VID1	VID0	OUTPUT
1	1	0	0	1	1	0	0.2250 V
1	1	0	0	1	1	1	0.2125 V
1	1	0	1	0	0	0	0.2000 V
1	1	0	1	0	0	1	0.1875 V
1	1	0	1	0	1	0	0.1750 V
1	1	0	1	0	1	1	0.1625 V
1	1	0	1	1	0	0	0.1500 V
1	1	0	1	1	0	1	0.1375 V
1	1	0	1	1	1	0	0.1250 V
1	1	0	1	1	1	1	0.1125 V
1	1	1	0	0	0	0	0.1000 V
1	1	1	0	0	0	1	0.0875 V
1	1	1	0	0	1	0	0.0750 V

VID6	VID5	VID4	VID3	VID2	VID1	VID0	OUTPUT
1	1	1	0	0	1	1	0.0625 V
1	1	1	0	1	0	0	0.0500 V
1	1	1	0	1	0	1	0.0375 V
1	1	1	0	1	1	0	0.0250 V
1	1	1	0	1	1	1	0.0125 V
1	1	1	1	0	0	0	0.0000 V
1	1	1	1	0	0	1	0.0000 V
1	1	1	1	0	1	0	0.0000 V
1	1	1	1	0	1	1	0.0000 V
1	1	1	1	1	0	0	0.0000 V
1	1	1	1	1	0	1	0.0000 V
1	1	1	1	1	1	0	0.0000 V
1	1	1	1	1	1	1	0.0000 V

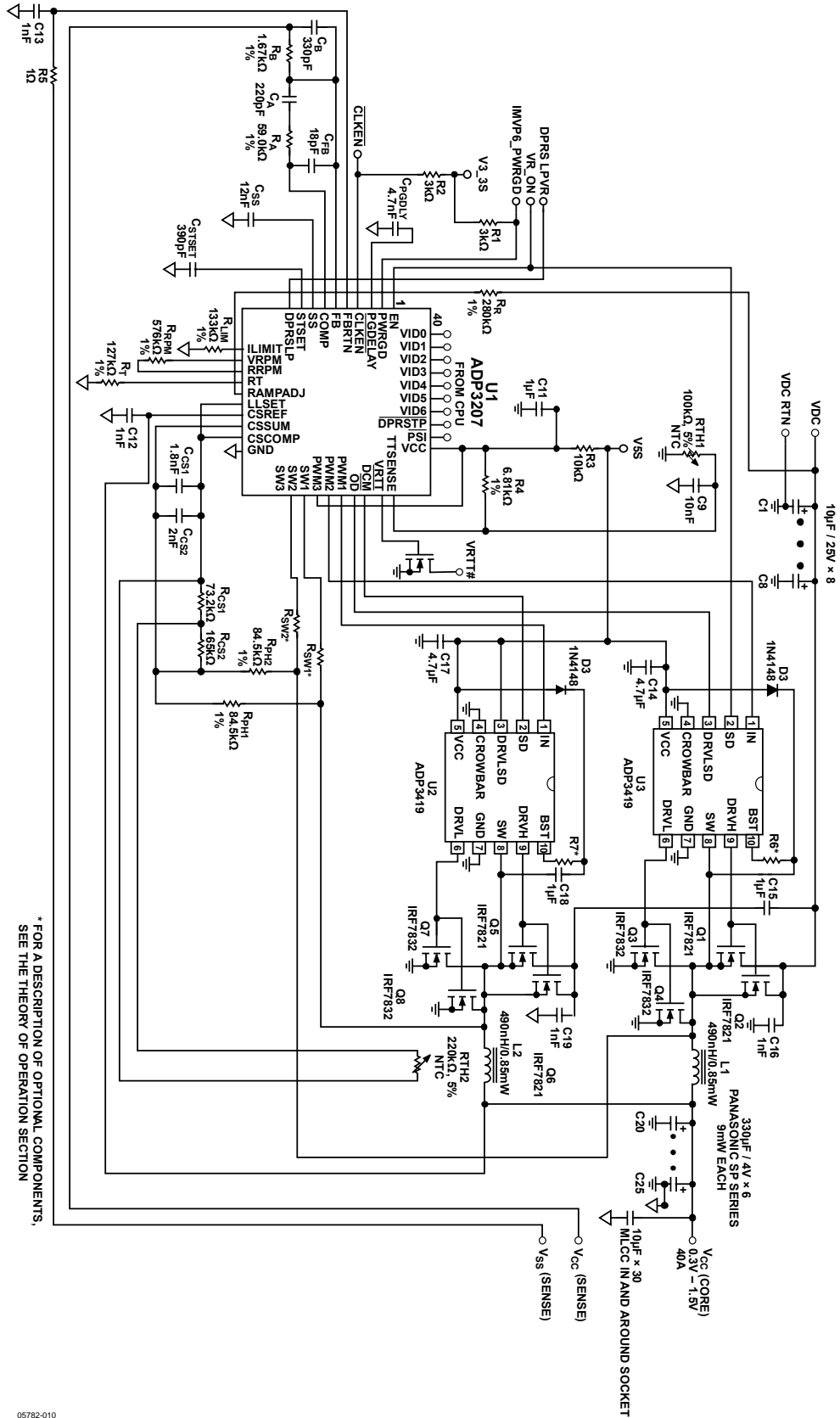

* FOR A DESCRIPTION OF OPTIONAL COMPONENTS, SEE THE THEORY OF OPERATION SECTION.

05782-010

Figure 10. Typical 2-Phase Application Circuit

APPLICATION INFORMATION

The design parameters for a typical Intel IMVP6-compliant CPU Core VR application are as follows:

- Maximum input voltage (V_{INMAX}) = 19 V
- Minimum input voltage (V_{INMIN}) = 7 V
- Output voltage by VID setting (V_{VID}) = 1.150 V
- Maximum output current (I_O) = 44 A
- Load line slope (R_O) = 2.1 m Ω
- Maximum output current step (ΔI_O) = 34.5 A
- Maximum output thermal current (I_{OTDC}) = 32 A
- Number of phases (n) = 2
- Switching frequency per phase (f_{SW}) = 280 kHz
- Duty cycle at maximum input voltage (D_{MIN}) = 0.061
- Duty cycle at minimum input voltage (D_{MAX}) = 0.164

SETTING THE CLOCK FREQUENCY FOR PWM MODE

In PWM mode operation, The ADP3207 uses a fixed-frequency control architecture. The frequency is set by an external timing resistor (R_T). The clock frequency and the number of phases determine the switching frequency per phase, which directly relates to switching losses, and the sizes of the inductors and input and output capacitors. In a 2-phase design, a clock frequency of 560 kHz sets the switching frequency to 280 kHz per phase. This selection represents a trade-off between the switching losses and the minimum sizes of the output filter components. To achieve a 560 kHz oscillator frequency at VID voltage 1.150 V, R_T has to be 237 k Ω . Alternatively, the value for R_T can be calculated using

$$R_T = \frac{V_{VID} + 1.0 \text{ V}}{n \times f_{SW} \times 16 \text{ pF}} - 5 \text{ k}\Omega \quad (1)$$

where 16 pF and 25 k Ω are internal IC component values. For good initial accuracy and frequency stability, it is recommended to use a 1% resistor.

SOFT-START AND CURRENT-LIMIT LATCH-OFF DELAY TIMES

The soft-start and current-limit latch-off delay functions share the SS pin. Consequently, these two parameters must be considered together. The first step is to set C_{SS} for the soft-start ramp. This ramp is generated with a 8 μ A internal current source. The value for C_{SS} can be set as

$$C_{SS} = \frac{8 \mu\text{A} \times t_{SS}}{V_{BOOT}} \quad (2)$$

where:

V_{BOOT} is the boot voltage for the CPU, defined in the IMVP-6 specification as 1.2 V.

t_{SS} is the desired soft-start time, recommended to be below 3 ms in the IMVP-6 specification.

Assuming a desired soft-start time of 2 ms, C_{SS} is 13.3 nF, with the closest standard capacitance at 12 nF.

Once C_{SS} has been chosen, the current-limit latch-off time is equal to 7.2 ms according to the following calculation:

$$t_{DELAY} = \frac{1.2 \text{ V} \times C_{SS}}{2 \mu\text{A}} \quad (3)$$

PWRGD DELAY TIMER

The PWRGD delay, t_{CPU_PWRGD} , is defined in the IMVP-6 specification as the time period between the CLKEN assertion and the PWRGD assertion. It is programmed by a cap on the PGDELAY pin.

$$C_{PGDLY} = \frac{1.9 \mu\text{A} \times t_{CPU_PWRGD}}{2.9 \text{ V}} \quad (4)$$

The IMVP-6 specifies that the PWRGD delay is between 3 ms to 20 ms. Assuming 7 ms PWRGD delay is preferred, then C_{PGDLY} is 4.7 nF.

INDUCTOR SELECTION

The choice of inductance determines the ripple current in the inductor. Less inductance leads to more ripple current, which increases the output ripple voltage and conduction losses in the MOSFETs. However, this allows the use of smaller-size inductors, and for a specified peak-to-peak transient deviation, it allows less total output capacitance. Conversely, a higher inductance means lower ripple current and reduced conduction losses, but requires larger size inductors and more output capacitance for the same peak-to-peak transient deviation. In a multiphase converter, the practical peak-to-peak inductor ripple current is less than 50% of the maximum dc current in the same inductor. Equation 5 shows the relationship between the inductance, oscillator frequency, and peak-to-peak ripple current. Equation 6 can be used to determine the minimum inductance based on a given output ripple voltage.

$$I_R = \frac{V_{VID} \times (1 - D_{MIN})}{f_{SW} \times L} \quad (5)$$

$$L \geq \frac{V_{VID} \times R_O \times (1 - (n \times D_{MIN})) \times (1 - D_{MIN})}{f_{SW} \times V_{RIPPLE}} \quad (6)$$

Solving Equation 6 for a 20 mV peak-to-peak output ripple voltage yields

$$L \geq \frac{1.150 \text{ V} \times 2.1 \text{ m}\Omega \times (1 - (2 \times 0.061)) \times (1 - 0.061)}{280 \text{ kHz} \times 20 \text{ mV}} = 356 \text{ nH}$$

If the ripple voltage ends up being less than the initially selected value, then the inductor can be changed to a smaller value until the ripple value is met. This iteration allows optimal transient response and minimum output decoupling.

The smallest possible inductor should be used to minimize the number of output capacitors. For this example, choosing a 360 nH inductor is a good starting point, and gives a calculated ripple current of 10.7 A. The inductor should not saturate at the peak current of 27.4 A, and should be able to handle the sum of the power dissipation caused by the average current of 16 A in the winding and core loss.

Another important factor in the inductor design is the DCR, which is used to measure phase currents. A large DCR causes excessive power losses, though too small a value leads to increased measurement error. This example uses an inductor with a DCR of 0.89 m Ω .

Selecting a Standard Inductor

Once the inductance and DCR are known, the next step is to either design an inductor or select a standard inductor that comes as close as possible to meeting the overall design goals. It is also important to have the inductance and DCR tolerance specified to keep the accuracy of the system controlled; 20% inductance and 15% DCR (at room temperature) are reasonable assumptions that most manufacturers can meet.

Power Inductor Manufacturers

The following companies provide surface mount power inductors optimized for high power applications upon request:

- Vishay Dale Electronics, Inc.
<http://www.vishay.com>
- Panasonic
<http://www.panasonic.com>
- Sumida Corporation
<http://www.sumida.com>
- NEC Tokin Corporation
<http://www.nec-tokin.com>

Output Droop Resistance

The inductor design requires that the regulator output voltage measured at the CPU pins drops when the output current increases. The specified voltage drop corresponds to a dc output resistance (R_O).

The output current is measured by summing the currents of the resistors monitoring the voltage across each inductor and by passing the signal through a low-pass filter. This summer-filter is implemented by the CS amplifier that is configured with resistors $R_{PH(X)}$ (summer), and R_{CS} and C_{CS} (filter). The output resistance of the regulator is set by the following equations, where R_L is the DCR of the output inductors:

$$R_O = \frac{R_{CS}}{R_{PH(X)}} \times R_L \quad (7)$$

$$C_{CS} = \frac{L}{R_L \times R_{CS}} \quad (8)$$

Users have the flexibility of choosing either R_{CS} or $R_{PH(X)}$. Due to the current drive ability of the CSCOMP pin, the R_{CS} resistance should be larger than 100 k Ω . For example, users should initially select R_{CS} to be equal to 220 k Ω , then use Equation 8 to solve for C_{CS}

$$C_{CS} = \frac{360 \text{ nH}}{0.89 \text{ m}\Omega \times 220 \text{ k}\Omega} = 1.84 \text{ nF}$$

Because C_{CS} is not the standard capacitance, it is implemented with two standard capacitors in parallel: 1.8 nF and 47 pF. For the best accuracy, C_{CS} should be a 5% NPO capacitor.

Next, solve $R_{PH(X)}$ by rearranging Equation 7.

$$R_{PH(X)} \geq \frac{0.89 \text{ m}\Omega}{2.1 \text{ m}\Omega} \times 220 \text{ k}\Omega = 93.2 \text{ k}\Omega$$

The standard 1% resistor for $R_{PH(X)}$ is 93.1 k Ω .

Inductor DCR Temperature Correction

With the inductor DCR used as a sense element, and copper wire being the source of the DCR, users need to compensate for temperature changes in the inductor's winding. Fortunately, copper has a well-known temperature coefficient (TC) of 0.39%/°C.

If R_{CS} is designed to have an opposite sign but equal percentage change in resistance, then it cancels the temperature variation of the inductor DCR. Due to the nonlinear nature of NTC thermistors, series resistors, R_{CS1} and R_{CS2} (see Figure 11) are needed to linearize the NTC and produce the desired temperature coefficient tracking.

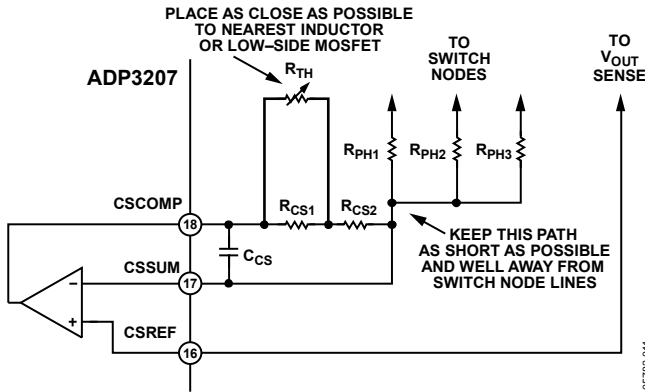

Figure 11. Temperature Compensation Circuit Values

The following procedure and equations yield values for R_{CS1} , R_{CS2} , and R_{TH} (the thermistor value at 25°C) for a given R_{CS} value:

1. Select an NTC to be used based on type and value. Because there is no value yet, start with a thermistor with a value close to R_{CS} . The NTC should also have an initial tolerance of better than 5%.
2. Based on the type of NTC, find its relative resistance value at two temperatures. Temperatures that work well are 50°C and 90°C. These are called Resistance Value A ($A = R_{TH}(50°C)/R_{TH}(25°C)$) and Resistance Value B ($B = R_{TH}(90°C)/R_{TH}(25°C)$). Note that the relative value of NTC is always 1 at 25°C.
3. Next, find the relative value of R_{CS} that is required for each of these temperatures. This is based on the percentage of change needed, which is initially 0.39%/°C. These are called r_1 and r_2 .

$$r_1 = \frac{1}{1 + TC \times (T_1 - 25)} \quad (9)$$

$$r_2 = \frac{1}{1 + TC \times (T_2 - 25)}$$

where:

$$TC = 0.0039$$

$$T_1 = 50°C$$

$$T_2 = 90°C.$$

4. Compute the relative values for r_{CS1} , r_{CS2} , and r_{TH} using

$$r_{CS2} = \frac{(A - B) \times r_1 \times r_2 - A \times (1 - B) \times r_2 + B \times (1 - A) \times r_1}{A \times (1 - B) \times r_1 - B \times (1 - A) \times r_2 - (A - B)}$$

$$r_{CS1} = \frac{(1 - A)}{1 - r_{CS2} - \frac{A}{r_1 - r_{CS2}}}$$

$$r_{TH} = \frac{1}{1 - r_{CS2} - \frac{1}{r_{CS1}}}$$

5. Calculate $R_{TH} = R_{TH} \times R_{CS}$, then select the closest value of thermistor that is available. Also, compute a scaling factor k based on the ratio of the actual thermistor value relative to the computed one

$$k = \frac{R_{TH(ACTUAL)}}{R_{TH(CALCULATED)}} \quad (11)$$

6. Finally, calculate values for R_{CS1} and R_{CS2} using

$$R_{CS1} = R_{CS} \times k \times r_{CS1}$$

$$R_{CS2} = R_{CS} \times ((1 - k) + (k \times r_{CS2})) \quad (12)$$

This example starts with a thermistor value of 100 kΩ and uses a Vishay NTHS0603N04 NTC thermistor (a 0603 size thermistor) with $A = 0.3359$ and $B = 0.0771$. From this data, $r_{CS1} = 0.359$, $r_{CS2} = 0.729$ and $r_{TH} = 1.094$. Solving for R_{TH} yields 240 kΩ, so 220 kΩ is chosen, making $k = 0.914$. Finally, R_{CS1} and R_{CS2} are 72.3 kΩ and 166 kΩ. Choosing the closest 1% resistor values yields a choice of 71.5 kΩ and 165 kΩ.

C_{OUT} SELECTION

The required output decoupling for processors and platforms is typically recommended by Intel. The following guidelines can also be used if both bulk and ceramic capacitors in the system:

- Select the total amount of ceramic capacitance. This is based on the number and type of capacitors to be used. The best location for ceramics is inside the socket; 20 pieces of Size 0805 being the physical limit. Additional capacitors can be placed along the outer edge of the socket.
- Select the number of ceramics and find the total ceramic capacitance (C_z). Combined ceramic values of 200 μF to 300 μF are recommended and are usually made up of multiple 10 μF or 22 μF capacitors.
- Note that there is an upper limit imposed on the total amount of bulk capacitance (C_x) when considering the VID on-the-fly output voltage stepping (voltage step V_V in time t_V with error of V_{ERR}), and also a lower limit based on meeting the critical capacitance for load release at a given maximum load step ΔI_O . For a step-off load current, the current version of the IMVP-6 specification allows a maximum V_{CORE} overshoot (V_{OSMAX}) of 10 mV, plus 1.5% of the VID voltage. For example, if the VID is 1.150 V, then the largest overshoot allowed is 27 mV.

$$C_{x(MIN)} \geq \frac{L \times \Delta I_O}{n \times R_O + \frac{V_{OSMAX}}{\Delta I_O} \times V_{VID}} - C_z \quad (13)$$

$$C_{x(MAX)} \leq \frac{L}{nK^2 R_O^2} \times \frac{V_V}{V_{VID}} \times \sqrt{1 + t_V \frac{V_{VID}}{V_V} \times \frac{nKR_O^2}{L}} - 1 - C_z \quad (14)$$

where:

$$K = -1n \frac{V_{ERR}}{V_V} \quad (15)$$

To meet the conditions of these equations and transient response, the ESR of the bulk capacitor bank (R_X) should be less than two times the droop resistance, R_O . If the $C_{X(MIN)}$ is larger than $C_{X(MAX)}$, the system does not meet the VID on-the-fly and/or deeper sleep exit specification and can require a smaller inductor or more phases (the switching freq

where:

n_{MF} is the total number of main MOSFETs.

R_G is the total gate resistance (1.5 Ω for the ADP3419 and about 0.5 Ω for two pieces of typical high speed switching MOSFETs, making $R_G = 2 \Omega$).

C_{ISS} is the input capacitance of the main MOSFET. The best thing to reduce switching loss is to use lower gate capacitance devices.

The conduction loss of the main MOSFET is given by

$$P_{C(MF)} = D \times \frac{I_O^2}{n_{MF}} + \frac{1}{12} \times \frac{n \times I_R^2}{n_{MF}} \times R_{DS(MF)} \quad (19)$$

where:

$R_{DS(MF)}$ is the on-resistance of the MOSFET.

Typically, for main MOSFETs, users want the highest speed (low C_{ISS}) device, but these usually have higher on-resistance. Users must select a device that meets the total power dissipation (0.6 W for a single 8-lead SOIC package) when combining the switching and conduction losses.

For example, using an IRF7821 device as the main MOSFET (four in total; that is, $n_{MF} = 4$), with about $C_{ISS} = 1010$ pF (max) and $R_{DS(MF)} = 18$ m Ω (max at $T_J = 120^\circ\text{C}$) and an IR7832 device as the synchronous MOSFET (four in total; that is, $n_{SF} = 4$), $R_{DS(SF)} = 6.7$ m Ω (max at $T_J = 120^\circ\text{C}$). Solving for the power dissipation per MOSFET at $I_O = 32$ A and $I_R = 10.7$ A yields 420 mW for each synchronous MOSFET and 410 mW for each main MOSFET.

One last consideration is the power dissipation in the driver for each phase. This is best described in terms of the QG for the MOSFETs and is given by the following equation:

$$P_{DRV} = \frac{f_{SW}}{2 \times n} \times (n_{MF} \times Q_{GMF} + n_{SF} \times Q_{GSF}) + I_{CC} \times V_{CC} \quad (20)$$

where:

Q_{GMF} is the total gate charge for each main MOSFET.

Q_{GSF} is the total gate charge for each synchronous MOSFET.

Also shown is the standby dissipation ($I_{CC} \times V_{CC}$) of the driver. For the ADP3419, the maximum dissipation should be less than 300 mW, considering its thermal impedance is 220 $^\circ\text{C}/\text{W}$ and the maximum temperature increase is 50 $^\circ\text{C}$. For this example, with $I_{CC} = 2$ mA, $Q_{GMF} = 14$ nC and $Q_{GSF} = 51$ nC, there is 120 mW dissipation in each driver, which is below the 300 mW dissipation limit. See the ADP3419 data sheet for more details.

RAMP RESISTOR SELECTION

The ramp resistor (R_R) is used for setting the size of the internal PWM ramp. The value of this resistor is chosen to provide the best combination of thermal balance, stability, and transient response. Use this equation to determine a starting value

$$R_R = \frac{A_R \times L}{3 \times A_D \times R_{DS} \times C_R} \quad (21)$$

$$R_R = \frac{0.2 \times 360 \text{ nH}}{3 \times 5 \times 3.4 \text{ m}\Omega \times 5 \text{ pF}} = 282 \text{ k}\Omega$$

where:

A_R is the internal ramp amplifier gain.

A_D is the current balancing amplifier gain.

R_{DS} is the total low-side MOSFET ON-resistance,

C_R is the internal ramp capacitor value.

Another consideration in the selection of R_R is the size of the internal ramp voltage (see Equation 22). For stability and noise immunity, keep this ramp size larger than 0.5 V. Taking this into consideration, the value of R_R is selected as 280 k Ω .

The internal ramp voltage magnitude can be calculated using:

$$V_R = \frac{A_R \times (1 - D) \times V_{VID}}{R_R \times C_R \times f_{SW}} \quad (22)$$

$$V_R = \frac{0.2 \times (1 - 0.061) \times 1.150 \text{ V}}{280 \text{ k}\Omega \times 5 \text{ pF} \times 280 \text{ kHz}} = 0.55 \text{ V}$$

The size of the internal ramp can be made larger or smaller. If it is made larger, then stability and transient response improves, but thermal balance degrades. Likewise, if the ramp is made smaller, then thermal balance improves at the sacrifice of transient response and stability. The factor of three in the denominator of Equation 21 sets a minimum ramp size that gives an optimal balance for good stability, transient response, and thermal balance.

COMP Pin Ramp

There is a ramp signal on the COMP pin due to the droop voltage and output voltage ramps. This ramp amplitude adds to the internal ramp to produce the following overall ramp signal at the PWM input:

$$V_{RT} = \frac{V_R}{1 - \frac{2 \times (1 - n \times D)}{n \times f_{SW} \times C_X \times R_O}} \quad (23)$$

For this example, the overall ramp signal is found to be 1.5 V.

SETTING THE SWITCHING FREQUENCY FOR RPM MODE OPERATION OF PHASE 1

During the RPM mode operation of Phase 1, the ADP3207 runs in pseudo constant frequency, given that the load current is high enough for continuous current mode. While in discontinuous current mode, the switching frequency is reduced with the load current in a linear manner. When considering power conversion efficiency in light load, lower switching frequency is usually preferred for RPM mode. However, the V_{CORE} ripple specification in the IMVP-6 sets the limitation for lowest switching frequency. Therefore, depending on the inductor and output capacitors, the switching frequency in RPM mode can be equal, larger, or smaller than its counterpart in PWM mode.

A resistor between VRPM and RRPm pins sets the pseudo constant frequency as following:

$$R_{RPM} = \frac{2 \times R_T}{V_{VID} + 1.0 \text{ V}} \times \frac{A_R \times (1 - D) \times V_{VID}}{R_R \times C_R \times f_{SW}} - 0.5 \text{ k}\Omega \quad (24)$$

where:

A_R is the internal ramp amplifier gain.

C_R is the internal ramp capacitor value.

R_R is an external resistor on the RAMPADJ pin to set the internal ramp magnitude.

Because $R_R = 280 \text{ k}\Omega$, the following resistance sets up 300 kHz switching frequency in RPM operation.

$$R_{RPM} = \frac{2 \times 237 \text{ k}\Omega}{1.150 \text{ V} + 1.0 \text{ V}} \times \frac{0.2 \times (1 - 0.061) \times 1.150}{280 \text{ k}\Omega \times 7 \text{ pF} \times 300 \text{ kHz}} - 500 \Omega = 80.6 \text{ k}\Omega$$

CURRENT-LIMIT SETPOINT

To select the current-limit setpoint, we need to find the resistor value for R_{LIM} . The current-limit threshold for the ADP3207 is set with a 1.7 V source (V_{LIM}) across R_{LIM} with a gain of 13 mV/ μ A. R_{LIM} can be found using the following equation:

$$R_{LIM} = \frac{A_{LIM} \times V_{LIM}}{I_{LIM} \times R_O} \quad (25)$$

For values of R_{LIM} greater than 500 k Ω , the current limit may be lower than expected, so some adjustment of R_{LIM} may be needed. Here, I_{LIM} is the average current limit for the output of the supply. In this example, if choosing 55 A for I_{LIM} , R_{LIM} is 190 k Ω , which is close to a standard 1% resistance of 191 k Ω .

The per-phase current limit described earlier has its limit determined by the following:

$$I_{PHLIM} \cong \frac{V_{COMP(MAX)} - V_R - V_{BIAS}}{A_D \times R_{DS(MAX)}} + \frac{I_R}{2} \quad (26)$$

For the ADP3207, the maximum COMP voltage ($V_{COMP(MAX)}$) is 3.3 V, the COMP pin bias voltage (V_{BIAS}) is 1.0 V, and the current balancing amplifier gain (A_D) is 5. Using a V_R of 0.55 V, and a $R_{DS(MAX)}$ of 3.8 m Ω (low-side on-resistance at 150°C) results in a per-phase limit of 85 A. Although this number seems high, this current level can only be reached with an absolute short at the output and the current-limit latch-off function shutting down the regulator before overheating occurs.

This limit can be adjusted by changing the ramp voltage V_R . However, users should not set the per-phase limit lower than the average per-phase current (I_{LIM}/n).

There is also a per-phase initial duty-cycle limit at maximum input voltage:

$$D_{LIM} = D_{MIN} \times \frac{V_{COMP(MAX)} - V_{BIAS}}{V_R} \quad (27)$$

For this example, the duty-cycle limit at maximum input voltage is found to be 0.25 when D is 0.061.

FEEDBACK LOOP COMPENSATION DESIGN

Optimized compensation of the ADP3207 allows the best possible response of the regulator's output to a load change. The basis for determining the optimum compensation is to make the regulator and output decoupling appear as an output impedance that is entirely resistive over the widest possible frequency range, including dc, and equal to the droop resistance (R_O). With the resistive output impedance, the output voltage droops in proportion with the load current at any load current slew rate. This ensures the optimal positioning and minimizes the output decoupling.

With the multimode feedback structure of the ADP3207, users need to set the feedback compensation to make the converter output impedance work in parallel with the output decoupling. Several poles and zeros are created by the output inductor and decoupling capacitors (output filter) that need to be compensated for.

A type-three compensator on the voltage feedback is adequate for proper compensation of the output filter. Equation 28 to Equation 36 is intended to yield an optimal starting point for the design; some adjustments can be necessary to account for PCB and component parasitic effects (see the Tuning Procedure for ADP3207).

ADP3207

The first step is to compute the time constants for all of the poles and zeros in the system

$$R_E = n \times R_O + A_D \times R_{DS} + \frac{R_L \times V_{RT}}{V_{ID}} + \frac{2 \times L \times (1 - n \times D) \times V_{RT}}{n \times C_X \times R_O \times V_{VID}} \quad (28)$$

$$T_A = C_X \times (R_O - R') + \frac{L_X}{R_O} \times \frac{R_O - R'}{R_X} \quad (29)$$

$$T_B = (R_X + R' - R_O) \times C_X \quad (30)$$

$$T_C = \frac{V_{RT} \times L - \frac{A_D \times R_{DS}}{2 \times f_{SW}}}{V_{VID} \times R_E} \quad (31)$$

$$T_D = \frac{C_X \times C_Z \times R_O^2}{C_X \times (R_O - R') + C_Z \times R_O} \quad (32)$$

where:

R' is the PCB resistance from the bulk capacitors to the ceramics.

R_{DS} is the total low-side MOSFET on-resistance per phase.

For this example, A_D is 5, $V_{RT} = 1.5$ V, R' is approximately 0.4 m Ω (assuming an 8-layer motherboard) and L_X is 250 pH for the four Panasonic SP capacitors.

The compensation values can be solved using the following:

$$C_A = \frac{n \times R_O \times T_A}{R_E \times R_B} \quad (33)$$

$$R_A = \frac{T_C}{C_A} \quad (34)$$

$$C_B = \frac{T_B}{R_B} \quad (35)$$

$$C_{FB} = \frac{T_D}{R_A} \quad (36)$$

The standard values for these components are subject to the tuning procedure, as introduced in the CIN Selection and Input Current DI/DT Reduction section.

CIN SELECTION AND INPUT CURRENT DI/DT REDUCTION

In continuous inductor-current mode, the source current of the high-side MOSFET is approximately a square wave with a duty ratio equal to $n \times V_{OUT}/V_{IN}$ and an amplitude of 1-nth the maximum output current. To prevent large voltage transients, a low ESR input capacitor sized for the maximum rms current must be used. The maximum rms capacitor current happens at the lowest input voltage, and is given by:

$$I_{CRMS} = D \times I_O \times \sqrt{\frac{1}{n \times D} - 1} \quad (37)$$

$$I_{CRMS} = 0.164 \times 44 \text{ A} \times \sqrt{\frac{1}{2 \times 0.164} - 1} = 10.3 \text{ A}$$

In a typical notebook system, the battery rail decouplings are MLCC capacitors or a mixture of MLCC capacitors and bulk capacitors. In this example, the input capacitor bank is formed by eight pieces of 10 μ F, and 25 V MLCC capacitors with a ripple current rating of about 1.5 A each.

SOFT TRANSIENT SETTING

As described in the Soft Transient section, during the soft transient, the slew rate of V_{CORE} reference voltage change is controlled by the STSET pin capacitance. Because the timing of deeper sleep exit is critical, the STSET pin capacitance is set to satisfy the fast deeper sleep exit slew rate as

$$C_{STSET} = \frac{8 \mu \text{ A}}{2 \times SLEWRATE_{CAE}} \quad (38)$$

where:

8 μ A is the source/sink current of the STSET pin.

$SLEWRATE_{CAE}$ is the voltage slew rate during deeper sleep exit, defined as 10 mV/ μ s in the IMVP-6 specification.

C_{STSET} equals 400 pF, with the closest standard capacitance at 390 pF.

SELECTING THERMAL MONITOR COMPONENTS

For single-point hot spot thermal monitoring, simply set R_{TTSET1} equal to the NTC thermistor's resistance at the alarm temperature (see Figure 12). For example, if the V_{RTT} alarm temperature is 100°C using a Vishay thermistor (NTHS-0603N011003J) with a resistance of 100 k Ω at 25°C, and 6.8 k Ω at 100°C, simply set $R_{TTSET1} = R_{TH1}(100^\circ\text{C})$ to 6.8 k Ω .

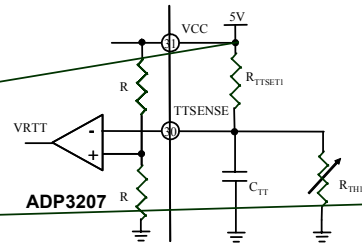

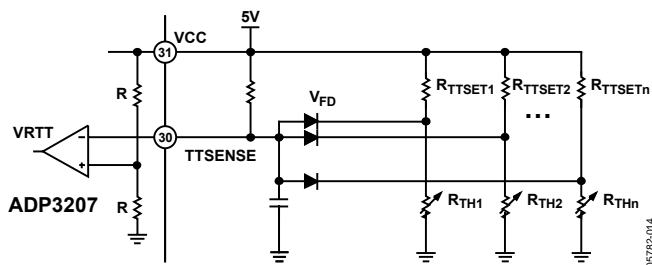

Figure 13. Multiple-Point Thermal Monitoring

The number of hot spots monitored is not limited. The alarm temperature of each hot spot can be set differently by playing different R_{TTSET1} , R_{TTSET2} , R_{TTSETn} .

TUNING PROCEDURE FOR ADP3207

1. Build the circuit based on compensation values computed from Equation 1 to Equation 39.
2. Hook-up the dc load to the circuit. Turn the circuit on and verify operation. Check for jitter at no load and full load.

DC Loadline Setting

3. Measure the output voltage at no load (V_{NL}). Verify that it is within tolerance.
4. Measure the output voltage at full load and at cold (V_{FLCOLD}). Let the board set for a ~10 minutes at full load and measure the output (V_{FLHOT}). If there is a change of more than a few millivolts, then adjust R_{CS1} and R_{CS2} using Equation 40 and Equation 41.

$$R_{CS2(NEW)} = R_{CS2(OLD)} \times \frac{V_{NL} - V_{FLCOLD}}{V_{NL} - V_{FLHOT}} \quad (40)$$

5. Repeat Step 4 until cold and hot voltage measurements remain the same.
6. Measure output voltage from no load to full load using 5 A steps. Compute the load line slope for each change and then average it to get the overall load line slope (R_{OMEAS}).
7. If R_{OMEAS} is off from R_O by more than 0.05 m Ω , use the following to adjust the R_{PH} values:

$$R_{PH(NEW)} = R_{PH(OLD)} \times \frac{R_{OMEAS}}{R_O} \quad (41)$$

8. Repeat Step 6 and Step 7 to check load line and repeat adjustments if necessary.
9. Once complete with dc load line adjustment, do not change R_{PH} , R_{CS1} , R_{CS2} , or R_{TH} for the rest of procedure.
10. Measure output ripple at no load and full load with a scope to make sure it is within specification.

AC Loadline Setting

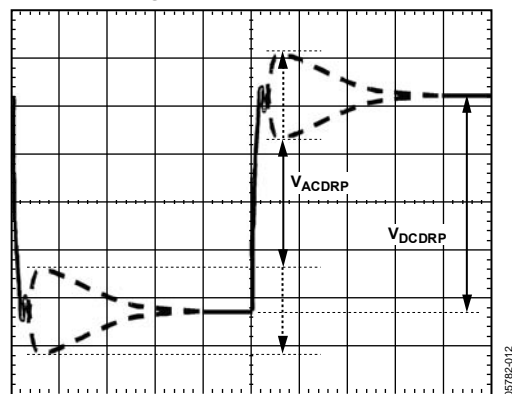

Figure 14. AC Loadline Waveform

11. Remove the dc load from the circuit and hook up the dynamic load.
12. Hook up the scope to the output voltage and set it to dc coupling with the time scale at 100 μ s/div.
13. Set the dynamic load for a transient step of about 40 A at 1 kHz with a 50% duty cycle.
14. Measure the output waveform (using the dc offset on scope to see the waveform, if necessary). Try to use the vertical scale of 100 mV/div or finer.
15. Users should see a waveform that similar to the one in Figure 15. Use the horizontal cursors to measure V_{ACDRP} and V_{DCDRP} as shown. Do not measure the undershoot or overshoot that occurs immediately after the step.
16. If the V_{ACDRP} and V_{DCDRP} are different by more than a couple of mV, use the following to adjust C_{CS} (note that users may need to parallel different values to get the right one due to the limited standard capacitor values available. It is also wise to have locations for two capacitors in the layout for this):

$$C_{CS(NEW)} = C_{CS(OLD)} \times \frac{V_{ACDRP}}{V_{DCDRP}} \quad (42)$$

17. Repeat Steps 15 and Step 16. Repeat adjustments if necessary. Once complete, do not change C_{CS} for the rest of the procedure.
18. Set dynamic load step to maximum step size. Do not use a step size larger than needed. Verify that the output waveform is square, which means V_{ACDRP} and V_{DCDRP} are equal.

Note: Make sure that the load step slew rate and turn-on are set for a slew rate of ~150 A/ μ s to 250 A/ μ s (for example, a load step of 50 A should take 200 ns to 300 ns) with no overshoot. Some dynamic loads have an excessive turn-on overshoot if a minimum current is not set properly (this is an issue if you are using a VTT tool).

Initial Transient Setting

19. With dynamic load still set at the maximum step size, expand the scope time scale to see 2 $\mu\text{s}/\text{div}$ to 5 $\mu\text{s}/\text{div}$. A waveform that has two overshoots and one minor undershoot can result (see Figure 15). Here, VDROOP is the final desired value.

Power Circuitry

Avoid crossing any signal lines over the switching power path loop. This path should be routed on the PCB to encompass the shortest possible length in order to minimize radiated switching noise energy (that is, EMI) and conduction losses in the board. Failure to take proper precautions often results in EMI problems for the entire PC system as well as noise-related operational problems in the power converter control circuitry. The switching power path is the loop formed by the current path through the input capacitors and the power MOSFETs, including all interconnecting PCB traces and planes. The use of short and wide interconnection traces is especially critical in this path for two reasons: it minimizes the inductance in the switching loop, which can cause high energy ringing, and it accommodates the high current demand with minimal voltage loss.

Whenever a power-dissipating component (for example, a power MOSFET) is soldered to a PCB, the liberal use of vias, both directly on the mounting pad and immediately surrounding it, is recommended. Two important reasons for this are: improved current rating through the vias, and improved thermal performance from vias extended to the opposite side of the PCB where a plane can more readily transfer the heat to the air. Make a mirror image of any pad being used to heat sink the MOSFETs on the opposite side of the PCB to achieve the best thermal dissipation to the air around the board. To further improve thermal performance, the largest possible pad area should be used.

The output power path should also be routed to encompass a short distance. The output power path is formed by the current path through the inductor, the output capacitors, and the load.

For best EMI containment, use a solid power ground plane as one of the inner layers extending fully under all the power components.

It is important for conversion efficiency that MOSFET drivers, such as ADP3419, are placed as close to the MOSFETs as possible. Thick and short traces are required between the driver and MOSFET gate, especially for the SR MOSFETs. Ground the MOSFET driver's GND pin through immediately close vias.

Signal Circuitry

The output voltage is sensed and regulated between the FB pin and the FBRTN pin, which connects to the signal ground at the load. To avoid differential mode noise pickup in the sensed signal, the loop area should be small. Thus, route the FB and FBRTN traces adjacent to each other atop the power ground plane back to the controller. To filter any noise from the FBRTN trace, using a 1000 pF MLCC is suggested. It should be placed between the FBRTN pin and local ground and as close to the FBRTN pin as possible.

Connect the feedback traces from the switch nodes as close as possible to the inductor. The CSREF signal should be Kelvin connected to the center point of the copper bar, which is the V_{CORE} common node for the inductors of all phases.

In the back side of the ADP3207 package, a metal pad can be used as the device heat sink. In addition, running vias under the ADP3207 is not recommended because the metal pad can cause shorting between vias.

ADP3207

OUTLINE DIMENSIONS

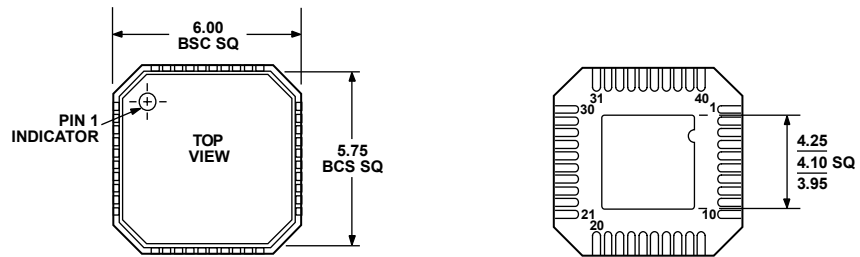

NOTES

ADP3207

NOTES