

LDM30

General Purpose Limited Distance Modem

Description

The LDM30 series of products is designed to allow video display terminals (VDTs) and other RS-232 devices to be connected over distances sufficient to cover any industrial or institutional complex of buildings. These modems feature a rugged aluminum enclosure small enough to mount on the back panel of VDT units, saving valuable desk and floor space.

The LDM30 series is designed for full-duplex, asynchronous operation over two, DC-continuity, non-loaded, twisted-wire pairs. Through special high-speed optically-coupled circuits they may communicate at data rates up to 57,600 baud. A self-powered model and a host-powered model are available. The self-powered unit uses 12VAC from a wall-mounted transformer while the host-powered unit takes \pm DC power from pins 9 and 10 of the RS-232 connector. The modem circuits — and, consequently, the host device — are protected from electrical transients due to lightning strikes or operation of heavy industrial equipment.

Each device features a convenient Data-Communication Equipment (DCE) to Data-Terminal Equipment (DTE) switch which reverses pins 2 and 3 of the RS-232 connector. For installation and troubleshooting, each unit has diagnostic Light-Emitting Diodes (LEDs) on the transmit and receive lines.

The RS-232 connector may be ordered as a male or female 25-pin connector. Field connection is made through a modern, solderless, screw-termination assembly. Alternatively, a convenient four-wire modular phone jack (RJ-11) is available.

Specifications

Model	LDM30
Baud Rate Range	0 – 57.6K
Baud Rate	57.6K 38.4K 19.2K 9.6K 4.8K 2.4K 1.2K – 0
Distance (miles)	0.5 0.75 1.0 3 5 7 12
Distance (km)	0.8 1.25 1.7 5 8.3 11.7 20
Common Mode Isolation	500V Surge, 300V Continuous
Differential Mode Surge Protection (3 devices)	ANSI/IEEE C37.90.1-1989
Channel Lines ⁽¹⁾	TD, RD
Control Lines ⁽¹⁾	RTS, CTS, DTR, DSR, RLSD
Modes	Asynchronous 4-wire full duplex, 2-wire simplex

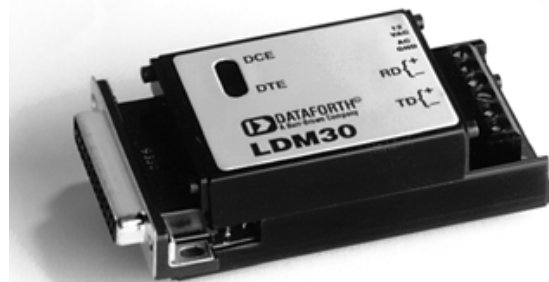

Features

- DC TO 57,600 BAUD
- OPTICAL ISOLATION
- SURGE PROTECTORS
- LED DIAGNOSTIC INDICATORS
- OPERATION TO 3 MILES (5KM) AT 9600 BAUD, 1 MILE (1.7KM) AT 19,200, 0.5 MILES (0.8KM) AT 57,600
- FOUR-WIRE FULL DUPLEX, TWO-WIRE SIMPLEX
- SELF-POWERED OR HOST-POWERED
- SELECTION OF CONNECTORS
- WIDE OPERATING TEMPERATURE RANGE, 0 TO +70°C

Dataforth does not authorize or warrant its products for use in life support/critical applications.

Model	LDM30
Power: AC operation ⁽²⁾ DC operation	12VAC at 92mA \pm 9VDC to \pm 15VDC, 35mA
Temperature Operating Storage Relative Humidity	0°C to +70°C -10°C to +85°C 0-95%, non-condensing
Dimensions	3.6 in x 2.1 in x 1 in (91.4 mm x 53.3 mm x 25.4 mm)
Weight PT3 and PT3E	3.5 oz (100g) max 11.0 oz (311.8g) max
MTBF ⁽³⁾	>150,000 hrs

Notes: (1) TD = Transmit Data, RD = Receive Data, RTS = Request To Send, CTS = Clear To Send. DTR = Data Terminal Ready, DSR = Data Set Ready, RLSD = Received Line Signal Detect. (2) 120VAC and 220VAC power transformers are available. (3) Ground-benign environmental conditions (no salt atmosphere, <50°C ambient temperature).

Figure 1. LDM30 Logic Diagram

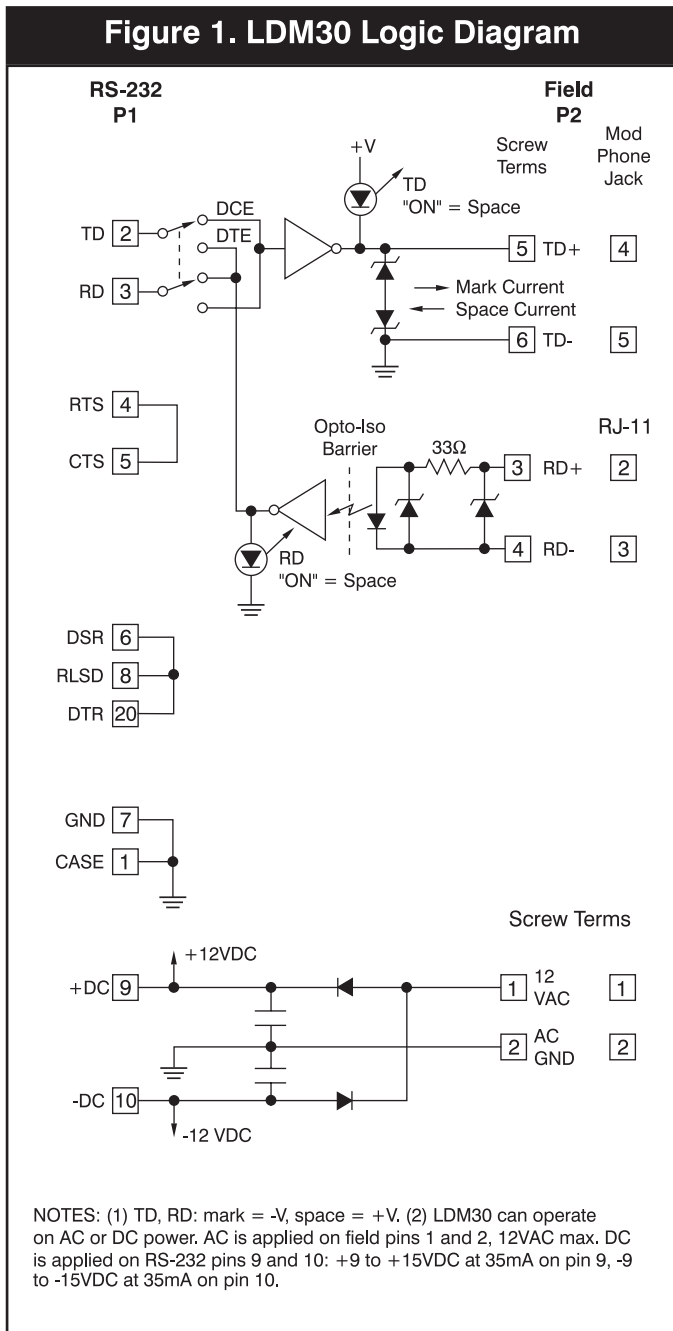

Interface

LDM30 conforms to EIA RS-232 and CCITT V.24 specifications. Pins 4 and 5 are internally connected, as are pins 6, 8, and 20; pin 7 is signal ground. Pins 2 and 3 are switch-reversible. The LDM30 logic diagram is shown in Figure 1.

Cable Capacitance Effects On Distances

Specified distances are for the wire sizes 18-24AWG (0.82-0.20mm²) with a maximum capacitance of 25pF/ft (82pF/m). For higher capacitance cables, decrease distance specifications for 2400 baud and above by a proportionate amount. For example, shielded cable with 50pF/ft (164pF/m) would reduce the distances by 50%. For host-powered units with voltages less than 11.5 VDC, distances for 1200 baud and below are reduced proportionately. Recommended wire gauges are #18 to #24 (0.82-0.20mm²).

For baud rates of 1200 and below, distances are limited by DC voltage drop. For 2400 baud and above, distances are limited by pulse distortion. The use of low-capacitance cable can extend the distances shown. Belden 9182 and 9184 are, respectively, single and dual twisted-pair cables that are especially designed for high-speed data communications applications. With these cables the distances can be extended by 50%. However, the DC-resistance-limited distance given under 1200 baud may not be exceeded.

Cable capacitance for individually shielded wire pairs is usually given by manufacturers as capacitance between wires and capacitance from each wire to the shield. The effective transmission line capacitance is approximately the interwire capacitance plus one-half of the wire-to-shield capacitance.

WARNING! If AC power is used, pins 9 and 10 of the RS-232 connector will have +12VDC and -12VDC present, respectively. These voltages can potentially damage customer equipment if the customer equipment has any signal connected to these pins. If there is doubt about signals on pins 9 and 10 of customer equipment, an interface cable should be used which has no connection to these pins.

RS-232 P1 Pin Descriptions			Field P2 Pin Descriptions		
Pin 1	CASE	Case Ground	Screw Terms		
Pin 2	TD	[3] Transmit Data	Pin 1	12VAC	Screw Terms
Pin 3	RD	[2] Receive Data	Pin 2	AC GND	
Pin 4	RTS	[7] Request To Send	Pin 3	RD+	RJ-11
Pin 5	CTS	[8] Clear To Send	Pin 4	RD-	
Pin 6	DSR	[6] Data Set Ready	Pin 5	TD+	RJ-11
Pin 7	GND	[5] Signal Ground	Pin 6	TD-	
Pin 8	RLSD	[1] Receive Line Signal Detect	Modular Phone Jack Option		
Pin 9	+DC	Positive DC Supply Input	Pin 1	12VAC	Screw Terms
Pin 10	-DC	Negative DC Supply Input	Pin 2	ACGND	
Pin 20	DTR	[4] Data Terminal Ready	Pin 3	RD+	RJ-11
			Pin 4	RD-	
			Pin 5	TD+	RJ-11
			Pin 6	TD-	

Pin numbers given are for the 25-pin connector with the 9-pin equivalent in [].

Installation

Installation of the LDM30 consists of attaching it to its mating 25-pin connector on the terminal or host computer.

In some cases an RS-232 cable will be used to connect to the RS-232, 25-pin connector of the LDM30. Mounting screws are provided for the male connector, and the female connector has threaded standoffs for connection to cables.

The DCE/DTE switch must be set to be complementary to the terminal or computer port (DCE connects to DTE and DTE to DCE). For example, a terminal connector will most likely be DTE-wired; thus LDM30 must be set to DCE to work with the DTE-wired connector. Since the LDM30 is a data-communications device, its normal switch setting will be DCE. The DTE position is provided as a convenience when it must be connected to DCE equipment, such as some computer ports or other modems.

In the event that the wiring of the host port is not known, the LED indicators will indicate the proper setting. The LED indicators come on during the occurrence of "SPACE" conditions on the transmit and receive lines. The "MARK" condition is the standby condition when the DCE/DTE switch is properly set on both ends of the correctly wired communications cable. Cable connections are shown in Figure 2. The LEDs will most often be off, coming on momentarily during the passage of a burst of data.

If the correct setting of the DCE/DTE switch is not known, change the setting to the position that causes the transmit (TD) LED to come on as described above. The repeat key on some terminals is convenient for sending continuous data, causing the TD LED to come on.

A self-test of the LDM30 may be accomplished by connecting TD+ to RD+ and TD- to RD- on the same unit. Then a terminal or computer may transmit data to itself as a test. Both the TD and RD LEDs should be off when data is not being transmitted and come on during data transmission.

Figure 2. LDM30 Field Connections

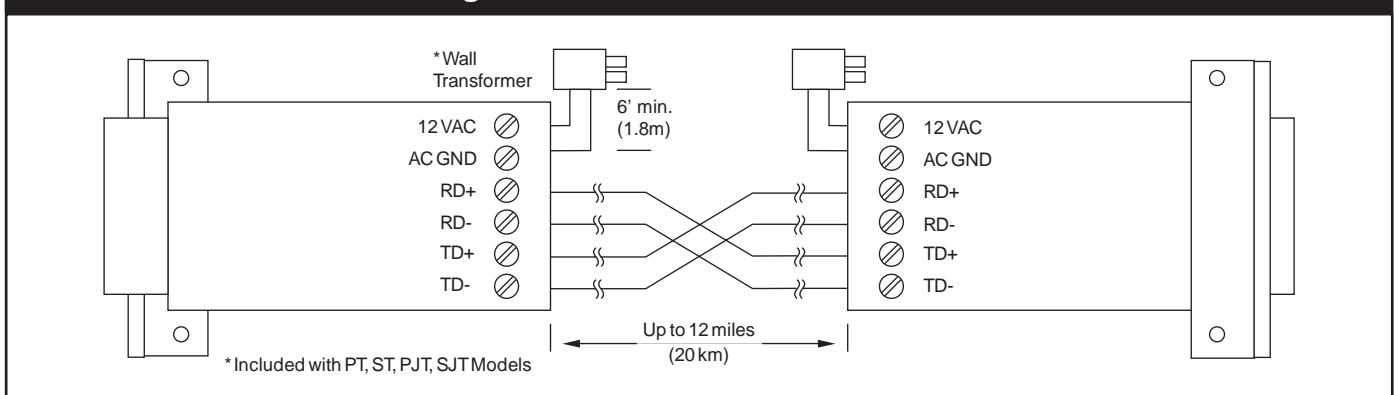
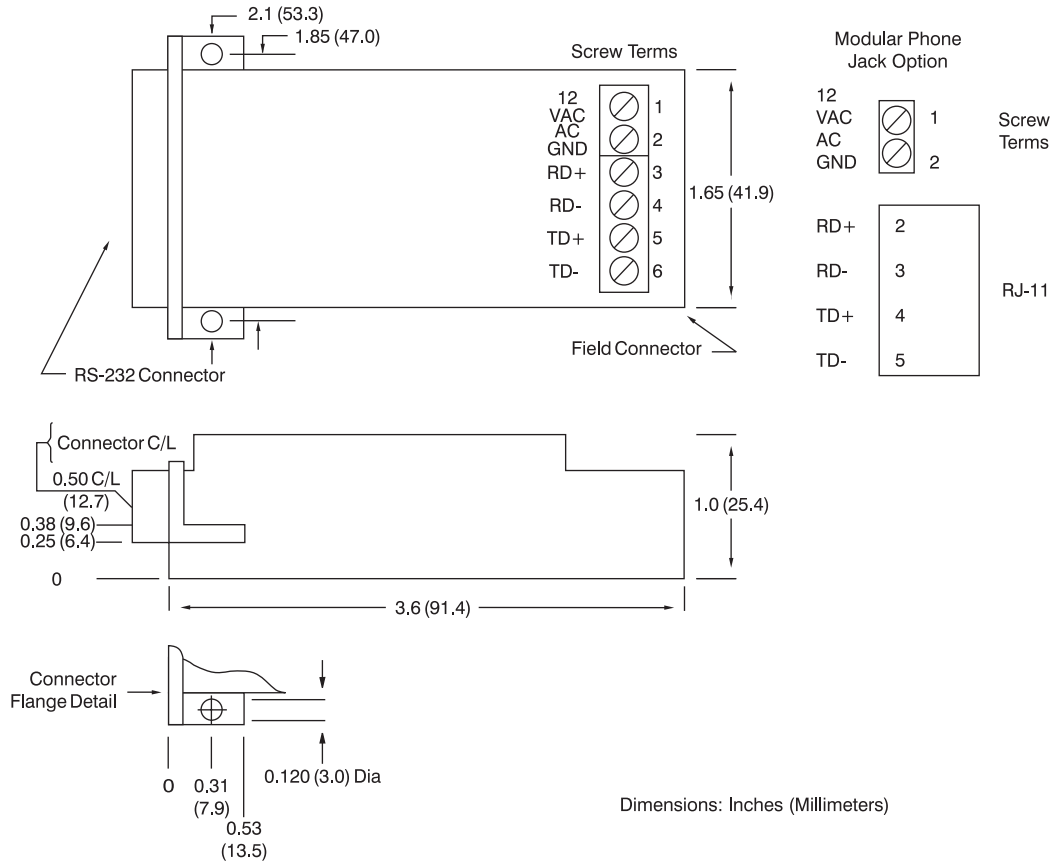

Figure 3. LDM30 Mechanical Drawing



Ordering Information

LDM30-P	Male	Host-powered	Screw termination	LDM30-PE	Male	European transformer	Screw termination
LDM30-S	Female	Host-powered	Screw termination	LDM30-SE	Female	European transformer	Screw termination
LDM30-PJ	Male	Host-powered	RJ-11 phone jack	LDM30-PJE	Male	European transformer	RJ-11 phone jack
LDM30-SJ	Female	Host-powered	RJ-11 phone jack	LDM30-SJE	Female	European transformer	RJ-11 phone jack
LDM30-PT	Male	U.S. transformer	Screw termination	PT3		U.S. style wall mount transformer, 120VAC	
LDM30-ST	Female	U.S. transformer	Screw termination	PT3E		Euro style wall mount transformer, 220VAC	
LDM30-PJT	Male	U.S. transformer	RJ-11 phone jack				
LDM30-SJT	Female	U.S. transformer	RJ-11 phone jack				