

## DATA SHEET

Form 953-030801

### Description

The SNAP-PS24 and SNAP-PS24U power supplies are designed to provide 24 volts of DC loop power for SNAP analog modules mounted on a SNAP B-Series mounting rack. The power supply is compatible with SNAP Ultimate and SNAP Ethernet I/O. These power supplies can be mounted next to a SNAP B-Series rack and brain board assembly using the standard panel-mounting base or may be mounted using the optional DIN-rail adapter (SNAP-PSDIN or SNAP-PSUDIN).

The SNAP-PS24's AC power connections are made to a removable terminal strip on top of the power supply. The DC output power is ready to be hooked up using the attached wiring harness.

Part Number	Description
SNAP-PS24	SNAP Power Supply - 24 V, 3/4 Amp
SNAP-PS24U	SNAP Power Supply - 24 V, 1-1/4 Amp
SNAP-PSDIN	DIN-Rail Adapter for SNAP-PS24
SNAP-PSUDIN	DIN-Rail Adapter for SNAP-PS24U

### SNAP-PS24 - PANEL MOUNT

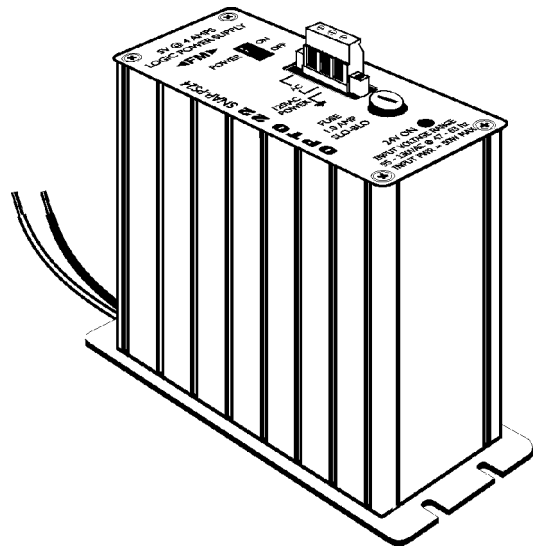

### Specifications

	SNAP-PS24	SNAP-PS24U
Input Voltage	95 to 130 Volts AC, 47-63 Hz	100–250 Volts AC, 47-63 Hz
Output Voltage	24 ± 0.6 Volts DC	24 ± 0.1 Volts DC
Output Current	0.75 Amps	1.25 Amps
Dimensions	See drawings on pages 5-6.	See drawing on page 7.
Weight	2.1 Pounds	1.9 Pounds (863.63 grams)
Temperature Operating Storage	0° C to 70° C -30° C to 85° C	0° C to 70° C -30° C to 85° C
Fuse Opto 22 P/N Vendor P/N	SNAP-FUSE1AB GDC-1A (Bussman)	Internal fuse

### Features

- Built-in fuse
- Brown-out protection
- ON/OFF power switch
- Wide input voltage range
- Optional DIN-rail mounting
- Convenient panel mounting
- Easy connection to line power
- Powers any combination of SNAP analog modules.
- Factory Mutual approved

### Installation

#### MOUNTING AND WIRING

1. Mount the SNAP-PS24 or SNAP-PS24U power supply in a location where the attached output power wires will reach the field connector for SNAP analog modules or the terminal strip on SNAP mounting racks that have the additional field wiring terminal strips.
2. The white and red wire is the positive wire (24 VDC). The white and black wire is the negative wire (24 VDC return). For specific loop power wiring information,

please refer to Opto 22 form number 784 for SNAP racks that have the additional field wiring terminal strip (Figure 1), or refer to form numbers 1065 and 1066 if wiring directly to the field connectors on SNAP analog modules (Figure 2). See the next page for SNAP-PS24U wiring diagrams.

3. Using the removable input power connector on top of the power supply, apply 120 volts of AC power between the two terminals marked "AC." The ground terminal should be connected to ground.

FIGURE 1 - SNAP-PS24

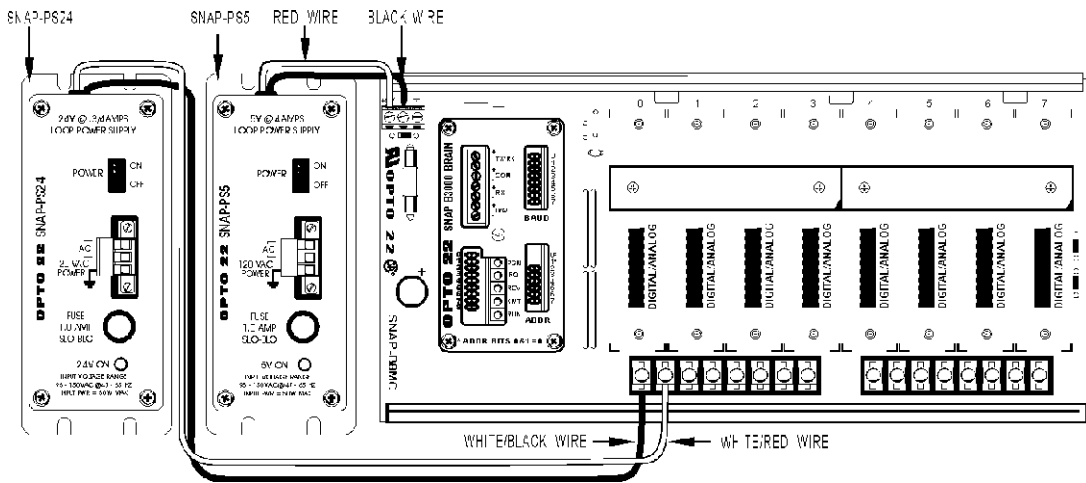
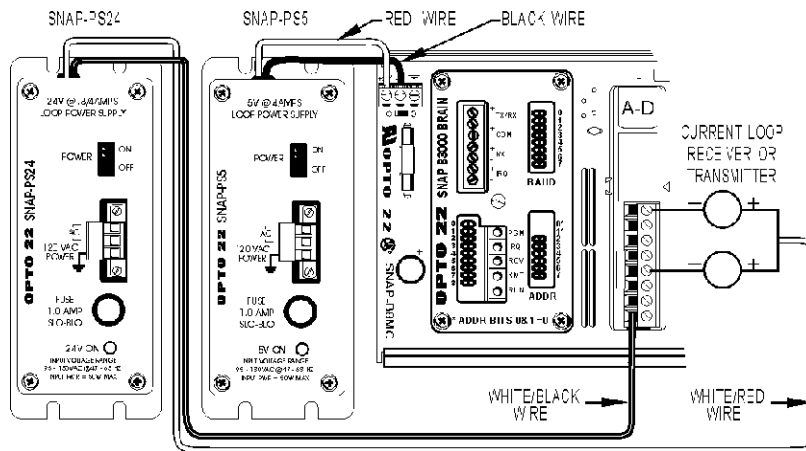

FIGURE 2-SNAP-PS24



# OPTO 22

## DATA SHEET

# SNAP POWER SUPPLY

page 3/7

Form 953-030801

### Installation—Mounting and Wiring (continued)

**FIGURE 1 - SNAP-PS24U**

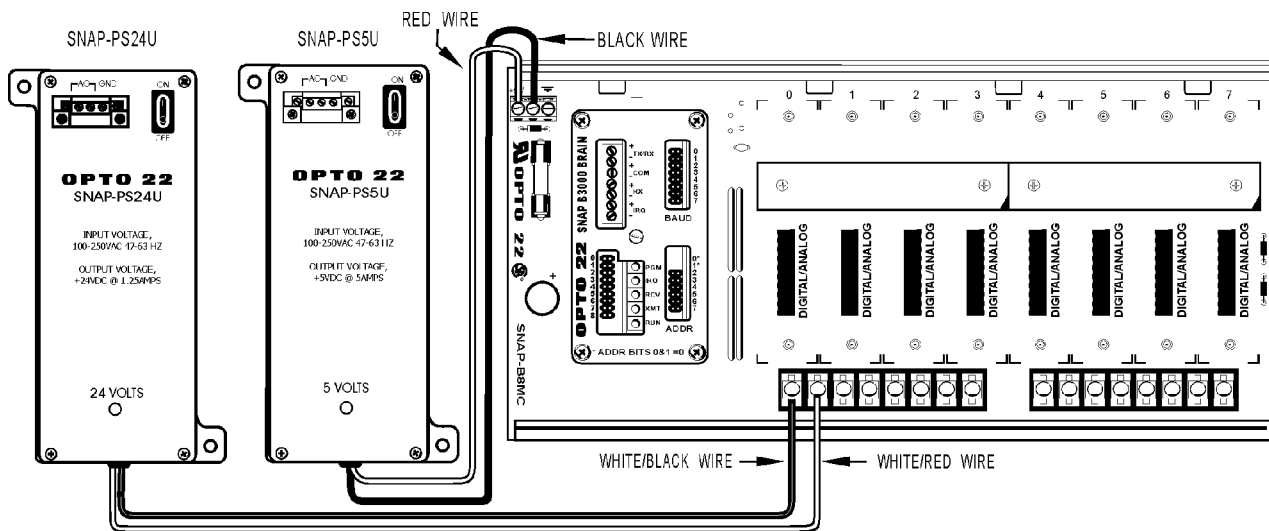

**FIGURE 2 - SNAP-PS24U**

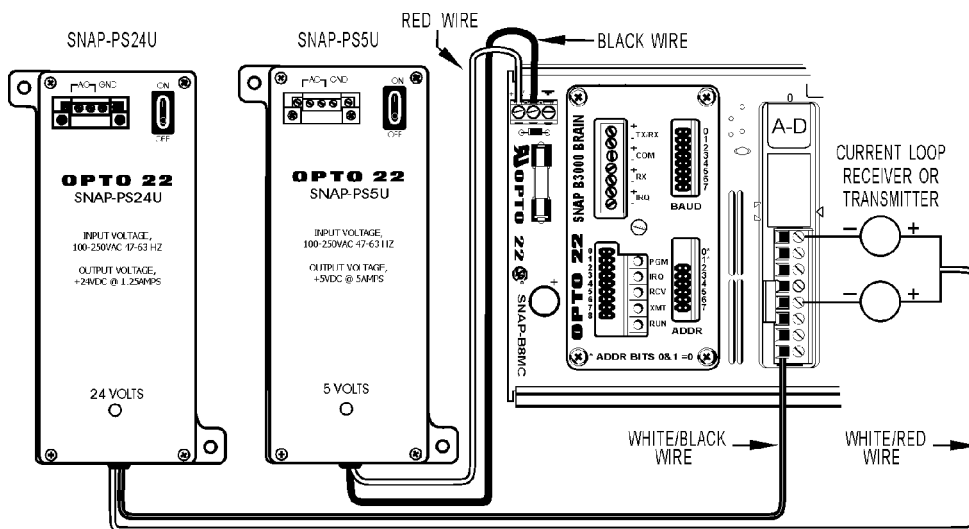

Form 953-030801

### Installation

#### DIN-RAIL MOUNTING (OPTIONAL)

1. For DIN-rail mounting, remove the four screws that fasten the panel mounting base plate to the power supply **(Save screws.)** Remove panel mounting base plate.
2. In place of the panel mounting base plate, use the four screws removed in step 1 to fasten the DIN-rail adapter to the power supply.
3. Mount the SNAP-PS24 or SNAP-PS24U on the DIN rail as close as possible to the rack and brain board assembly. The SNAP-PS24 is shown below as an example.

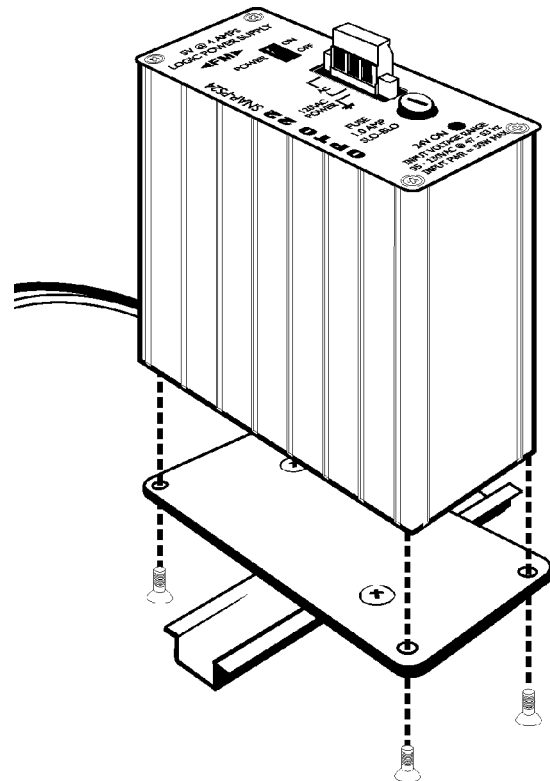
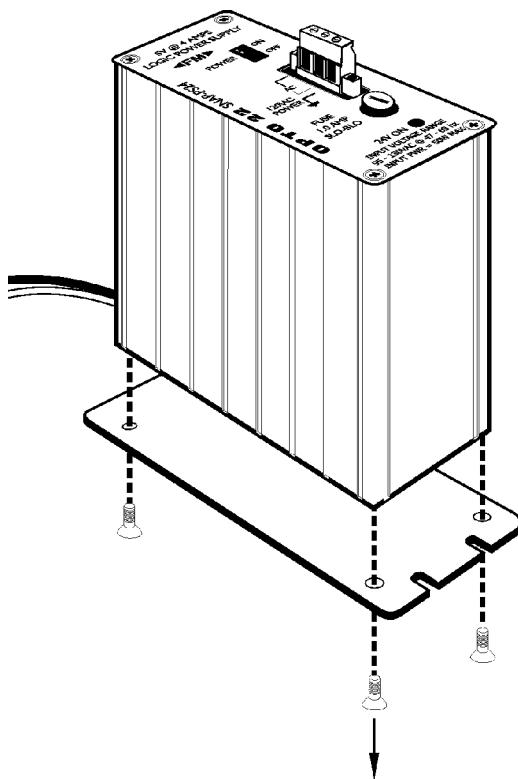

**DIN-RAIL ADAPTER ASSEMBLY (OPTIONAL)**

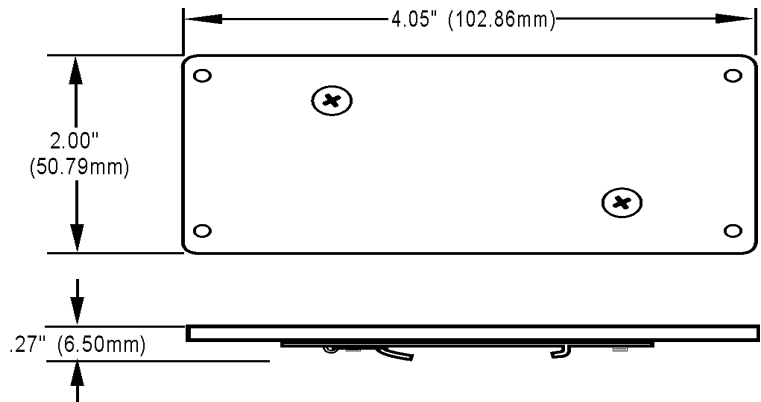

### Dimensions SNAP-PS24 POWER SUPPLY - PANEL MOUNT

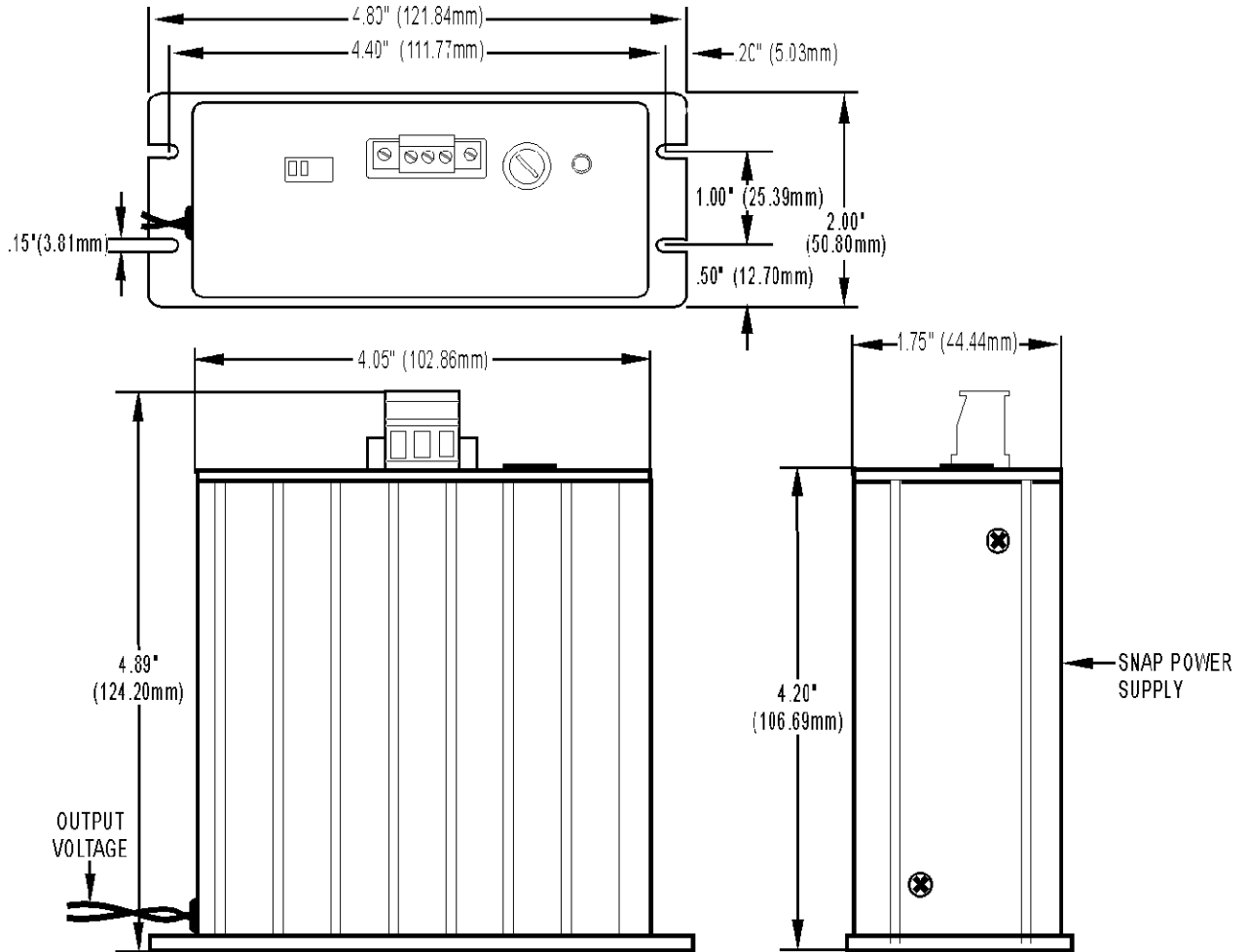

### Dimensions

### SNAP-PS24 POWER SUPPLY WITH DIN-RAIL ADAPTER

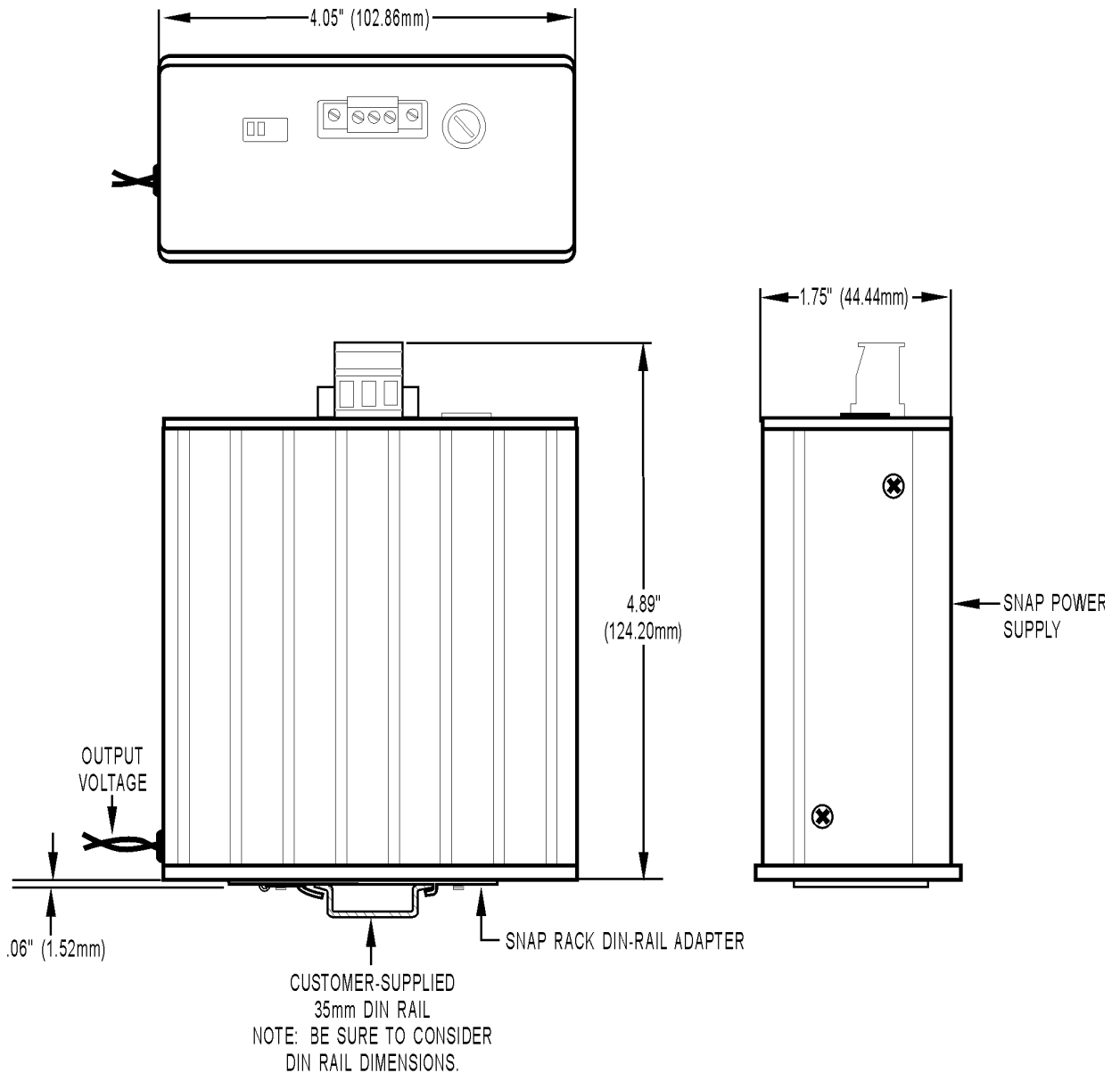

## DATA SHEET

Form 953-030801

### Dimensions

### SNAP-PS24U POWER SUPPLY - PANEL MOUNT

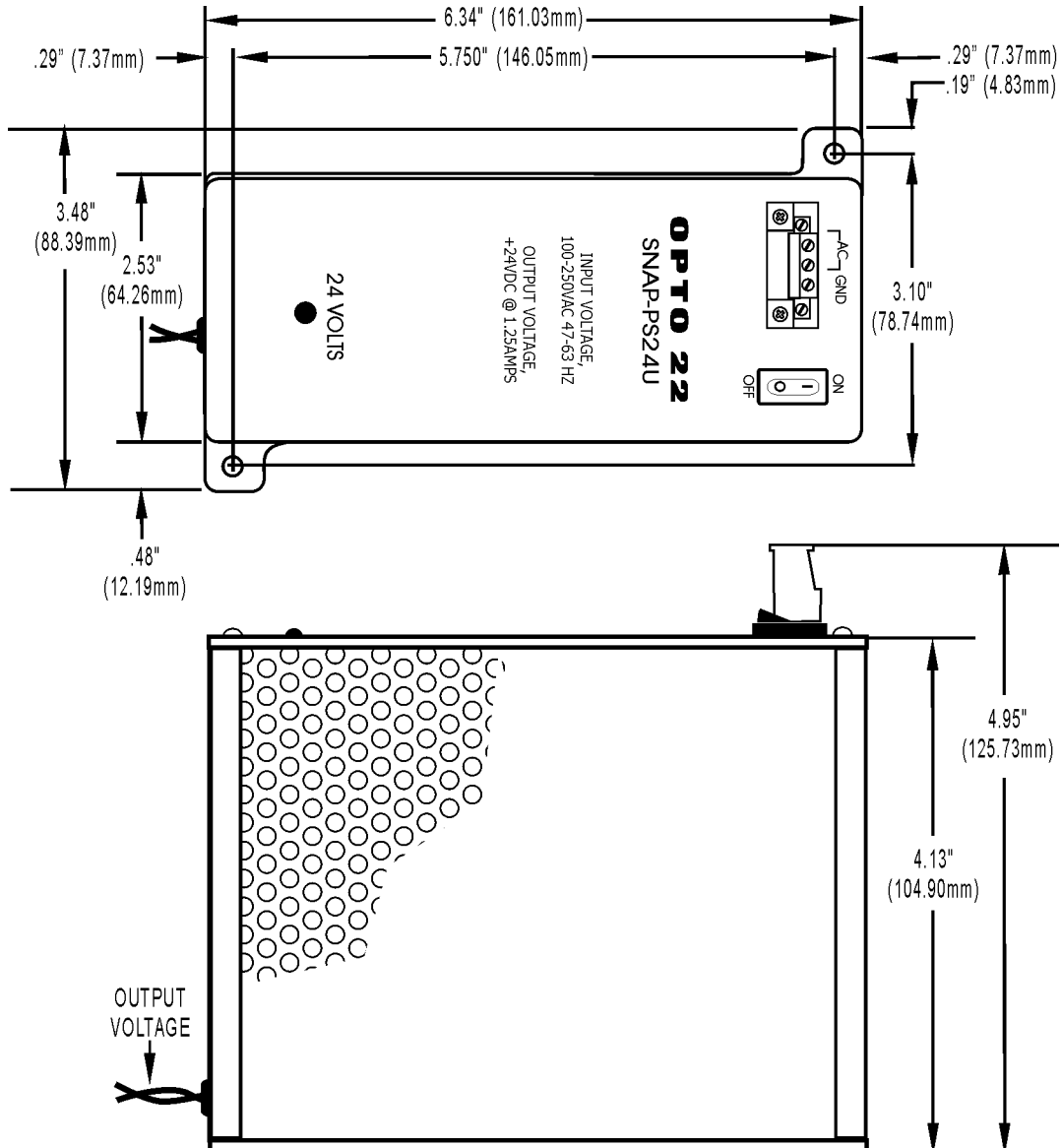

## Products

Opto 22 produces a broad array of reliable, flexible hardware and software products for industrial automation, remote monitoring, enterprise data acquisition, and machine-to-machine (M2M) applications.

### SNAP Ethernet Systems

Based on the Internet Protocol (IP), SNAP Ethernet systems offer flexibility in their network connectivity and in the software applications they work with. The physical network may be a wired Ethernet network, a cellular wireless network, or a modem. A wide variety of software applications can exchange data with SNAP Ethernet systems, including:

- Opto 22's own ioProject™ suite of control and HMI software
- Manufacturing resource planning (MRP), enterprise management, and other enterprise systems
- Human-machine interfaces (HMIs)
- Databases
- Email systems
- OPC client software
- Custom applications
- Modbus/TCP software and hardware.



SNAP Ethernet system hardware consists of controllers and I/O units. Controllers provide central control and data distribution. I/O units provide local connection to sensors and equipment.

### SNAP OEM Systems

Opto 22 SNAP OEM I/O systems are highly configurable, programmable processors intended for OEMs, IT professionals, and others who need to use custom software with Opto 22 SNAP I/O modules.

Linux® applications running on these systems can read and write to analog, simple digital, and serial I/O points on SNAP I/O modules using easily implemented file-based operations. Applications can be developed using several common development tools and environments, including C or C++, Java, and shell scripts.



### M2M Systems

Machine-to-machine (M2M) systems connect your business computer systems to the machines, devices, and environments you want to monitor, control, or collect data from. M2M systems often use wireless cellular communications to link remote facilities to central systems over the Internet, or to provide monitoring and control capability via a cellular phone.

Opto 22's Nvio™ systems include everything you need for M2M—interface and communications hardware, data service plan, and Web portal—in one easy-to-use package. Visit [nvio.opto22.com](http://nvio.opto22.com) for more information.

### Opto 22 Software

Opto 22's ioProject and FactoryFloor® software suites provide full-featured and cost-effective control, HMI, and OPC software to power your Opto 22 hardware. These software applications help you develop control automation solutions, build easy-to-use operator interfaces, and expand your manufacturing systems' connectivity.



### Quality

In delivering hardware and software solutions for worldwide device management and control, Opto 22 retains the highest commitment to quality. We do no statistical testing; each product is made in the U.S.A. and is tested twice before leaving our 160,000 square-foot manufacturing facility in Temecula, California. That's why we can guarantee solid-state relays and optically-isolated I/O modules *for life*.

### Product Support

Opto 22's Product Support Group offers comprehensive technical support for Opto 22 products. The staff of support engineers represents years of training and experience, and can assist with a variety of project implementation questions. Product support is available in English and Spanish from Monday through Friday, 7 a.m. to 5 p.m. PST.

### Opto 22 Web Sites

- [www.opto22.com](http://www.opto22.com)
- [nvio.opto22.com](http://nvio.opto22.com)
- [www.internetio.com](http://www.internetio.com) (live Internet I/O demo)

### Other Resources

- OptoInfo CDs
- Custom integration and development
- Hands-on customer training classes.



### About Opto 22

Opto 22 manufactures and develops hardware and software products for industrial automation, remote monitoring, enterprise data acquisition, and machine-to-machine (M2M) applications. Using standard, commercially available Internet, networking, and computer technologies, Opto 22's input/output and control systems allow customers to monitor, control, and acquire data from all of the mechanical, electrical, and electronic assets that are key to their business operations. Opto 22's products and services support automation end users, OEMs, and information technology and operations personnel.

Founded in 1974 and with over 85 million Opto 22-connected devices deployed worldwide, the company has an established reputation for quality and reliability.