

**RoHS  
Compliant**

## Description



The product is designed to hold PC boards during all stages of assembly, cleaning and testing. The width of the rack module is easily adjusted from 0 to 290mm by sliding one side panel along the aluminium extrusion and tightening 2 screws. One meter lengths of extrusion are available to allow construction of racks up to 970mm wide. The module is stackable in all directions so that racks of unlimited height and depth may be constructed.

The plastic sides are anti-static so that sensitive devices may be safely stacked in PCBs without special precautions other than earthing the rack.

The side panels are made from conductive plastic for use when highly sensitive integrated circuits need protection against anti-static charges throughout all handling, up to soak test or burn-in.

Maximum operating temperature is +85°C (Softening point +140°C). Volume resistivity 50Ω cm. Surface resistivity 10<sup>3</sup>Ω.

## Diagram

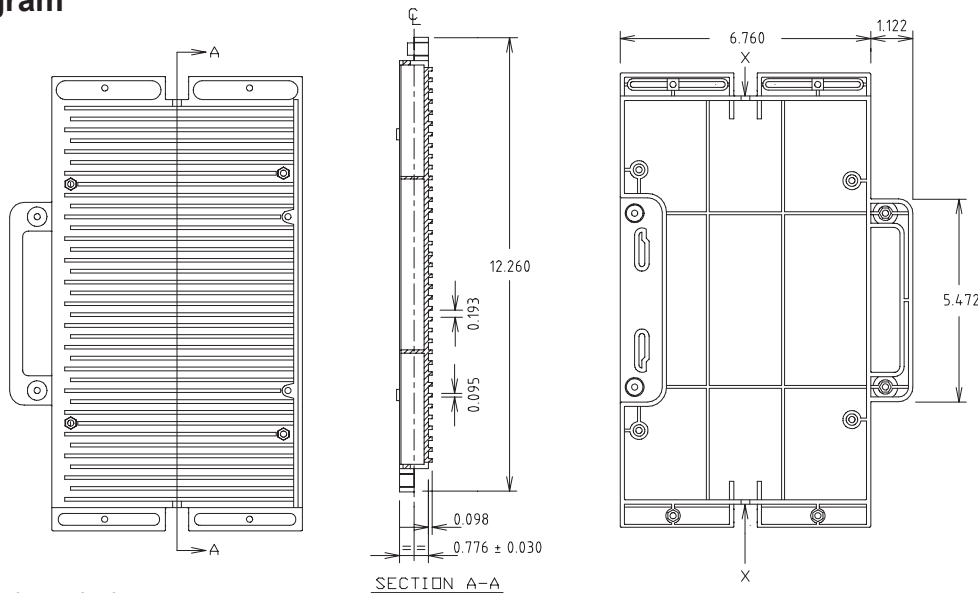

Dimensions : Inches

### Note:

'C' Version is Conductive

X-X R=<2.5kΩ

Surface Resistivity 10<sup>3</sup>Ω/sq

## Part Number Table

Description	Part Number
Modular PCB Rack	PC-01C

**Important Notice :** This data sheet and its contents (the "Information") belong to the members of the Premier Farnell group of companies (the "Group") or are licensed to it. No licence is granted for the use of it other than for information purposes in connection with the products to which it relates. No licence of any intellectual property rights is granted. The Information is subject to change without notice and replaces all data sheets previously supplied. The Information supplied is believed to be accurate but the Group assumes no responsibility for its accuracy or completeness, any error in or omission from it or for any use made of it. Users of this data sheet should check for themselves the Information and the suitability of the products for their purpose and not make any assumptions based on information included or omitted. Liability for loss or damage resulting from any reliance on the Information or use of it (including liability resulting from negligence or where the Group was aware of the possibility of such loss or damage arising) is excluded. This will not operate to limit or restrict the Group's liability for death or personal injury resulting from its negligence. Multicomp is the registered trademark of the Group. © Premier Farnell Limited 2016.