

RPF2AJD

power relay plug-in - Zelio RPF - 2 NO - 12 V DC - 30 A



Main

Range of product	Zelio Relay
Series name	Power
Product or component type	Plug-in relay
Device short name	RPF
Contacts type and composition	2 NO
Control circuit voltage	12 V DC
Control type	Without lockable test button
Shape of pin	Flat
Contacts material	Silver tin oxide
[I _{th}] conventional enclosed thermal current	25 A at -40...55 °C for relays side by side without a gap 30 A at -40...55 °C for 13 mm gap between two relays
Load current	25 A at 28 V DC 30 A at 250 V AC
Utilisation coefficient	10 %

Complementary

Mounting support	DIN rail Panel
Control circuit voltage limits	9.6...13.2 V
[I _e] rated operational current	30 A at 250 V AC (for NO) conforming to IEC 30 A at 277 V AC (for NO) conforming to UL 20 A at 28 V DC (for NO) conforming to UL 25 A at 28 V DC (for NO) conforming to IEC
[U _i] rated insulation voltage	250 V conforming to IEC 300 V conforming to UL
[U _{imp}] rated impulse withstand voltage	4 kV 1.2/50 μs
Maximum switching voltage	250 V conforming to IEC
Maximum switching capacity	7500 VA/700 W
Minimum switching capacity	6000 mW (500 mA / 12 V) for NO
Operating rate	<= 18000 cycles/hour no-load <= 1200 cycles/hour under load
Mechanical durability	5000000 cycles
Electrical durability	100000 cycles for resistive load
Average consumption	1.7 W
Drop-out voltage threshold	>= 0.1 U _c
Operating time	25 ms
Reset time	25 ms
Average resistance	86 Ohm (tolerance +/- 10 %) at 20 °C
Safety reliability data	B10d = 100000
Protection category	RT II
Operating position	Any position
Product weight	0.082 kg
Device presentation	Complete product

Environment

dielectric strength	2000 V AC between poles with basic insulation
---------------------	---

The information provided in this documentation contains general descriptions and/or technical characteristics of the products contained herein. This documentation is not intended as a substitute for and is not to be used for determining suitability or reliability of these products for specific user applications. It is the duty of any such user or integrator to perform the appropriate and complete risk analysis, evaluation and testing of the products with respect to the relevant specific application or use thereof. Neither Schneider Electric Industries SAS nor any of its affiliates or subsidiaries shall be responsible or liable for misuse of the information contained herein.

1500 V AC between contacts with micro disconnection insulation
4000 V AC between coil and contact with reinforced insulation

standards	EN/IEC 61810-1 UL 508 CSA C22.2 No 14
product certifications	CE CSA GOST UL
ambient air temperature for storage	-40...85 °C
ambient air temperature for operation	-40...55 °C
vibration resistance	3 gn (+/- 1 mm, f = 10...150 Hz) 5 cycles in operation 10 gn (+/- 1 mm, f = 10...150 Hz) 5 cycles not operating
IP degree of protection	IP40 conforming to EN/IEC 60529
shock resistance	10 gn in operation 30 gn not operating
pollution degree	3

Offer Sustainability

Sustainable offer status	Green Premium product
RoHS (date code: YYWW)	Compliant - since 0801 - Schneider Electric declaration of conformity
REACH	Reference not containing SVHC above the threshold
Product environmental profile	Available
Product end of life instructions	Need no specific recycling operations

Contractual warranty

Warranty period	18 months
-----------------	-----------

Dimensions

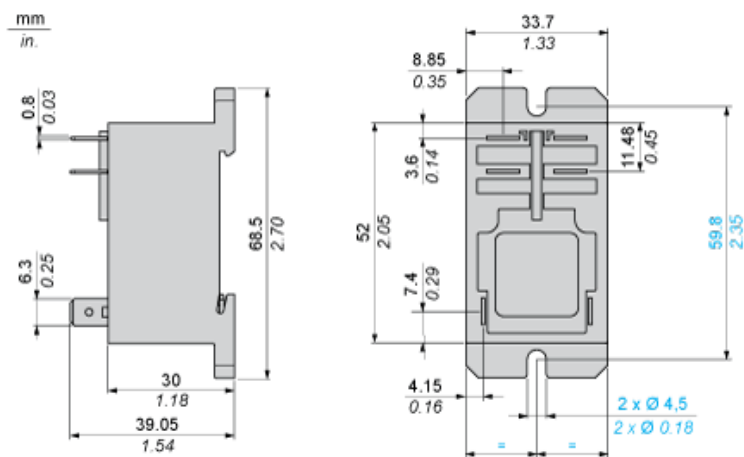

Wiring Diagram

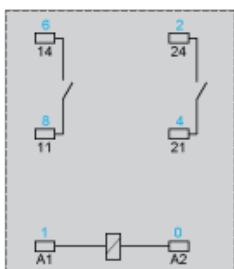

Symbols shown in blue correspond to Nema marking.

Electrical Durability of Contacts

AC Resistive load

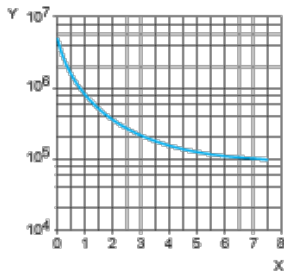

X Switching capacity (kVA)

Y Durability (number of operating cycles)

AC Reduction coefficient for inductive load (depending on power factor $\cos \phi$)

Durability (inductive load) = durability (resistive load) x reduction coefficient.

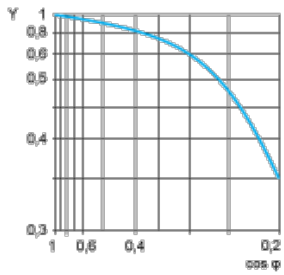

Y reduction coefficient

Maximum switching capacity on DC resistive load

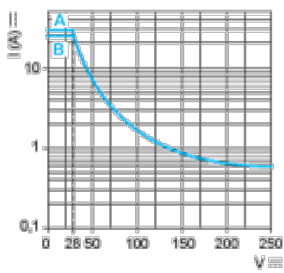

A 30 A

B 25 A

Note : These are typical curves, actual durability depends on load, environment, duty cycle, etc.